

Products By Category

AUTOMATIC CHARGE RELAYS	24-25
BATTERY BOXES	118
BATTERY SWITCHES	12-17
BUSBARS	106-110
CIRCUIT BREAKERS	
AC Rocker Single Pole	33, 43, 64, 73
AC Rocker Double Pole	64, 73
AC Toggle Single Pole	63, 72
AC Toggle Double Pole	63, 65, 72
AC Toggle Triple Pole	65, 74
DC Rocker Single Pole	33, 43, 64, 73
DC Rocker Double Pole	33, 64, 73
DC Thermal	30-31, 40
DC Toggle Single Pole	32, 41, 63, 72
DC Toggle Double Pole	32, 63, 72
DC Toggle Triple Pole	32, 65, 74
Push Button	40
CONNECTORS	
BusBars	106-110
Feed Through Terminals	114
PowerPosts	115
Terminal Blocks	111-113
FUSE BLOCKS	
Fuse Blocks	34-37, 56-58
FUSES	
Fuses	34-37, 58-59
INSULATORS	
CableCaps	117
CableClams	116
METERS	
Accessories	102-103
AC Analog	100
AC Digital	96-97
DC Analog	101-102
DC Digital	98-99, 102
Digital Dimmer	104
PANELS	
AC 240 Volt	77
AC Main	76-81
AC Main Only	57, 66, 76-77, 80-81
AC Rocker	76
AC Source Selector	67-70, 77-79
AC Toggle	77-85
Accessories	86-94
DC Battery Management	18-21
DC Rocker	45
DC Toggle	46-47
Labels	89-94
Water Resistant Circuit Breaker	48-49, 52
Water Resistant Fuse	50-51, 53
SWITCHES	
Battery	12-17
Solenoid	22-26
Panel	86
Water Resistant Contura	55
WeatherDeck™ Toggle	54

Products By Application

ENGINEERING INFORMATION AND TECHNICAL SUPPORT	2
UPDATED PRODUCTS SHOWCASE	3
NEW PRODUCTS SHOWCASE	4-5
DC MAIN POWER DISTRIBUTION AND CIRCUIT PROTECTION	6-37
DC Main Power Distribution - Introduction	6-8
DC Battery Switch - Introduction	9-11
DC Mini Battery Switches	12-13
DC High Performance Battery Switches	14-17
DC Battery Management Panels	18-21
DC Solenoid Switches	22-26
DC Main Circuit Protection - Introduction	27-29
DC Thermal Circuit Breakers	30-31
DC Magnetic Circuit Breakers and Accessories	32-33
DC Fuse Blocks and Fuses	34-37
DC BRANCH POWER DISTRIBUTION AND CIRCUIT PROTECTION	38-59
DC Branch Power Distribution and Circuit Protection - Introduction	38-39
DC Thermal Circuit Breakers and Accessories	40
AC/DC Magnetic Circuit Breakers	41,43
Magnetic Rocker Circuit Breaker - Introduction	42
DC Panel Features	44
DC Rocker Circuit Breaker Panels	45
DC Toggle Circuit Breaker Panels	46-47
DC Water Resistant Panels	48-53
DC Water Resistant Panel Accessories	54-55
DC Fuse Blocks and Fuses	56-59
AC MAIN POWER DISTRIBUTION AND CIRCUIT PROTECTION	60-70
AC Main Power System - Introduction	60-62
AC/DC Magnetic Circuit Breakers	63-64
AC Magnetic Circuit Breakers and Accessories	65
AC Main Only Circuit Breaker Panels	66
AC Source Selection Circuit Breaker Panels	67
AC Rotary Switches and Source Selection Panels	68-70
AC BRANCH POWER DISTRIBUTION AND CIRCUIT PROTECTION	71-85
AC Branch Power Systems - Introduction	71
AC/DC Magnetic Circuit Breakers	63-64
AC Magnetic Circuit Breakers	74
AC Panel Features	75
AC Rocker Circuit Breaker Panels	76
AC Toggle Circuit Breaker Panels	77-83
AC/DC Circuit Breaker Panels	84-85
PANEL ACCESSORIES	86-94
Panel Accessories	86-90
Large Format Panel Labels Listing	91-94
METERS AND ELECTRONIC CONTROLS	95-105
Digital Meter Features	95
AC Digital Meters	96-97
DC Digital Meters	98-99
AC Analog Meters	100
DC Analog Meters	101
Meter Accessories	102-103
DC Digital Dimmers	104
DC Digital Dimmer Control Switches	105
CONNECTORS	106-115
BusBars	106-110
Terminal Blocks	111-113
Feed Through Terminals	114
PowerPosts	115
INSULATION AND SAFETY	116-118
Cable Clams	116
CableCaps	117
Battery Boxes	118
APPENDIX	119-128
Technical Glossary	119-125
Index By Part Number	126-128
Products By Category	Back Cover

Blue Sea Systems Engineering

Blue Sea Systems designs quality, reliable, and innovative products for the marine industry. The company is comprised of avid boaters with decades of experience in craft ranging from 16' runabouts to sailboats and have years of blue water sailing experience.

The company boat, a 36' express trawler, is used to test Blue Sea Systems products and ideas and improve the products offered. The engineering staff applies their previous experience designing test equipment, medical lasers, high amperage bus systems, circuit breakers, and marine systems to the Blue Sea Systems products they design. This results in the delivery of innovative, reliable products for the marine industry that exceed the quality standards of other companies. Blue Sea Systems in house lab is used to load test and thermal test products to ensure they will perform under marine conditions.



Indigo - Blue Sea Systems Boat



Thermal Testing

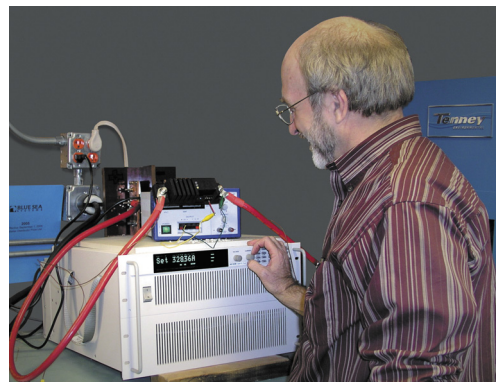

Load Testing

Technical Support

The Blue Sea Systems support team and engineers are available to answer questions about products and their applications. Application and technical information is available online at www.blueseasystems.com including product instructions. Access to Blue Sea Systems technical staff, combined with the website, ensure industry leading support for your needs.

Look For Blue Sea Systems Copper Icon (your assurance of genuine copper construction)

Tin-Plated Copper is 250% More Conductive Than Brass

Blue Sea Systems uses tin-plated pure electrical copper where appropriate, rather than the lower cost brass alloys used by some manufacturers. Just as electrical wire is always copper, so are the Blue Sea Systems products to which this wire is attached made with pure CDA 11000 Electrical Grade Copper.

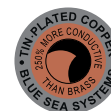

Copper is 250% more conductive than brass. Electrical devices made with copper are capable of handling higher amperages at lower temperatures. Blue Sea Systems tin-plating adds additional performance by protecting the copper from corrosion that can produce poor conductivity at connection points.

Plated brass can look just like tin-plated copper; Blue Sea Systems tin-plated copper icon assures that the product to which it is attached is made of pure electrical grade copper.

Parallel Circuit Mini Switch Battery Management Panels

Now includes the NEW M-Series Battery Switches with ONE PIECE studs that eliminate the need for a securing nut and provide easy access to battery cables

▷ See pages 18-19

Updated Version Available January, 2006



8080

8280

8370

2301 Busbar

Optional snap on insulating cover that attaches to studs, pressed-on busbar that eliminates the need for a securing nut, and unobstructed wire access

▷ See pages 106, 108

Updated Version Available January, 2006



2301 (cover not included)

ANL Light Fuse Block

Now includes a NEW snap on insulating cover that attaches to studs, NEW swing out design that allows replacement of fuse without removing fasteners, and unobstructed wire access

▷ See page 35

Updated Version Available January, 2006



5005

Sea Fuse Block

Now includes a NEW snap on insulating cover that attaches to studs and unobstructed wire access

▷ See page 34

Updated Version Available January, 2006



5001

Look For **UPDATED PRODUCT** Throughout

M-Series Battery Switches (Mini)

Redesigned popular Mini Battery Switch with ONE PIECE studs, new front panel mounting option, and three new switch configurations

- Case design allows front panel, rear panel and surface mounting
- Removable knob or key remains positively retained at all times
- Ideal for marine or RV applications

▷ See pages 12-13

Note: 6005 replaces 9005
6006 replaces 9006

Available January, 2006



6005
Single Circuit
ON/OFF



6006
Single Circuit
ON/OFF



6007
Selector



6011
Dual Circuit Plus™



6010
Dual Circuit

E-Series Battery Switches

New DUAL CIRCUIT PLUS™ simplifies switch operation and reduces the risk of a dead Start battery

- Keeps House and Start battery banks isolated while there is current flow from both battery banks
- The BOTH function offers the ability to combine two battery banks in the event of a low Start battery
- Luminous label for low light reading

▷ See pages 14-15

Available January, 2006



5511E
Dual Circuit Plus™



5510E
Dual Circuit

HD-Series Battery Switch (Heavy Duty)

New Heavy Duty SELECTOR Battery Switch

- Up to 600 Ampere Continuous Rating for large diesel engines, high power output, and low heat generation
- M12 (1/2") Tin-plated copper studs for maximum conductivity and corrosion resistance
- Luminous label for low light reading

▷ See pages 16-17

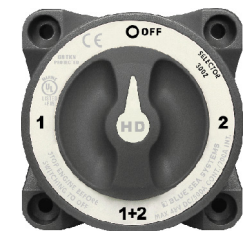

3002-3003
Selector

L-Series Solenoid Switches

New 250 Ampere class, 12 or 24 Volt

- Ignition protected - Safe for installation aboard gasoline powered boats
- Functions as a remote battery switch
- Noise free circuitry will not interfere with other devices

▷ See page 22

Available January, 2006

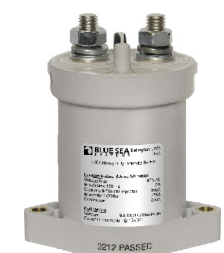

5301 - 12 Volt
5302 - 24 Volt

WeatherDeck™ Water Resistant Circuit Breaker Panels

New WeatherDeck™ Circuit Breaker Panels designed for flybridge and open cockpit applications

- Easy to identify tripped circuit breakers
- Bi-colored LEDs illuminate circuit labels to quickly identify “OFF” or “ON”
- Each panel can be mounted in four different orientations

▷ See pages 48-49

Available January, 2006



4374



4376

Dual Battery Main Distribution Panels

For dual battery, single engine systems to manage all DC Main circuit demands including 24 hour circuits in one panel

- Provides main DC circuit protection in addition to high ampere loads
- Simplifies battery switch operation
- Discharges batteries independently

▷ See page 20

Available January, 2006



8686



8690

Triple Battery Main Distribution Panels

For triple battery, twin engine systems to manage all DC Main circuit demands including 24 hour circuits in one panel

- Provides 24 hour circuit protection
- Simplifies battery switch operation
- Discharges batteries independently

▷ See page 21

Available January, 2006



8689



8693

Rocker Circuit Breakers (Small Case 2” and Large Case 2.5”)

Two new modern FLAT actuator designs, including a version with a built-in reset SLOT

- Highly resistant to accidental switching
- International ON/OFF symbols for vertical or horizontal mounting
- Mounting aperture can accommodate breakers from 5A to 250A

▷ See pages 33, 42, 43, 73



7433 Small Case



7450 Large Case



7408 Small Case

Look For **NEW PRODUCT** Throughout

The DC Main Power Distribution System conducts power from the battery banks to the beginning of the DC Branch Distribution System. The four elements of the DC Main Power Distribution System are illustrated below:

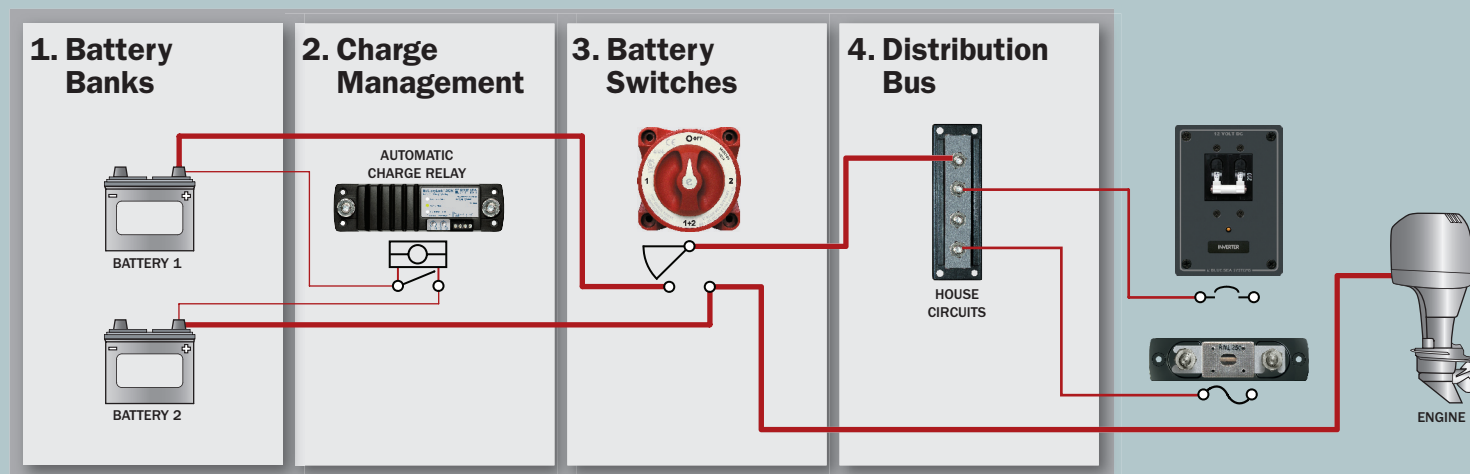

1. Battery Banks

Purpose

To store sufficient energy to power the ship's loads between charging cycles. Charging is typically provided by the alternator while under way and the battery charger when connected to shore power. Additionally, for boats with two battery banks, to provide a second source of energy storage isolated from the first, sufficient to start the engine and recharge all battery banks.

Considerations

Blue Sea Systems advises having a second battery bank for emergency engine starting while attempting to avoid having more than two. Some engine manufacturers recommend having a separate battery bank dedicated to each engine in addition to the House battery bank. Limiting the boat to two battery banks, however, will provide the greatest simplicity and reliability.

2. Charge Management

Purpose

In multiple battery bank systems, Charge Management Devices (CMD's) provide a means of combining two battery banks when charging, while keeping the battery banks isolated from each other when the charging source is not charging. This assures that even if one battery bank is depleted there will always be a charged battery bank available for engine starting. Some devices can also provide a means of connecting both battery banks together for additional power while starting engines. There are many types of CMD's that fulfill this role; the two main categories are Battery Isolators and Automatic Charge Relays (ACR's).

Considerations

Battery Isolators are a common method of distributing charging current to multiple battery banks while assuring that they remain electrically isolated during discharge. These devices are electrical "one way check valves" that allow current flow to, but not from, the battery. Their disadvantage is that the diodes used to achieve this cause a voltage drop that consumes charging energy, creates heat, and causes batteries to be undercharged. Alternators with external voltage sensing can correct for the undercharging problem, but voltage drop and the heat generated remain a problem.

Automatic Charge Relays (ACR's) are becoming the popular method for achieving the same goal as isolators, but they work on a different principle. Instead of using diodes to block current from flowing in both directions, ACR's use mechanical relays combined with a circuit that senses when a charging source is being applied to either battery. When a charge is being applied, the ACR closes; and when the circuit senses that the charge is no longer present, the ACR opens after a short time delay which assures that the ACR does not open during temporary voltage sags due to load start-ups. The most common method of determining that a charge is being applied to the system is to sense voltages in the region above 12.6 Volts DC.

Battery Isolator and Automatic Charging Relay Comparison

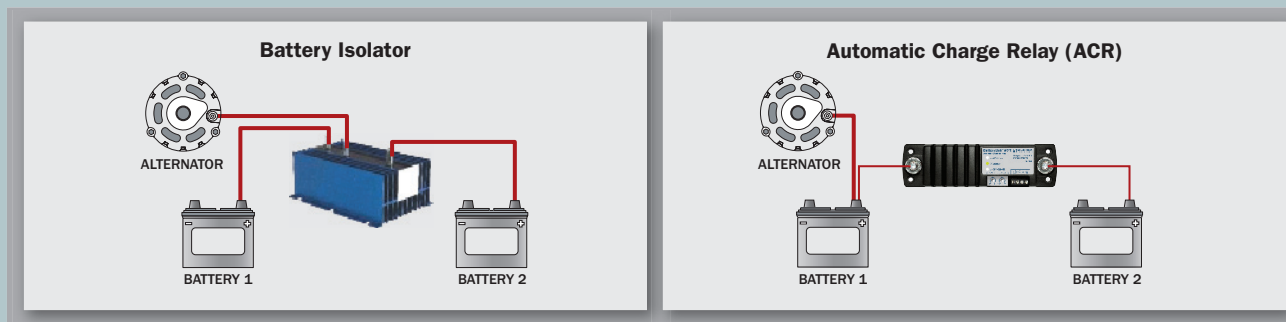

Automatic Charge Relay Operation

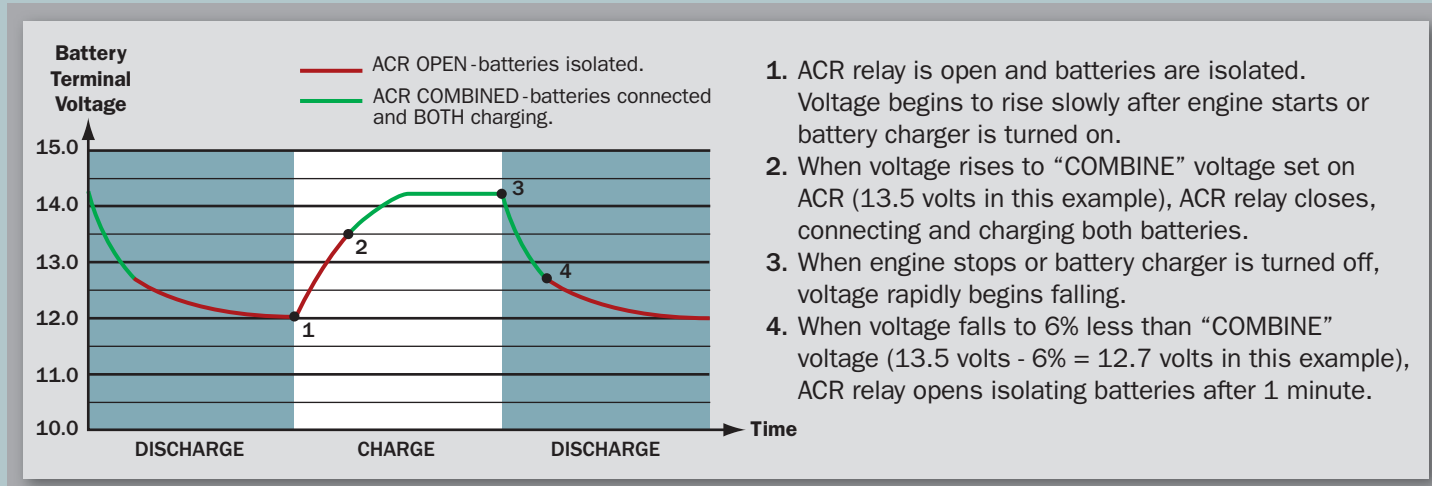

Considerations when selecting an Automatic Charge Relay:

- **Current Management**

Automatic Charge Relays (ACR's) can potentially be exposed to very high currents if the engine is cranked while the ACR is closed, paralleling the battery banks. This can occur when an alternate charge source causes the ACR to close. Blue Sea Systems uses two methods for dealing with this. Smaller ACR's such as the CL-Series BatteryLink™ ACR have automatic current management circuits, while larger ACR's like the L-Series ACR have high amperage contacts rated for engine starting.

- **Over Voltage Adjustability**

This allows the ACR to be used between different type battery banks in which one battery bank requires lower maximum charging voltages than the other battery bank.

- **Combining and Disconnecting Voltage Adjustability**

This allows the voltage at which the ACR closes and its associated cut-out voltage to be adjusted for the specific requirements of each boat's electrical system.

- **Manual Override**

This allows the ACR to be manually opened, set to automatic, or manually combined from a remote location.

3. Battery Switches

Purpose

To isolate the potentially destructive energy in the battery banks when the boat is not in use or in emergencies.

ABYC 11.7.1.2.1. A battery switch shall be installed in the positive conductor(s) from each battery or battery bank with a CCA rating greater than 800 Amperes.

Considerations

Historically there have been two types of battery switches used on boats; Single Circuit and Battery Selector Switches.

In 2006, Blue Sea Systems is introducing a third option called a DUAL CIRCUIT PLUS Battery Switch as a better alternative.

On page 9 are schematics for each type of switch and the advantages and disadvantages of each.

Selecting a Battery Switch

Any battery switch used in a marine application should be UL Listed to UL Standard 1107 or should be tested to this standard by a Nationally Recognized Testing Laboratory, of which UL is only one of many. In particular, any amperage rating other than those determined by UL 1107, or a standard whose details are publicly stated by the manufacturer, should be treated with skepticism.

Battery Switch Ratings

The UL standard for marine battery switches is UL Standard 1107. This standard rates switches only for 5 minute and 1 hour time periods. Clearly, these ratings are not useful for the boater using a switch in the engine starting circuit where current durations may be 10 seconds or less. For this reason, Blue Sea Systems has created an additional standard called the **Engine Starting Standard**. The **Engine Starting Standard** is 10 cycles, each consisting of an Inrush Current spike of 1/4 second duration, a Cranking period of 9-3/4 seconds duration, and a 2 second rest period for a total of 120 seconds. This is representative of the load imposed on a battery switch in the starting circuit under very difficult starting conditions. Blue Sea Systems battery switches, in addition to being tested to UL 1107, are also tested to the **Engine Starting Standard** by a United States Coast Guard certified Nationally Recognized Testing Laboratory.

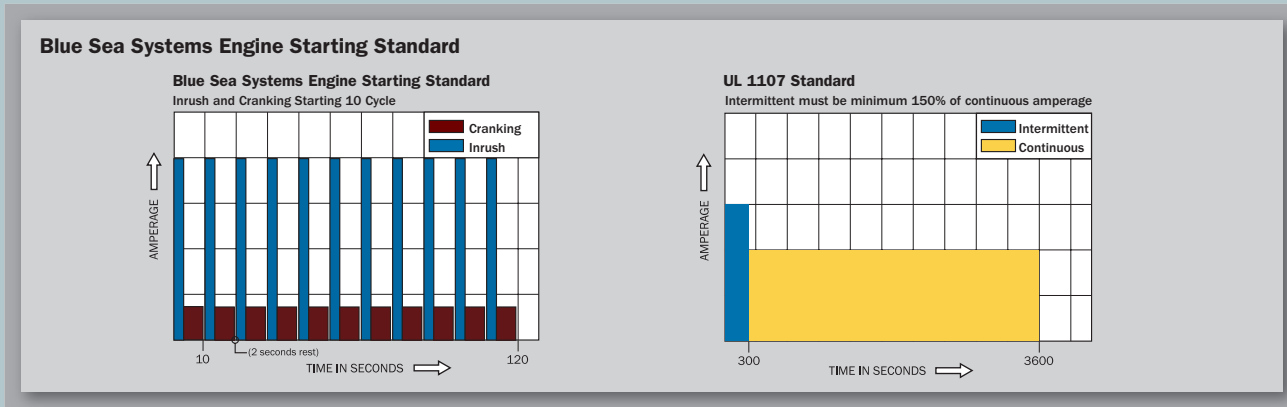

When determining the proper size battery switch, consult your engine manufacturer for the amperage requirements of your engine starter motor. If this information is not available from the engine manufacturer you may refer to the following rule of thumb used by mechanics to roughly estimate the cranking requirement of various type and sizes of engines.

Estimating starter motor amperage draw to determine size of battery switch

Gasoline engines - 1 amp/cubic inch of engine displacement = cranking rating
 Diesel engines - 2 amps/cubic inch of engine displacement = cranking rating

* These values are intended to be general estimates and do not apply to gear reduction starter motors. Ed, Sherman, *Power Boaters Guide to Electrical Systems*, 2000

ABYC Requirements

11.7.1.2.3. *Battery Switch Ratings – The intermittent rating of a battery switch shall not be less than the maximum cranking current of the largest engine cranking motor that it serves. The minimum continuous rating of a battery switch shall be the total of the ampacities of the main overcurrent protection devices connected to the battery switch, or the ampacity of the feeder cable to the switch, whichever is less.*

ABYC Standards for battery switches are currently under review by the ABYC Project Technical Committee for battery switches. The two major changes likely to be made are that allowable temperature rise will decrease, thereby lowering the amperage ratings that switches currently carry, and the Engine Starting Standard developed by Blue Sea Systems will be incorporated into the standard.

4. Distribution Bus

Purpose

On any but the smallest boats it is impractical to attach all of the wires from each load

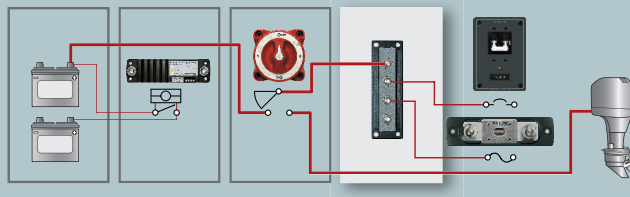

directly to the battery terminal or the battery switch terminal. For this reason, a positive distribution bus, (a solid bar of tin-plated electrical copper) is used to convert the large wire from the batteries to the smaller wires that carry current out to the each load device. Large boats may have many layers of progressively smaller busbars, while small boats may have only a small busbar attached to the back of the electrical distribution panel.

Considerations

When selecting a distribution bus, Blue Sea Systems suggests it have the following qualities:

1. Solid copper construction for low voltage drop and low heat rise.
2. Stainless steel terminals for strength and corrosion resistance. In a distribution bus, the terminal is a compressive element, not a conductive element. Its purpose is to press the ring terminal against the busbar. This is different from a battery switch in which the terminal's job is to carry current through the terminal and into the interior of the switch.
3. Tin plating to resist corrosion and maintain low resistance connections.
4. Continuous rating equal to or greater than the maximum continuous amperage of the system in which it will be installed.

New DUAL CIRCUIT PLUS™ Battery Switch for 2006!

Dual Circuit switching technology offers the advantages of MULTIPLE Single Circuit ON/OFF switches in ONE switch

Switch Set to "ON"

Batteries isolated - Current flow from both House and Start batteries

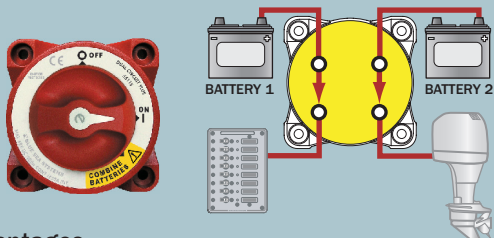

Switch Set to "COMBINE BATTERIES" ⚠ SEE BELOW

Batteries combined - Current flow from both House and Start batteries

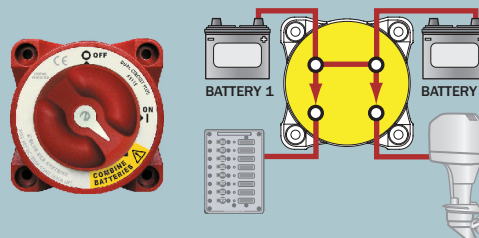

Advantages

- 1) Simple ON/OFF switching in NORMAL operation (with an ACR or isolator installed)
- 2) Isolates Start and House circuits reducing the chance of fully discharging both batteries
- 3) Isolates Start and House circuits protecting electronics from engine starting sags and spikes

Compare with the alternatives

SELECTOR Battery Switch



Switch Set to "1"

Current flow from Battery 1 to both House and Start circuits

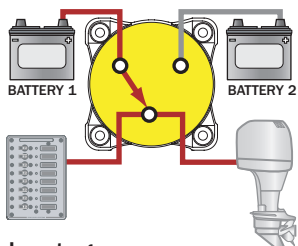

Switch Set to "2"

Current flow from Battery 2 to both House and Start circuits

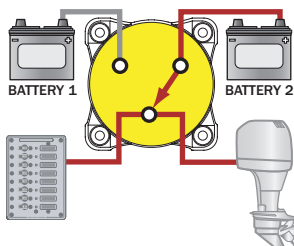

Switch Set to "1+2" ⚠ SEE BELOW

Batteries combined - Current flow from both House and Start batteries

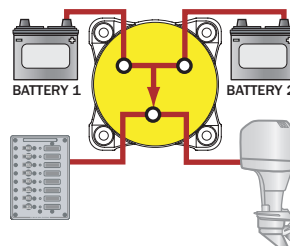

Disadvantages

- 1) Not intuitive to operate
- 2) When the switch is left in "1+2" position all batteries can be discharged
- 3) The Engine circuit and House circuit are combined exposing electronics to sags and spikes caused by engine starting

Multiple SINGLE CIRCUIT ON/OFF Battery Switches



Battery 1 Switch Set to "ON" Battery 2 Switch Set to "ON"

Current flow from Battery 1 to House circuit and Battery 2 to Start circuit

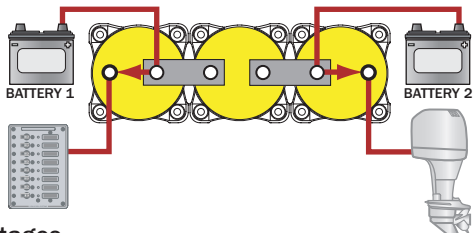

Battery 1 Switch Set to "ON" ⚠ SEE BELOW Battery 2 Switch Set to "ON"

Emergency Parallel Battery Switch Set to "ON"
Batteries combined - Current flow from both House and Start batteries

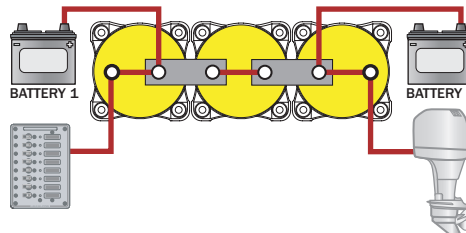

Disadvantages

- 1) Most expensive option
- 2) Requires more space
- 3) Not intuitive to operate- user must operate 3 switches
- 4) Wiring and switch interconnection complexity





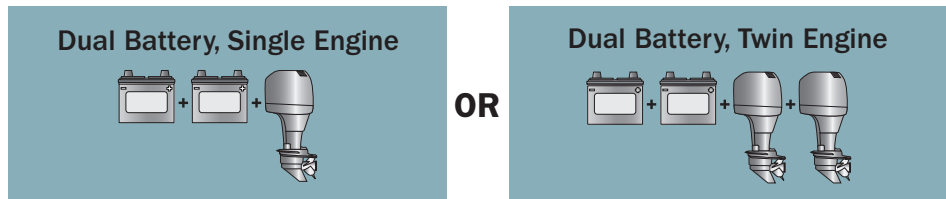

⚠ NORMAL OPERATION - Batteries combined for charging when no Automatic Charging Relay or Isolator is installed
EMERGENCY OPERATION - Batteries combined when Start battery is low

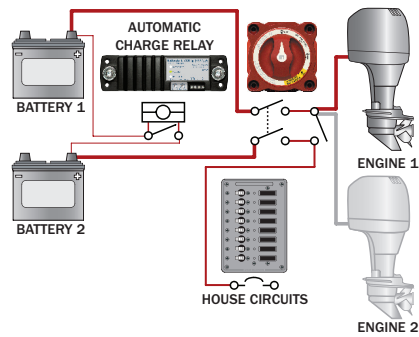
Products to consider for common electrical system configurations with various motor and battery bank combinations.









DUAL CIRCUIT PLUS™ Battery Switch

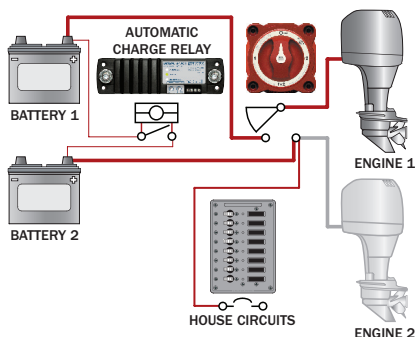

Products To Consider					
Product	Outboard Engine*	Small Inboard Gasoline or Diesel*	Small Inboard Gasoline or Diesel*	Large Inboard Gasoline or Diesel*	Large Inboard Gasoline or Diesel*
Automatic Charge Relay	7600 pages 24, 26 	7600 pages 24, 26 		9112 pages 25-26 	
DUAL CIRCUIT PLUS Battery Switch	6011 pages 12-13 	5511c pages 14-15 		5511c pages 14-15 	







SELECTOR Battery Switch

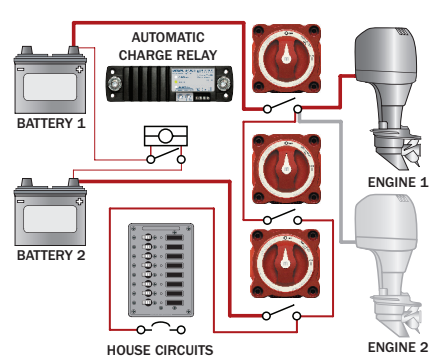

Products To Consider					
Product	Outboard Engine*	Small Inboard Gasoline or Diesel*	Small Inboard Gasoline or Diesel*	Large Inboard Gasoline or Diesel*	Large Inboard Gasoline or Diesel*
Automatic Charge Relay	7600 pages 24, 26 	7600 pages 24, 26 		9112 pages 25-26 	
SELECTOR Battery Switch	6007 pages 12-13 	9001c pages 14-15 		3002 pages 16-17 	

Multiple SINGLE CIRCUIT ON/OFF Battery Switches



Products To Consider					
Product	Outboard Engine*	Small Inboard Gasoline or Diesel*	Small Inboard Gasoline or Diesel*	Large Inboard Gasoline or Diesel*	Large Inboard Gasoline or Diesel*
Automatic Charge Relay	7600 pages 24, 26 	7600 pages 24, 26 		9112 pages 25-26 	
SINGLE CIRCUIT ON/OFF Battery Switch	6006 pages 12-13 	9003c pages 14-15 		3000 pages 16-17 	





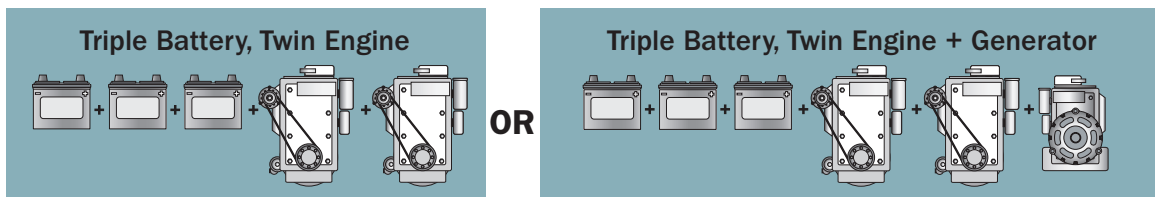

*Engine sizes are suggested only as general categories and are not intended to represent the variety of engine sizes. Please go to the product pages in this catalog for the detailed specifications of each product.

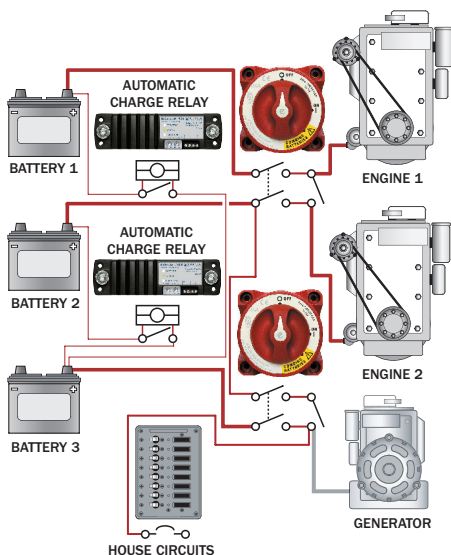
Products to consider for common electrical system configurations with various motor and battery bank combinations.



DUAL CIRCUIT PLUS™ Battery Switch and SINGLE CIRCUIT ON/OFF Battery Switch







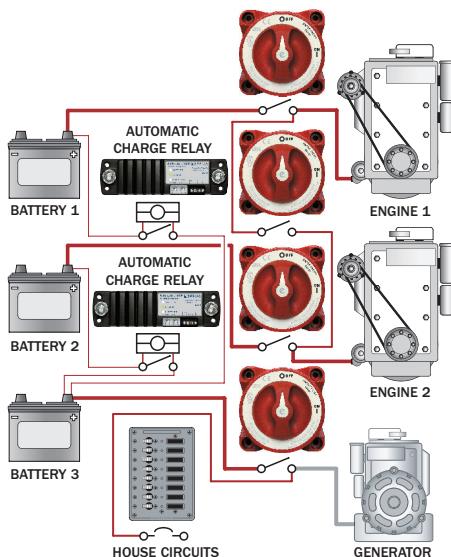

Products To Consider					
Product	Outboard Engine*	Small Inboard Gasoline or Diesel*	Large Inboard Gasoline or Diesel*		
Automatic Charge Relay	7600 pages 24, 26 	7600 pages 24, 26 	9112 pages 25-26 		
DUAL CIRCUIT PLUS Battery Switch	6011 pages 12-13 	5511C pages 14-15 	5511C pages 14-15 		

SELECTOR Battery Switch

The use of multiple SELECTOR Battery Switches is highly discouraged. Since the large number of possible switch settings is extremely confusing to the boat operator, and the possibility of operator error is very high. Two SELECTOR Battery Switches offer the operator 16 different combinations of settings.

Multiple SINGLE CIRCUIT ON/OFF Battery Switches



Products To Consider					
Product	Outboard Engine*	Small Inboard Gasoline or Diesel*	Large Inboard Gasoline or Diesel*		
Automatic Charge Relay	7600 pages 24, 26 	7600 pages 24, 26 	9112 pages 25-26 		
SINGLE CIRCUIT ON/OFF Battery Switch	6006 pages 12-13 	9003C pages 14-15 	3000 pages 16-17 		

*Engine sizes are suggested only as general categories and are not intended to represent the variety of engine sizes. Please go to the product pages in this catalog for the detailed specifications of each product.

Available January, 2006

M-Series Battery Switches (Mini) **NEW PRODUCT**

300 Amperes Continuous Rating for outboards and small inboard gasoline engines

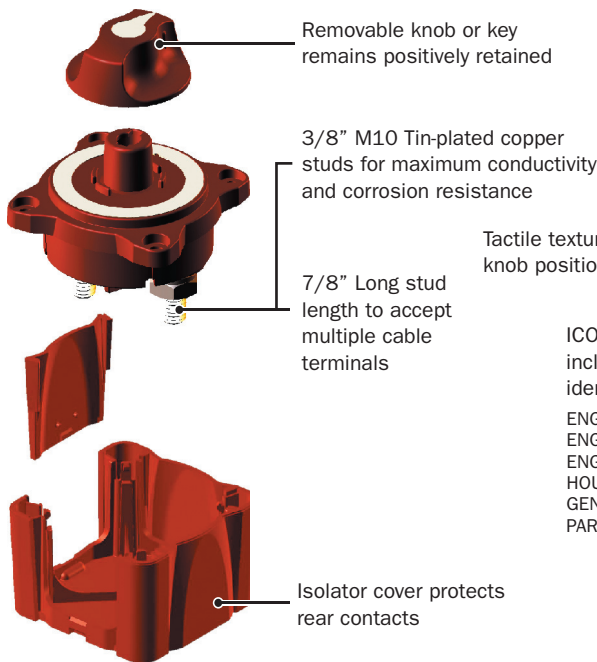

Removable knob or key remains positively retained

3/8" M10 Tin-plated copper studs for maximum conductivity and corrosion resistance

7/8" Long stud length to accept multiple cable terminals

Isolator cover protects rear contacts

Ignition protected - Safe for installation aboard gasoline powered boats

Case design allows surface, front panel, or rear panel mounting

Label with international ON/OFF legends

Tactile textures indicate knob position by feel only

ICON label set included for circuit identification

- ENGINE
- ENGINE 1
- ENGINE 2
- HOUSE
- GENERATOR
- PARALLEL

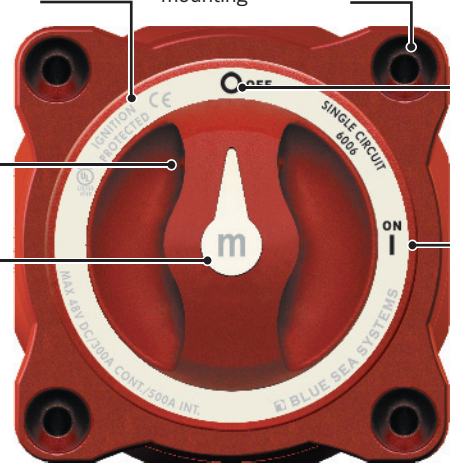

- Ideal for marine or RV applications
- Accepts up to 4/0 battery cables
- All non-corrosive marine grade metals
- Molded in durable reinforced polycarbonate



Specifications

	6005-6007	6010-6011
Inrush Rating: .25 sec (10 repeats)*	1,500 Amperes DC	1,200 Amperes DC
Cranking Rating: 9.75 sec (10 repeats)*	700 Amperes DC	500 Amperes DC
Intermittent Rating: 5 min (UL 1107)	500 Amperes DC	300 Amperes DC
Continuous Rating: (UL 1107)	300 Amperes DC	200 Amperes DC
Terminal Stud, Tin-Plated Copper	3/8" (M10)	3/8" (M10)
Torque	140 in-lbs.	140 in-lbs.
Cable Size to Meet Ratings ¹	4/0 Cables	4/0 Cables
Voltage Rating	48 Volts DC Maximum	48 Volts DC Maximum
Cable Clearance For 4/0 Cables	1.12" (25.4mm)	1.12" (25.4mm)
Case Material	Reinforced Polycarbonate	Reinforced Polycarbonate

CE marked

Agency Specifications

- UL Listed - UL 1107 electric power switches**
- Meets UL 1500 and SAE J1171 external ignition protection requirements

* Blue Sea Systems Engine Starting Standard (see page 8)

** Pending testing

¹Reducing cable size will reduce current rating

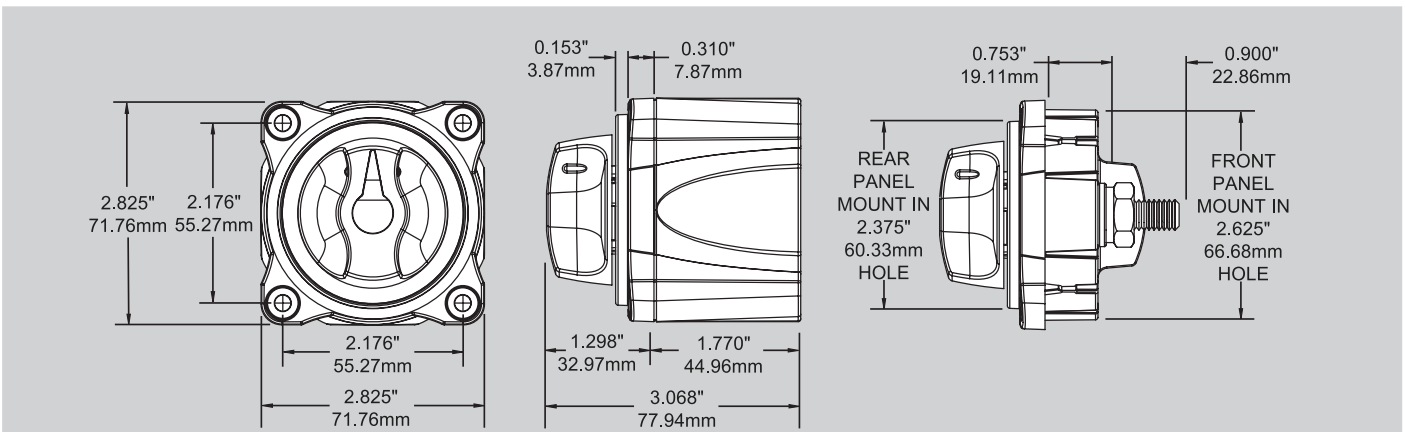
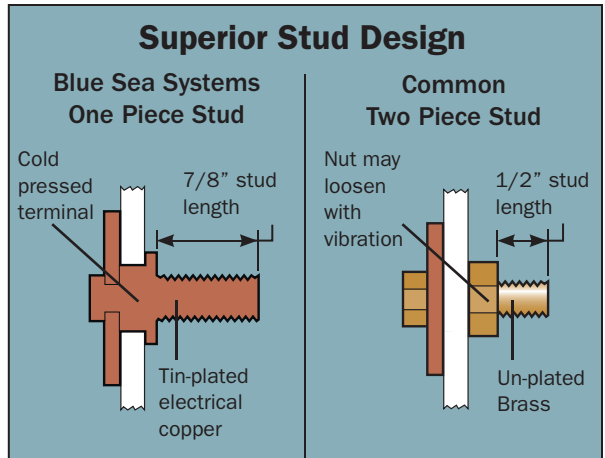

M-Series Battery Switch Dimensions



IP Single Circuit ON/OFF
6006



IP Single Circuit ON/OFF
6005

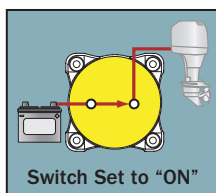

APPLICATIONS

1. Switches a single battery to a single load group.
2. Multiple switches can be used to manage several isolated circuits including cross connecting for emergency paralleling.

Note: 6005 replaces 9005
6006 replaces 9006



IP Selector 6007

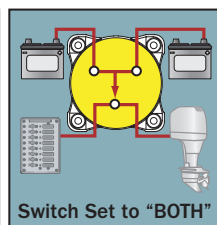
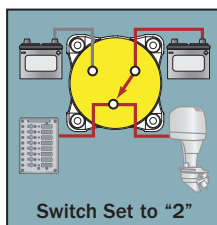
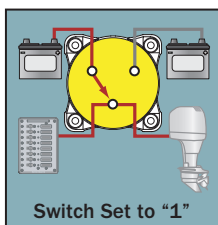

APPLICATION

Switches battery bank 1 or battery bank 2 or BOTH to a single load using one switch.



IP Dual Circuit Plus™ 6011

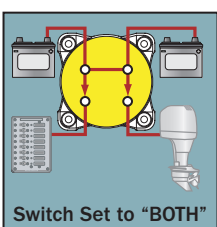
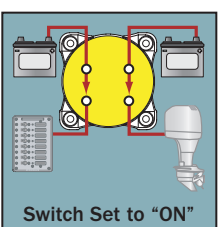

APPLICATIONS

1. Switches two battery banks simultaneously with one simple ON/OFF switch while maintaining battery bank isolation, minimizing the risk of a dead Start battery.
2. The BOTH function offers the ability to combine the two battery banks in the event of a low Start battery.



IP Dual Circuit 6010

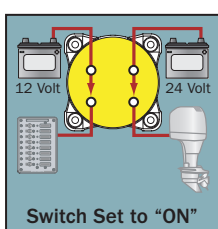

APPLICATIONS

1. Switches both positive and negative lines simultaneously with one simple ON/OFF switch meeting European and metal boat requirements for a double pole switch.
2. Switches circuits of different voltages, such as 12 Volt and 24 Volt, simultaneously with one simple ON/OFF switch.

PN	Description	Weight Lb (Kg)
6005	SINGLE CIRCUIT ON/OFF Battery Switch	0.62 (0.28)
6006	SINGLE CIRCUIT ON/OFF Battery Switch	0.63 (0.29)
6007	SELECTOR Battery Switch	0.77 (0.35)
6010	DUAL CIRCUIT Battery Switch	0.80 (0.36)
6011	DUAL CIRCUIT PLUS™ Battery Switch	0.80 (0.36)
7901	Spare Knob for PN 6006	0.10 (0.05)
7900	Spare Key for PN 6005	0.10 (0.05)
7902	Luminous ICON Circuit Identification Label Kit	0.02 (0.01)

7902 Luminous ICON Circuit Identification Label Kit	
BATTERY 1	HOUSE
BATTERY 2	BOW THRUSTER
BATTERY 3	WINDLASS
ENGINE	GENERATOR
ENGINE 1	PARALLEL
ENGINE 2	INVERTER
ENGINE PORT	WINCH
ENGINE STAR	CHASSIS
ENGINE MID	

NEW PRODUCT

IP IGNITION PROTECTED

e-Series Battery Switches

Rated the top standard-duty switch by Powerboat Reports*

350 Amperes Continuous Rating for small inboard gasoline or diesel engines

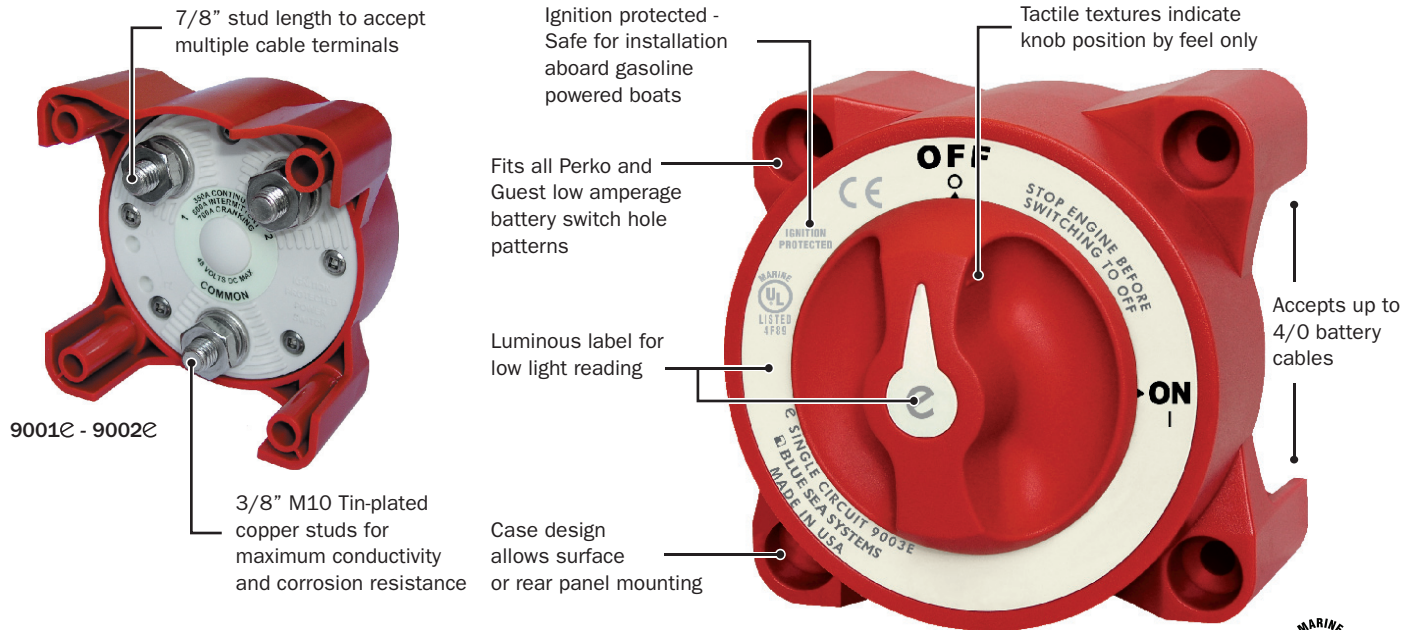

- AFD (Alternator Field Disconnect) feature on 9002E and 9004E models
- Meets all American Boat and Yacht Council (ABYC) requirements for battery switches
- Make-before-break contact design on 9001E and 9002E models allows switching between battery banks without power interruption

* "Blue Sea Systems' switch (9001e) is our choice for best value in a standard-duty battery selector switch. It's made in the U.S. with high grade materials, comes with a lifetime warranty, and is the least expensive switch in our test." - Powerboat Reports , June 2005

Specifications

	9001E-9004E	5510E-5511E
Inrush Rating: .25 sec (10 repeats)*	1,750 Amperes DC	1,500 Amperes DC
Cranking Rating: 9.75 sec (10 repeats)*	900 Amperes DC	600 Amperes DC
Intermittent Rating: 5 min (UL 1107)	600 Amperes DC	450 Amperes DC
Continuous Rating: (UL 1107)	350 Amperes DC	300 Amperes DC
Terminal Stud, Tin-Plated Copper	3/8" (M10)	3/8" (M10)
Torque	140 in-lbs.	140 in-lbs.
Cable Size to Meet Ratings ¹	4/0 Cables	4/0 Cables
Voltage Rating	48 Volts DC Maximum	48 Volts DC Maximum
Cable Clearance For 4/0 Cables	1.10" (28.0mm)	1.10" (28.0mm)
Case Material	Reinforced Polycarbonate	Reinforced Polycarbonate

CE marked

Agency Specifications

- UL Listed - UL 1107 electric power switches
- Meets UL 1500 and SAE J1171 external ignition protection requirements

* Blue Sea Systems Engine Starting Standard (see page 8)

¹ Reducing cable sizes will reduce current ratings

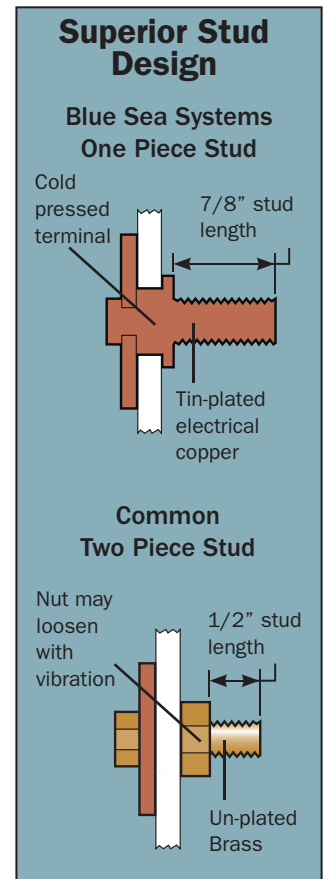
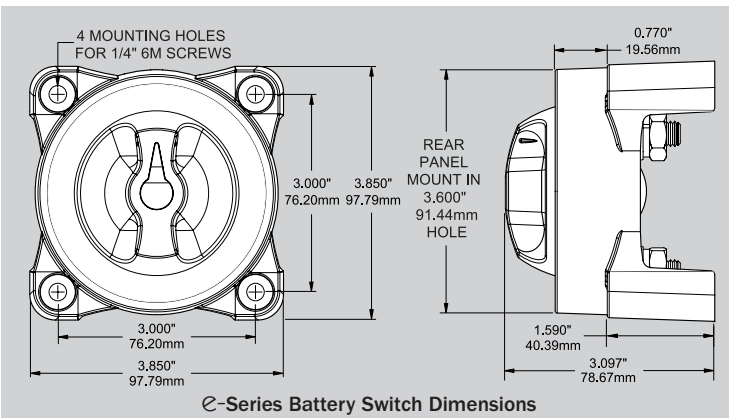

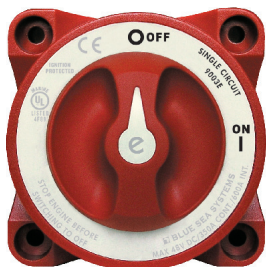

IP Single Circuit ON/OFF
9003E-9004E

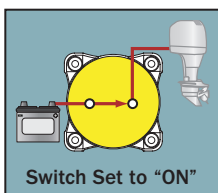

APPLICATIONS

1. Switches a single battery to a single load group.
2. Multiple switches can be used to manage several isolated circuits including cross connecting for emergency paralleling.

9004E only - includes AFD*

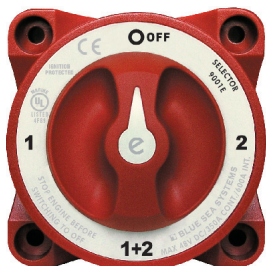

IP Selector 9001E-9002E

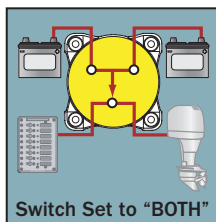
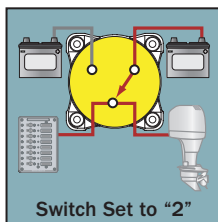
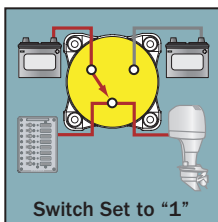

APPLICATION

9001E and 9002E switches battery bank 1 or battery bank 2 or both to a single load using one switch.
9002E only - includes AFD*

Available January, 2006



IP Dual Circuit Plus™ 5511E

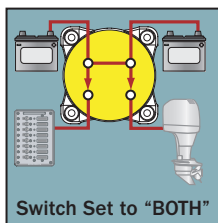
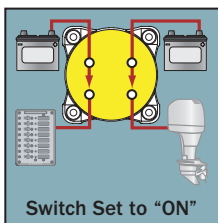

APPLICATIONS

1. Switches two battery banks simultaneously with one simple ON/OFF switch while maintaining battery bank isolation, minimizing the risk of a dead Start battery.
2. The BOTH function offers the ability to combine the two battery banks in the event of a low Start battery.

Available January, 2006



IP Dual Circuit™ 5510E

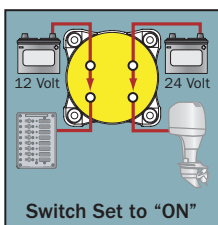

APPLICATIONS

1. Switches both positive and negative lines simultaneously with one simple ON/OFF switch meeting European and metal boat requirements for a double pole switch.
2. Switches circuits of different voltages, such as 12 Volt and 24 Volt, simultaneously with one simple ON/OFF switch.

PN	Description	AFD *	Weight Lb (Kg)
9003E	SINGLE CIRCUIT ON/OFF Battery Switch	-	0.92 (0.42)
9004E	SINGLE CIRCUIT ON/OFF Battery Switch	Yes	0.96 (0.44)
9001E	SELECTOR Battery Switch	-	1.10 (0.50)
9002E	SELECTOR Battery Switch	Yes	1.15 (0.52)
5511E	DUAL CIRCUIT PLUS™ Battery Switch	-	1.27 (0.57)
5510E	DUAL CIRCUIT Battery Switch	-	1.27 (0.57)
7902	Luminous ICON Circuit Identification Label Kit	-	0.02 (0.01)

7902 Luminous ICON Circuit Identification Label Kit	
BATTERY 1	HOUSE
BATTERY 2	BOW THRUSTER
BATTERY 3	WINDLASS
ENGINE	GENERATOR
ENGINE 1	PARALLEL
ENGINE 2	INVERTER
ENGINE PORT	WINCH
ENGINE STAR	CHASSIS
ENGINE MID	

NEW PRODUCT

IP IGNITION PROTECTED

* Alternator Field Disconnect (AFD) protects the diodes in the alternator in the event of the switch being switched to the OFF position while the engine is running.

HD-Series Battery Switches (Heavy Duty)

Up to 600 Amperes Continuous Rating for large diesel engines, high power output, and low heat generation

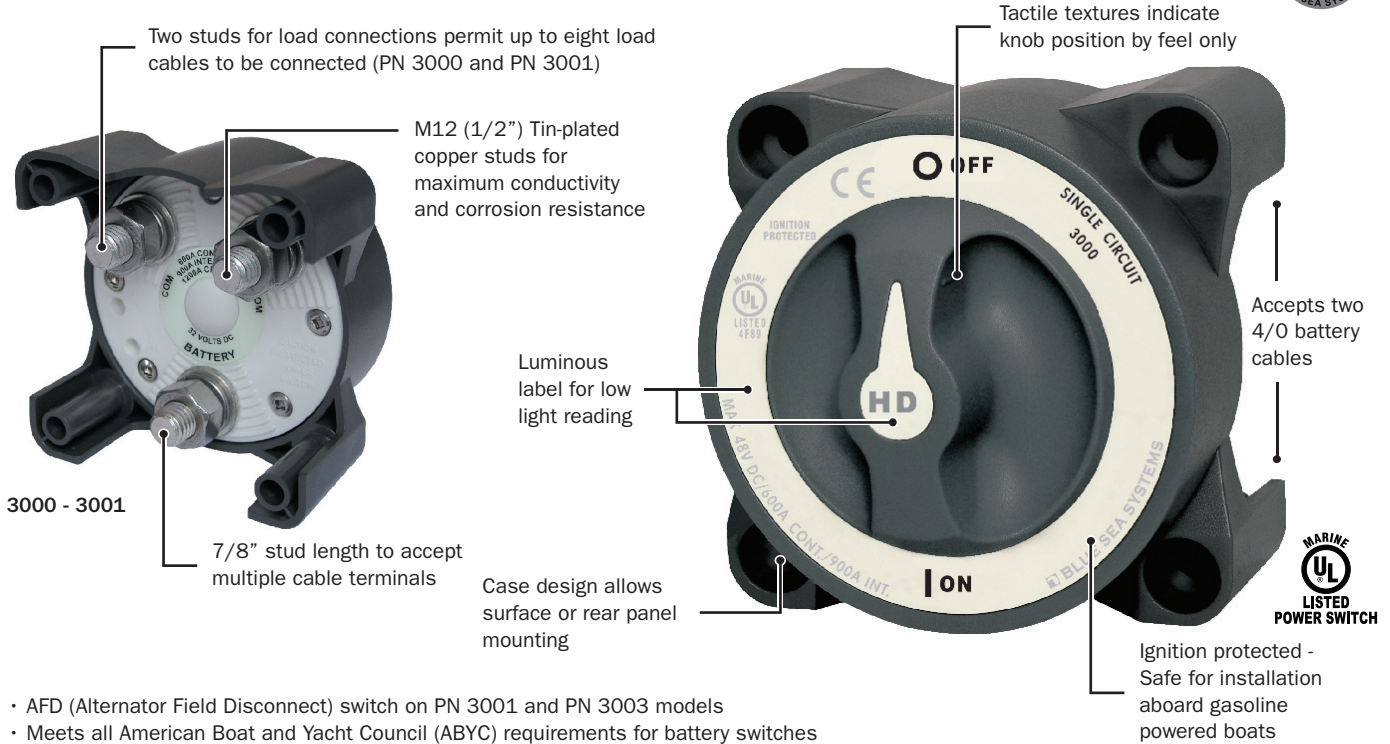

- AFD (Alternator Field Disconnect) switch on PN 3001 and PN 3003 models
- Meets all American Boat and Yacht Council (ABYC) requirements for battery switches

Specifications

	3000-3001	3002-3003
Inrush Rating: .25 sec (10 repeats)*	2,000 Amperes DC	1,750 Amperes DC
Cranking Rating: 9.75 sec (10 repeats)*	1,200 Amperes DC	1,000 Amperes DC
Intermittent Rating: 5 min (UL 1107)	900 Amperes DC	700 Amperes DC
Continuous Rating: (UL 1107)	600 Amperes DC	500 Amperes DC
Terminal Stud, Tin-Plated Copper	1/2" (M12)	1/2" (M12)
Torque	220 in-lbs.	220 in-lbs.
Cable Size to Meet Ratings ¹	4/0 Cables	4/0 Cables
Cable Quantity to Meet Ratings ¹	Two Cables ²	Two Cables ³
Voltage Rating	48 Volts DC Maximum	48 Volts DC Maximum
Cable Clearance For 4/0 Cables	1.10" (28.0mm)	1.10" (28.0mm)
Case Material	Reinforced Polycarbonate	Reinforced Polycarbonate

CE marked

Agency Specifications

- UL Listed - UL 1107 electric power switches
- Meets UL 1500 and SAE J1171 external ignition protection requirements

* Blue Sea Systems Engine Starting Standard (see page 8)

- 1 Reducing cable sizes or quantities will reduce current ratings
- 2 Two cables on battery terminal, one cable on each common terminal
- 3 Per terminal

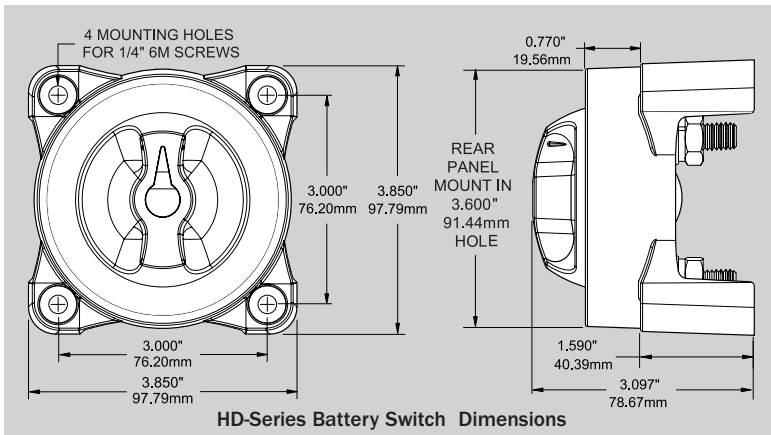
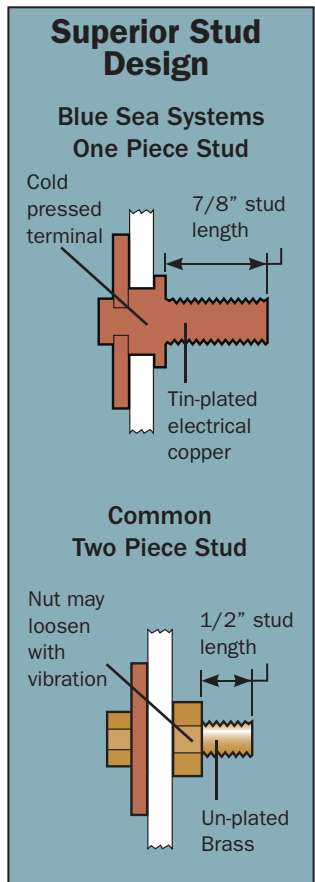

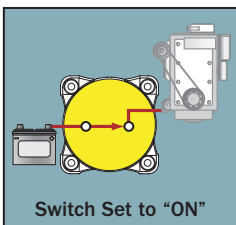
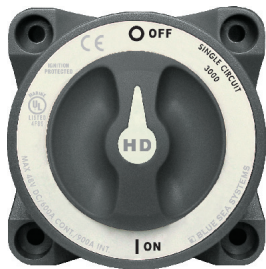

APPLICATIONS

1. Switches a single battery to a single load group.
2. Multiple switches can be used to manage several isolated circuits including cross connecting for emergency paralleling.

3001 only - includes AFD*

IP Single Circuit ON/OFF
3000-3001

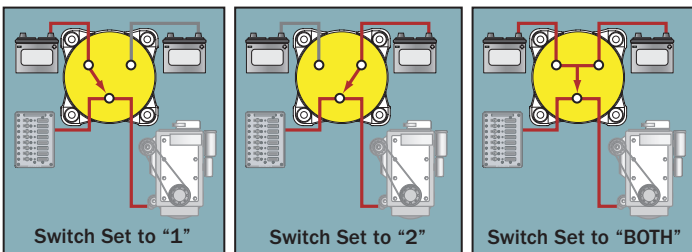
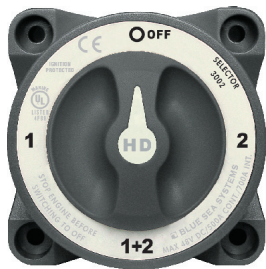

APPLICATION

3002 and 3003 switches battery bank 1 or battery bank 2 or both to a single load using one switch.
3003 only - includes AFD*

IP Selector 3002-3003

PN	Description	AFD*	Weight Lb (Kg)
3000	SINGLE CIRCUIT ON/OFF Battery Switch	-	1.20 (0.54)
3001	SINGLE CIRCUIT ON/OFF Battery Switch	Yes	1.25 (0.56)
3002	SELECTOR Battery Switch	-	1.20 (0.54)
3003	SELECTOR Battery Switch	Yes	1.25 (0.56)
7902	Luminous ICON Circuit Identification Label Kit	-	0.02 (0.01)

NEW PRODUCT

IP IGNITION PROTECTED

7902 Luminous ICON Circuit Identification Label Kit	
BATTERY 1	HOUSE
BATTERY 2	BOW THRUSTER
BATTERY 3	WINDLASS
ENGINE	GENERATOR
ENGINE 1	PARALLEL
ENGINE 2	INVERTER
ENGINE PORT	WINCH
ENGINE STAR	CHASSIS
ENGINE MID	

* Alternator Field Disconnect (AFD) protects the diodes in the alternator in the event of the switch being switched to the OFF position while the engine is running.



Updated Version Available January, 2006

Parallel Circuit Mini Battery Switch Panels UPDATED PRODUCT

Enables a failed House or Start battery bank to be isolated from the electrical system and both House and Start loads to be operated from the remaining battery bank.

- Isolates Start circuit from House circuit
- Simplifies battery switch operation
- Protects electronics from sags and spikes caused by engine cranking
- Discharges batteries independently
- Addition of an Automatic Charging Relay automates charging both batteries (see pages 24-26)
- Ignition protected - Safe for installation aboard gasoline powered boats

Specifications

Inrush Rating: .25 sec (10 repeats)*	1,500 Amperes DC
Cranking Rating: 9.75 sec (10 repeats)*	700 Amperes DC
Intermittent Rating: 5 min (UL 1107)	500 Amperes DC
Continuous Rating: (UL 1107)	300 Amperes DC
Voltage	48 Volts DC Maximum

* Blue Sea Systems Engine Starting Standard (see page 8)

CE marked

Agency Specifications

- All components meet SAE J1171 external ignition protection requirements



IP 8280



IP 8370

Panel PN	Installed Battery Switch PN	Battery Switch Pages	Width in" (mm)	Height in" (mm)	Weight Lb (Kg)
8280	M-Series SINGLE CIRCUIT ON/OFF 3 of 6006	13-14	6.25 (158.75)	7.50 (190.50)	2.98 (1.35)
8370	M-Series SINGLE CIRCUIT ON/OFF 3 of 6006	13-14	9.50 (95.25)	3.75 (95.25)	2.30 (1.04)

Combine with Blue Sea Systems CL-Series BatteryLink™ ACR (see page 24, 26) for a complete DC management solution.

UPDATED PRODUCT

IP IGNITION PROTECTED

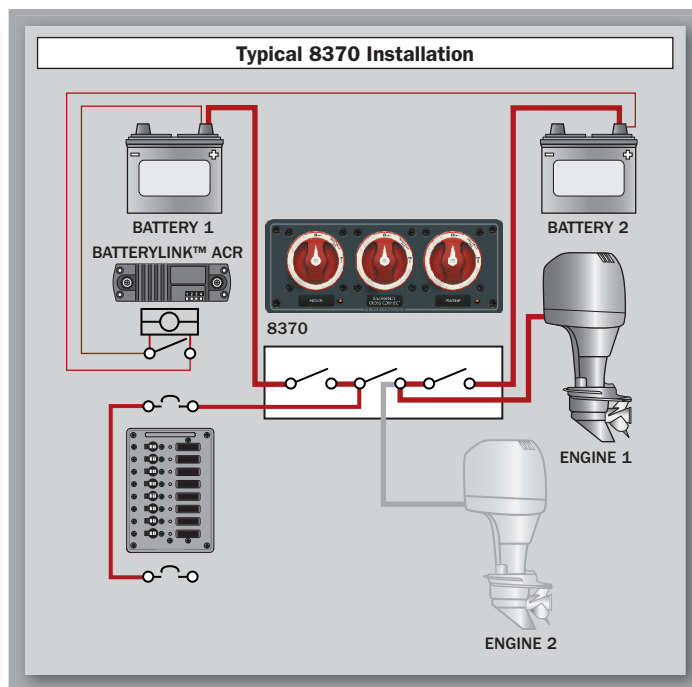
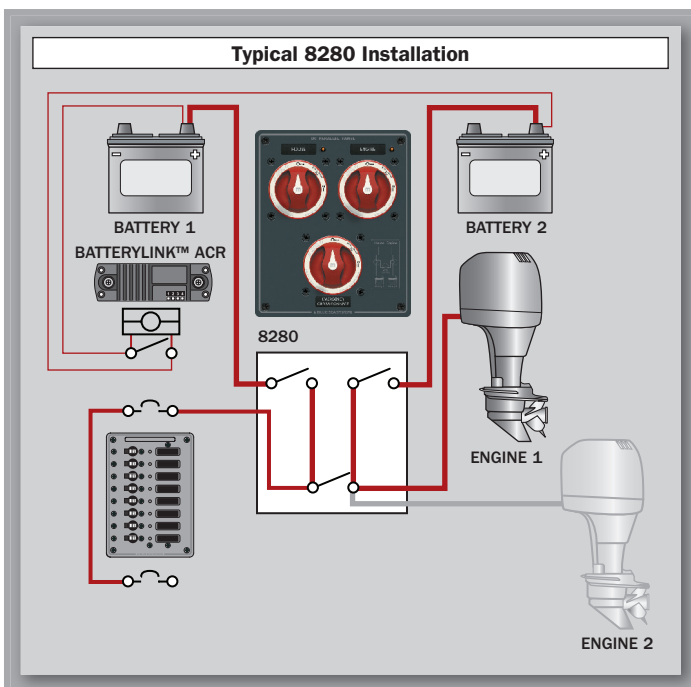

Updated Version Available January, 2006

Parallel Circuit Mini Battery Switch Plus Main Panel UPDATED PRODUCT

Isolates batteries and provides DC main circuit protection.

- Ignition protected - Safe for installation aboard gasoline powered boats
- Isolates the Start circuit from the House circuit
- Simplifies battery switch operation
- Protects electronics from sags and spikes caused by engine cranking
- Discharges batteries independently
- Addition of an Automatic Charging Relay automates charging of both batteries (see pages 24-26)
- Enables a failed Start battery to be isolated from the electrical system and both House and Start loads to be operated from the remaining battery bank
- Provides main circuit protection for DC House power system



IP 8080

Specifications

Inrush Rating: .25 sec (10 repeats)*	1,500 Amperes DC
Cranking Rating: 9.75 sec (10 repeats)*	700 Amperes DC
Intermittent Rating: 5 min (UL 1107)	500 Amperes DC
Continuous Rating: (UL 1107)	300 Amperes DC
Voltage	48 Volts DC Maximum
House Circuit Protection	100 Amperes DC

* Blue Sea Systems Engine Starting Standard (see page 8)

Agency Specifications

- All components meet SAE J1171 external ignition protection requirements

Combine with Blue Sea Systems CL-Series BatteryLink™ ACR (see page 24, 26) for a complete DC management solution.

Panel PN	Installed Battery Switch PN	Battery Switch Pages	Width in" (mm)	Height in" (mm)	Weight Lb (Kg)
8080	M-Series SINGLE CIRCUIT ON/OFF 6006, 6005	13-14	5.25 (133.40)	6.50 (165.10)	2.20 (1.00)

UPDATED PRODUCT

IP IGNITION PROTECTED

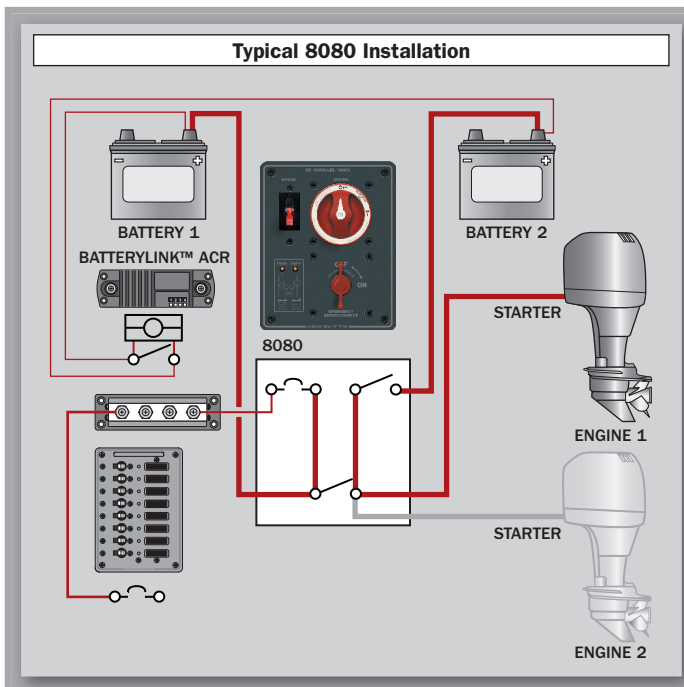

Available January, 2006

Dual Battery Main Distribution Panels NEW PRODUCT

- Available in four configurations
- Each panel can be mounted in four different orientations
- Isolates the Start circuit from the House circuit
- Simplifies battery switch operation
- Protects electronics from sags and spikes caused by engine cranking
- Discharges batteries independently
- Addition of an Automatic Charging Relay automates charging both batteries (see pages 24-26)
- Designed for single engine configurations
- Allows emergency cross connect between separate engine battery banks
- Provides main DC circuit protection in addition to high ampere loads
- Provides 24 hour circuit protection
- Includes 4218 - Set of 30 common DC labels (see page 89)

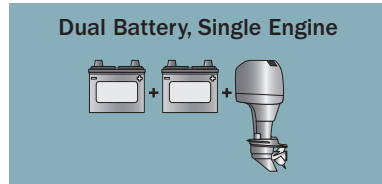

8686

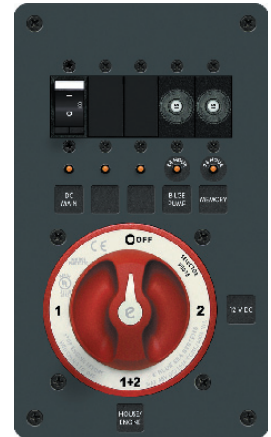

8691

Specifications	8686	8687	8690	8691
Inrush Rating: .25 sec (10 repeats)*	1,200 Amperes DC	1,500 Amperes DC	1,500 Amperes DC	1,750 Amperes DC
Cranking Rating: 9.75 sec (10 repeats)*	500 Amperes DC	700 Amperes DC	600 Amperes DC	900 Amperes DC
Intermittent Rating: 5 min (UL 1107)	300 Amperes DC	500 Amperes DC	450 Amperes DC	600 Amperes DC
Continuous Rating: (UL 1107)	200 Amperes DC	300 Amperes DC	300 Amperes DC	350 Amperes DC
Voltage	12-24 Volts DC	12-24 Volts DC	12-24 Volts DC	12-24 Volts DC
House Circuit Protection	100 Amperes DC	100 Amperes DC	100 Amperes DC	100 Amperes DC

* Blue Sea Systems Engine Starting Standard (see page 8)

Panel PN	Installed Battery Switch PN	Switch Pages	Width in" (mm)	Height in" (mm)	Installed Large Case Rocker Circuit Breaker	Installed Push Button Circuit Breakers
					100A	15A
8686	M-Series, DUAL CIRCUIT PLUS™ 6011	12-13	4.50 (114.30)	7.50 (190.50)	1	2
8687	M-Series, SELECTOR 6007	12-13	4.50 (114.30)	7.50 (190.50)	1	2
8690	E-Series, DUAL CIRCUIT PLUS™ 5511E	14-15	5.25 (139.70)	9.00 (228.60)	1	2
8691	E-Series, SELECTOR 9001E	14-15	5.25 (139.70)	9.00 (228.60)	1	2

NEW PRODUCT

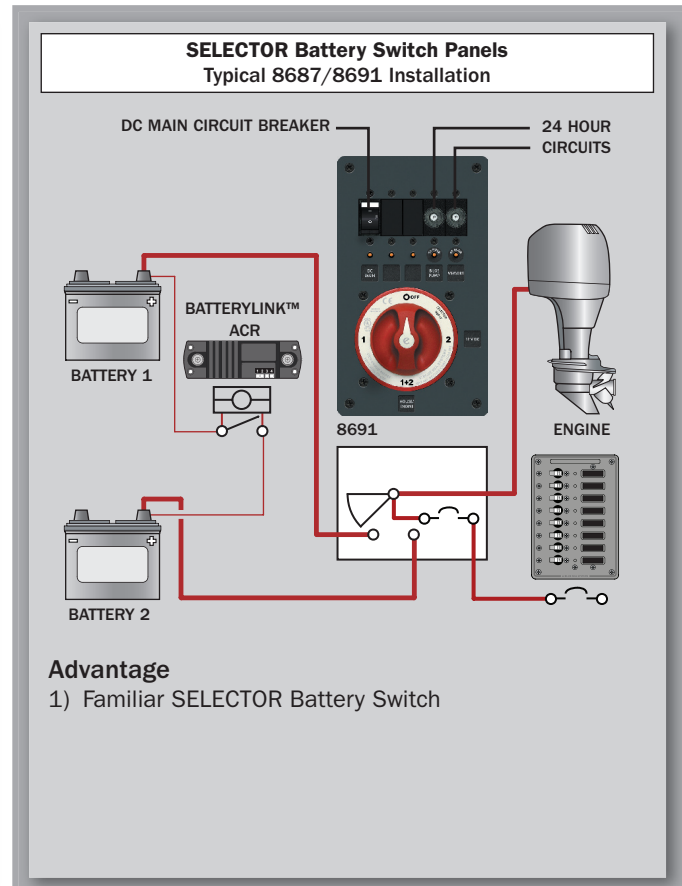
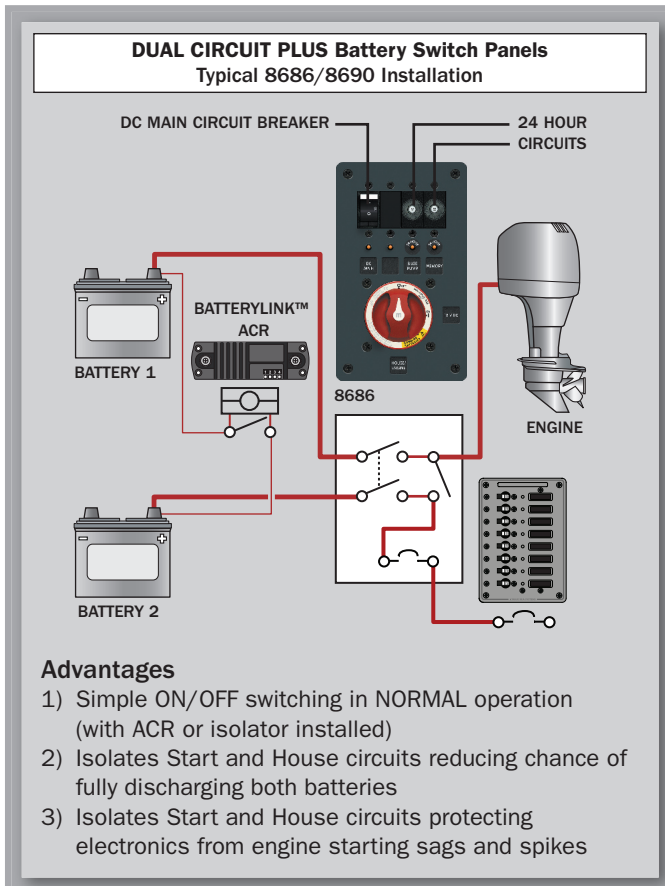

Available January, 2006

Triple Battery Main Distribution Panels NEW PRODUCT

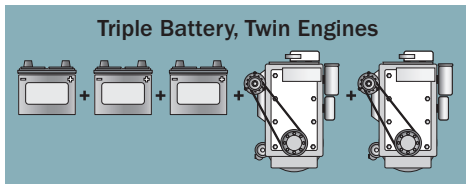

- Available in two configurations
- Each panel can be mounted in four different orientations
- Isolates the Start circuit from the House circuit
- Simplifies battery switch operation
- Protects electronics from sags and spikes caused by engine cranking
- Discharges batteries independently
- Addition of an Automatic Charging Relay automates charging both batteries (see page 24-26)
- Designed for twin engine configurations
- Allows emergency cross connect between separate engine battery banks
- Provides main DC circuit protection in addition to high ampere loads
- Provides 24 hour circuit protection
- Includes 4218 - Set of 30 common DC labels (see page 89)



8689



8693

Specifications

	8689	8693
Inrush Rating: .25 sec (10 repeats)*	1,200 Amperes DC	1,500 Amperes DC
Cranking Rating: 9.75 sec (10 repeats)*	500 Amperes DC	600 Amperes DC
Intermittent Rating: 5 min (UL 1107)	300 Amperes DC	450 Amperes DC
Continuous Rating: (UL 1107)	200 Amperes DC	300 Amperes DC
Voltage	12-24 Volts DC	12-24 Volts DC
House Circuit Protection	100 Amperes DC	100 Amperes DC

* Blue Sea Systems Engine Starting Standard (see page 8)

Panel PN	Installed Battery Switch PN's	Switch Pages	Width in" (mm)	Height in" (mm)	Installed Large Case Rocker Circuit Breaker	Installed Push Button Circuit Breakers
					100A	15A
8689	M-Series, DUAL CIRCUIT PLUS™ 2 of 6011	12-13	7.25 (184.15)	8.00 (203.20)	1	3
8693	e-Series DUAL CIRCUIT PLUS™ 2 of 5511e	12-13	10.00 (254.00)	9.00 (228.60)	1	4

NEW PRODUCT

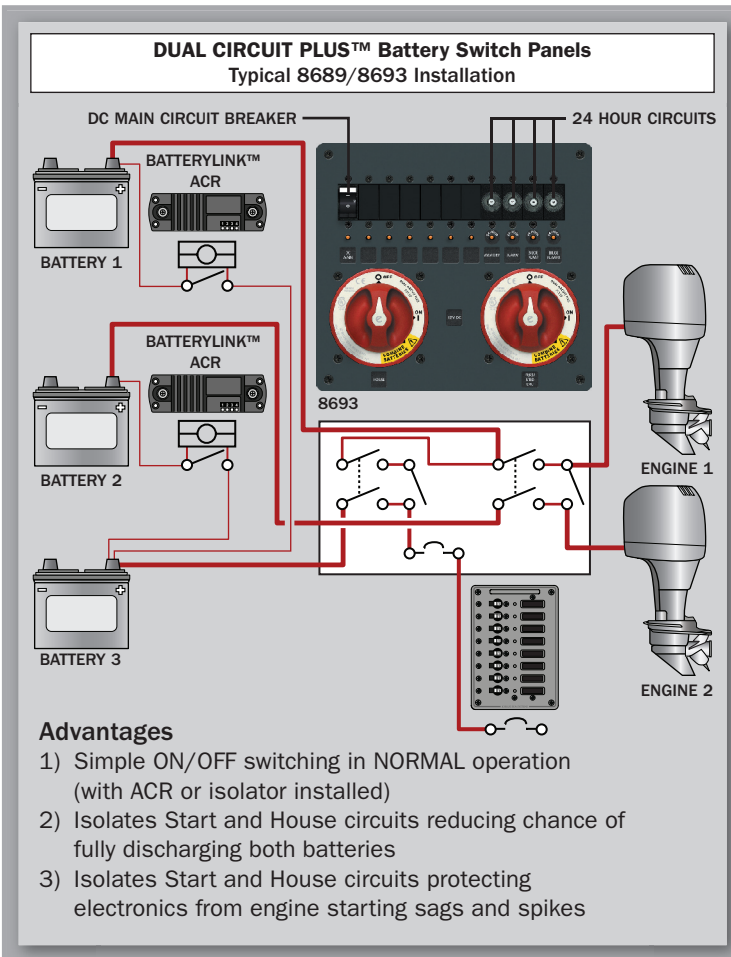

Advantages

- 1) Simple ON/OFF switching in NORMAL operation (with ACR or isolator installed)
- 2) Isolates Start and House circuits reducing chance of fully discharging both batteries
- 3) Isolates Start and House circuits protecting electronics from engine starting sags and spikes

L-Series Solenoid Switch with Coil Economizer

250 Ampere Class, 12/24 Volt

- Hermetically sealed contacts
- Vaporproof
- Ignition protected - Safe for installation aboard gasoline powered boats
- Pulse circuit requires low current draw when contact is closed
- UL Recognized - UL 508 industrial control equipment
- Meets SAE J1171 - External ignition protection requirements
- Functions as a remote battery switch
- Activated by an ON-OFF switch mounted anywhere
- Used as a manual battery paralleling switch
- Integrated coil control minimizes heating and amperage draw



IP 9012



(Optional)

8230 · Provides ON/OFF switching

▶ See page 55 for full selection of Contura Rocker Switches and accessories.

Specifications

Coil Circuit

Input Voltage	9-36 Volts DC Maximum
Power Consumption	
- inrush max, 130ms	12-36 Volts/3.80 Amperes
- holding	12 Volts/0.13 Amperes 24 Volts/0.07 Amperes

Main Power Contacts

Inrush Rating: 0.25 sec. (10 repeats)*	2,000 Amperes DC
Voltage Rating	60 Volts DC
Stud Terminal Size	5/16" (M8)
Contact Form	SPST-NO
Mechanical Life	1,000,000 Cycles

CE marked

Wire Size	Cranking Rating 9.75 sec. (10 repeats)*	Intermittent Rating 5 min. (UL 1107)	Continuous Rating (UL 1107)
1/0	450A	375A	250A
2/0	500A	450A	300A
2x2/0	800A	600A	450A

* Blue Sea Systems Engine Starting Standard (see page 8)

PN	Description	Weight Lb (Kg)
9012	250 Ampere Class, 12/24 Volt Solenoid with Coil Economizer	0.95 (0.43)

IP IGNITION PROTECTED

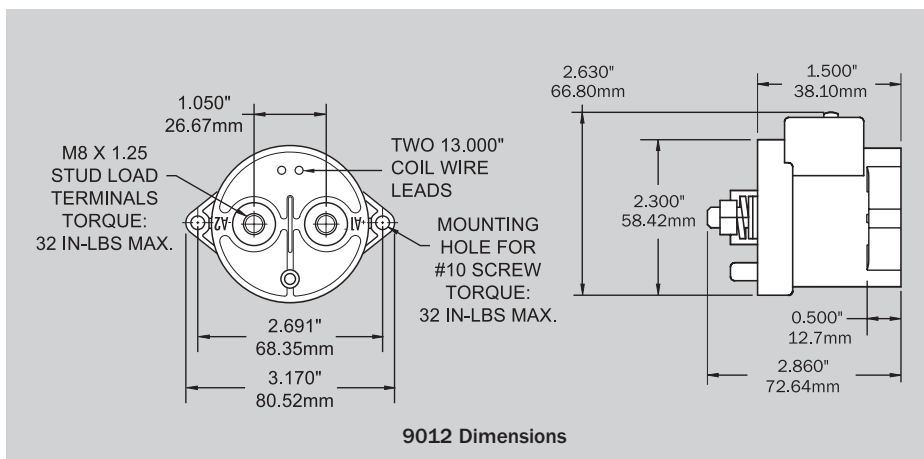
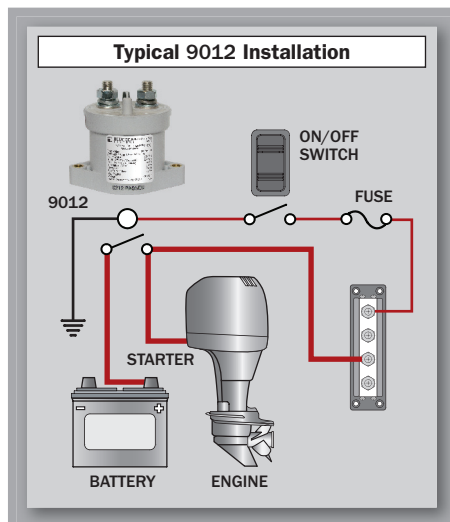

CL-Series BatteryLink™ ACR (Current Limiting)

with Over Current Protection

- Automatically combines battery banks during the charging cycle and isolates under discharge
- Activates from any charging source - alternators, battery chargers, or solar panels
- Senses charge voltages on up to two battery banks
- Sealed contact assembly
- Meets SAE J1171 - External ignition protection requirements
- Noise free circuitry will not interfere with other devices
- Limits current flow allowing smaller wire size
- Low current draw when closed: <0.2A

Specifications

Coil Circuit

Input Voltage 9-16 Volts Maximum

Main Power Contacts

Voltage Rating 16 Volts DC for 12 Volts DC Nominal Systems

Contact Form SPST-NO

Stud Terminal Size 3/8" (M10)

Mechanical Life 1,000,000 Cycles

Automatic Operation

Automatically combines when the higher battery has remained at the required voltage for at least 30 seconds. The CL-Series BatteryLink™ ACR disconnects when the voltage drops below the charging voltage to prevent accidental discharge of an unintended bank.

Manual Operation

When connected to an optional ON-OFF-ON switch the CL-Series BatteryLink™ ACR can be turned off, set to automatic, or manually combined.

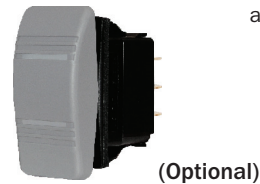
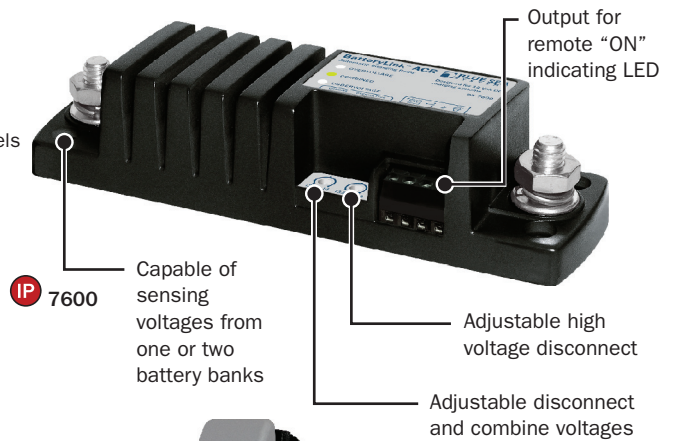

- 8232** (Optional)
- Provides manual operation explained at left
 - ▶ See page 55 for full selection of Contura Rocker Switches and accessories.

NEW PRODUCT



- 8270** (Optional)
- Provides manual operation explained at left

PN	Description	Weight Lb (Kg)
7600	CL-Series BatteryLink™ ACR with over current protection	0.63 (0.29)
8232	Contura Rocker Switch	0.24 (0.11)
8270	Switch Panel	0.27 (0.12)

The BatteryLink™ ACR may also be used as a DC Low Voltage Disconnect (DC Load Manager) and as a means for charging a battery installed at a distance from a main battery bank (Battery Link). For these uses, please see the Application Brief section of our website at www.bluesea.com.



Automatic Charge Relay Operation

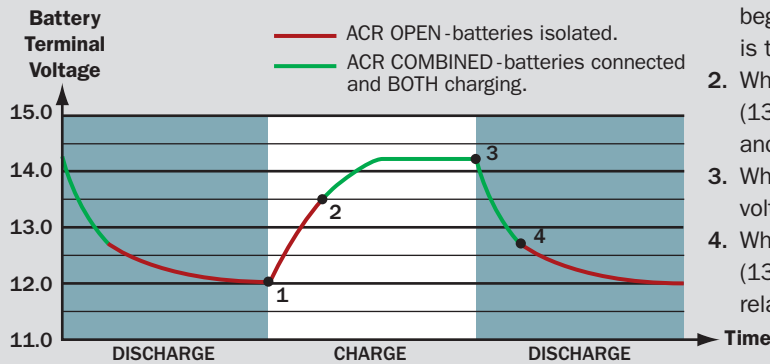

1. ACR relay is open and batteries are isolated. Voltage begins to rise slowly after engine starts or battery charger is turned on.
2. When voltage rises to "COMBINE" voltage set on ACR (13.5 volts in this example), ACR relay closes, connecting and charging both batteries.
3. When engine stops or battery charger is turned off, voltage rapidly begins falling.
4. When voltage falls to 6% less than "COMBINE" voltage (13.5 volts 6% = 12.7 volts in this example), ACR relay opens isolating batteries after 1 minute.

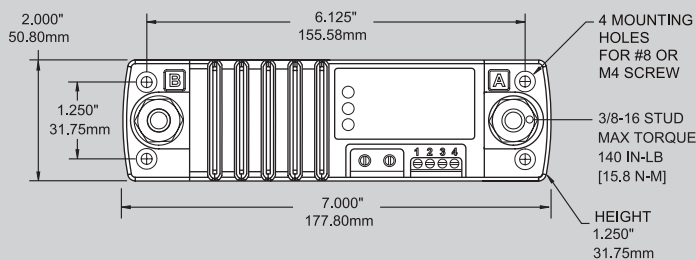

7600 Dimensions

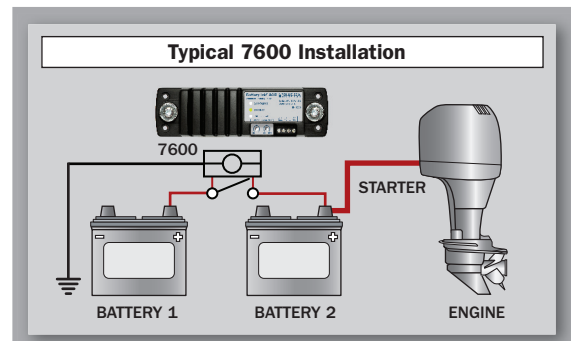



IP 9112

L-Series ACR with Coil Economizer

250 Ampere Class, 12/24 Volt

- Hermetically sealed contacts
- Vaporproof
- Ignition protected - Safe for installation aboard gasoline powered boats
- Single or double sensing
- Pulse circuit requires very low current draw when contact is closed
- UL Recognized - UL 508 industrial control equipment
- Meets SAE J1171 - External ignition protection requirements
- Automatically connects battery banks during the charging cycle and disconnects under discharge
- Override for emergency engine paralleling to start an engine
- Activates whether the charging source is an alternator or battery charger
- Output for "ON" indicating LED
- Integrated coil control minimizes heating and amperage draw



(Optional)

8232

- Provides manual operation explained at left
- ▶ See page 55 for full selection of Contura Rocker Switches and accessories.

NEW PRODUCT



(Optional)

8270

- Provides manual operation explained at right

Specifications

Coil Circuit

Input Voltage	9-36 Volts Maximum
Power Consumption	
– inrush max, 130ms	12-36 Volts/3.80 Amperes
– holding	12 Volts/0.13 Amperes, 24 Volts DC/0.07 Amperes

Main Power Contacts

Inrush Rating: 0.25 sec. (10 repeats)*	2,000 Amperes DC
Voltage Rating	60 Volts DC
Stud Terminal Size	5/16" (M8)
Contact Form	SPST-NO
Mechanical Life	1,000,000 Cycles

Automatic Operation

Automatic closure occurs when the higher battery has remained at the required voltage for at least 30 seconds. The ACR opens when the voltage drops below the charging voltage to prevent accidental discharge of an unintended bank.

	Relay Contact Position		
	Combine	Open Low	Open High
12 Volt System	13.6V	12.6V	15.0V
24 Volt System	27.2V	25.2V	30.0V

Manual Operation

When connected to an ON-OFF-ON switch the ACR can be turned off, set to Automatic, or manually closed.

Wire Size	Cranking Rating 9.75 sec. (10 repeats)*	Intermittent Rating 5 min. (UL 1107)	Continuous Rating (UL 1107)
1/0	450A	375A	250A
2/0	500A	450A	300A
2x2/0	800A	600A	450A

*Blue Sea Systems Engine Starting Standard (see page 8)

PN	Description	Weight Lb (Kg)
9112	250 Ampere Class, 12/24 Volt ACR with Coil Economizer	0.95 (0.43)
8232	Water Resistant Contura Rocker Switch	0.24 (0.11)
8270	Switch Panel	0.27 (0.12)



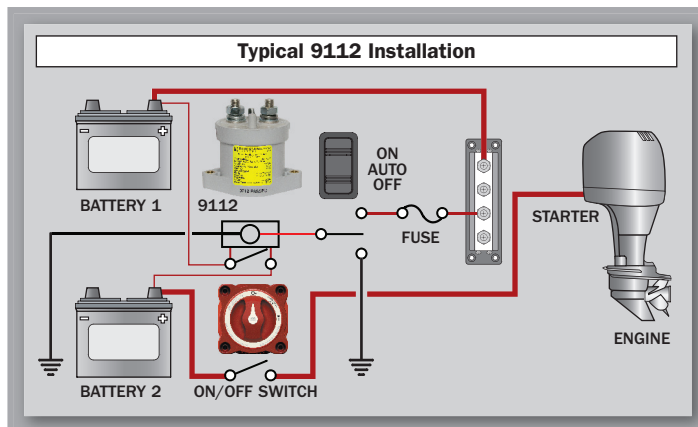
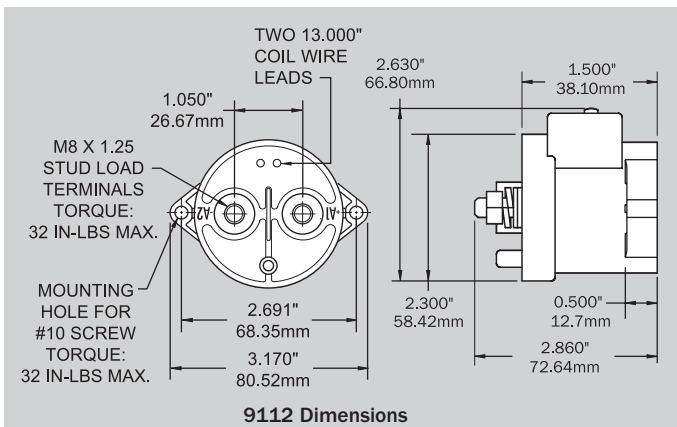





IP IGNITION PROTECTED

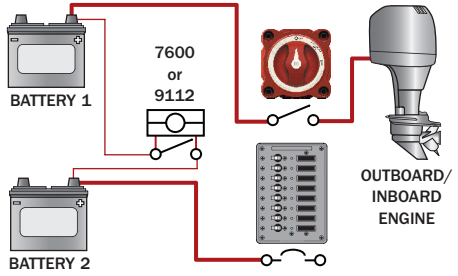

7600 BATTERYLINK™ ACR and 9112 ACR Comparison

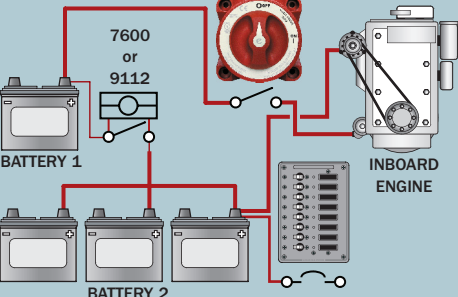
Features	7600	9112
Auto Current Management	Yes	No
High Amperage Contacts	No	Yes
High Voltage Adjustability	Yes	No
Adjustable Combining	Yes	No
Manual Override	Yes	Yes
System Voltage	12 Volts	12/24 Volts

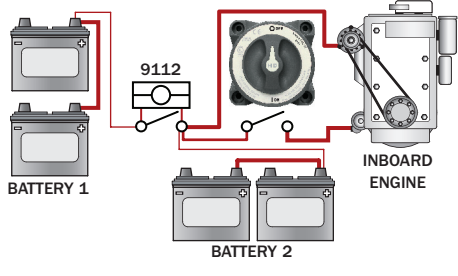
Ratings	7600	9112
Continuous	60 Amperes	250 Amperes
7 Minute	90 Amperes	275 Amperes
2 Minute	120 Amperes	600 Amperes

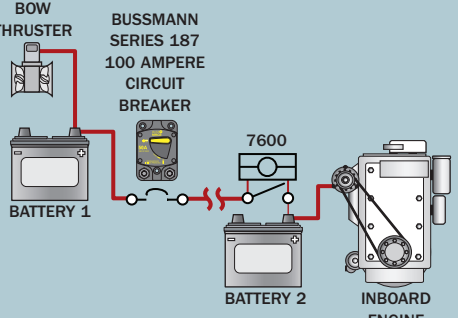
Applications	7600	9112	Schematic Diagrams
Fishing or Sport Boats <ul style="list-style-type: none"> • Outboard / small Inboard • Charge priority is to the Start battery 			
Sailing Auxiliary or Power Boats with a Large House Battery <ul style="list-style-type: none"> • Small inboard • Charge priority is to the House battery 			
Large Power Cruisers <ul style="list-style-type: none"> • Large Inboard engine • Large alternator • Charges either House or Start batteries 	Does Not Apply		
Remote Battery Charging For: <ul style="list-style-type: none"> • Anchor Windlasses • Bow Thrusters • Nav Station 		Does Not Apply	

DC Main Circuit Protection - the fuses and circuit breakers that are closest to the batteries

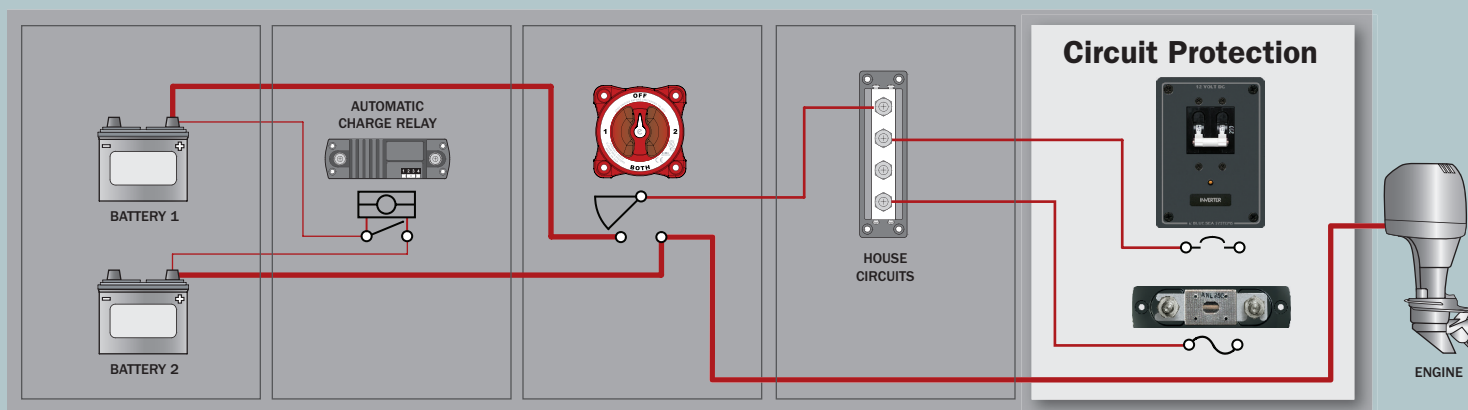

Purpose

Fuses and circuit breakers are used to protect wire insulation from melting and starting fires in the event of over currents or to protect from short circuits which cause more amperage to flow in a wire than that wire is rated to handle. It is important to note that, except for those wires that are intended to carry starting currents, every positive wire in the DC Main Power Distribution System must be protected by a fuse or circuit breaker.

Considerations

1) Ignition Protection

ABYC E-11.5.1.3 and US Coast Guard regulations require that electrical sources of ignition located in spaces containing gasoline powered machinery, gasoline fuel tanks, locations where fumes from gasoline or LP gas fumes can accumulate, comply with standards for ignition protection. To be ignition protected, these devices must have any spark producing mechanisms sealed and low enough surface temperatures that they will not ignite gas fumes. Even diesel powered vessels have suffered major fires and explosions as a result of fumes from dinghy fuel or stored painting supplies. Switches, circuit breakers, and fuses are all considered to be potential sources of ignition. Many of the circuit protection devices offered by Blue Sea Systems comply with ignition protection standards and are identified on the Circuit Protection Device Comparison Table on page 29 with an **IP** icon.

2) Mounting Placement

a) Distance from power source

The DC Main circuit protection system uses circuit breakers or fuses to protect the wires of the DC main distribution system. The American Boat and Yacht Council (ABYC) publishes voluntary standards for the type and placement of the fuse or circuit breaker to be used as a DC main circuit protection device.

The diagram below shows the required placement of main circuit protection devices. Note that wire intended to carry engine starting currents between the batteries, the switch and the starter, is not required to have main circuit protection devices installed.

Mounting placement dimensions for a fuse or circuit breaker:

- 7" if the conductor is not housed in a sheath or enclosure in addition to the wire insulation
- 40" if the conductor is housed in a sheath or enclosure in addition to the wire insulation
- 72" if the conductor is connected directly to the battery and housed in a sheath or enclosure in addition to the wire insulation

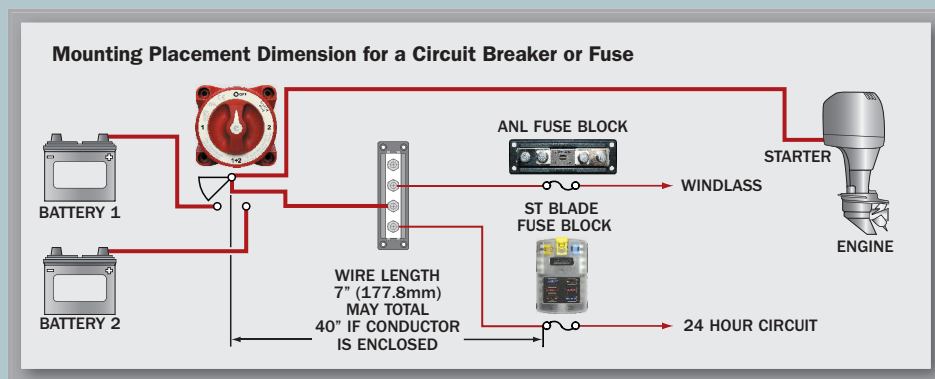

b) Above or below deck?

Most circuit protection devices are designed to be used in a protected environment; below deck in a boat with an enclosed cabin, or inside a console or locker in an open boat. There are a number of electrical panels designed for exterior mounting and designated waterproof or water resistant. In some cases, the selection of a circuit protection panel will be made on the basis of the environment where it will be mounted.

c) Wire Installation

Most circuit protection devices suitable for marine use are designed to have wires connected using ring terminals, but a few are designed to accept push-on connectors. Because large wire sizes may be chosen to minimize voltage drop in low voltage DC systems, the wire choice may make one circuit protection device more suitable than another. If large conductors are used, you may want to choose protective devices that can accommodate and support larger wire. In some cases the wire may be so large that it is necessary to place a power post or wire connection point near the circuit protection device and transition from the large wire to a smaller wire to connect to the protection device.

Questions to answer when selecting the type and size of fuse or circuit breaker:

1) Do I need a fuse or circuit breaker?

Fuse advantages:

- Generally lower cost
- Available in higher amperage ratings
- Available in higher interrupt ratings
- Available in greater size ranges

Circuit Breaker advantages:

- Re-settable after opening
- Can be used as a switch
- Available in vaporproof or waterproof models
- A wide range of opening speed characteristics are available

If the application requires the circuit protection device to be in an explosive area, as in a, b, or c below, then an ignition protected circuit breaker or fuse is required:

- a) Gasoline engine room or other area susceptible to gasoline fumes
- b) Battery compartments
- c) Propane lockers

2) What Interrupt Rating or Ampere Interrupt Capacity (AIC) is required?

See the ABYC Interrupt Rating Table on the following page.

Limit the selection to a fuse or circuit breaker type that meets the AIC of each.

3) What type of circuit protection device meets the AIC rating requirements from step 2?

See the Circuit Protection Device Comparison Table on the following page.

4) Does the circuit protection device need to be ignition protected?

See the  icon on the Circuit Protection Comparison Table on following page.

5) What should the appropriate Amperage rating be for the circuit protection device?

- a) The rating must be lower than the ampacity of the smallest wire in the circuit.

See the ABYC Ampacity Rating Table below.

- b) The rating must be higher than the maximum continuous current that will flow in the circuit.

* Special considerations should be made for electrical systems that exceed 32 Volts

** There are other issues that may be considered by reading ABYC E-11.12 circuit protection

ABYC Ampacity* Rating Table



Allowable amperage of conductors under 50 Volts with 105°C insulation						
AWG Wire Size	Metric (Sq mm)	AWG CM Area	SAE CM Area	Ohms /1000ft	Ampacity Engine Space	
					Outside	Inside
18	0.8	1,600	1,537	6.385	20	17
16	1	2,600	2,336	4.016	25	21
14	2	4,100	3,702	2.525	35	29
12	3	6,500	5,833	1.588	45	38
10	5	10,500	9,343	0.9989	60	51
8	8	16,800	14,810	0.6282	80	68
6	13	26,600	24,538	0.3951	120	102
4	19	42,000	37,360	0.2485	160	136
2	32	66,500	62,450	0.1563	210	178
1	40	83,690	77,790	0.1239	245	208
0	50	105,600	98,980	0.09827	285	242
2/0	62	133,100	125,100	0.07793	330	280
3/0	81	167,800	158,600	0.06180	385	327
4/0	103	211,600	205,500	0.04901	445	378

* Thermally limited amperage capacity

Selecting DC Main Circuit Protection

DC Main Circuit Protection Devices are characterized by one principal attribute, their Ampere Interrupt Capacity (AIC) rating. Specifications listed in the ABYC standards determine the AIC a Main Circuit Protection Device must have. The total Cold Cranking Amperes (CCA) of the batteries installed that can be connected to the circuit to be protected determine the required AIC rating. See the tables on the following page, for the required AIC ratings.

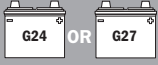
ABYC Interrupt Rating Table

Total Connected Battery Cold Cranking Amperes (CCA) *	Ampere Interrupt Capacity	
12 VOLTS AND 24 VOLTS		
The white boxes identify two batteries, of the same size, placed in parallel configuration.	DC MAIN	DC BRANCH
 650 CCA or Less	1,500 AIC	750 AIC
 651-1,100 CCA	3,000 AIC	1,500 AIC
 Over 1,100 CCA	5,000 AIC	2,500 AIC
32 VOLTS		
1,250 CCA or Less	3,000 AIC	1,500 AIC
Over 1,250 CCA	5,000 AIC	2,500 AIC

* Battery cold cranking performance rating at 17.8°C (0°F) - The discharge load in amperes that a battery at 17.8°C (0°F) can deliver for 30 seconds, and maintain a voltage of 1.2 Volts per cell or higher. eg. 7.2 Volts for a 12 Volt battery.
 The CCA for the batteries represented is an approximation and could be slightly higher or lower. Consult the battery manufacturers specifications for precise CCA ratings.

ABYC standard E-11 requires that only circuit breakers be applied according to the above table and requires that the circuit breaker can be reset and reusable. The standard does not strictly require that fuses be applied in the same way, but it is an issue to consider, especially with high amperage fuses used to protect panel feeders or inverters. Fuses under 10 Ampere rating generally have such a high internal resistance they prevent fault currents from reaching 1000 Amperes in 12 Volt circuits. The apparent contradiction when using these fuses for bilge pumps and other circuits directly off the battery is less an issue than it might seem. If a fuse blows, and the case appears to be cracked or metal has been ejected, the fuse holder should be replaced.

Circuit Protection Device Comparison Table

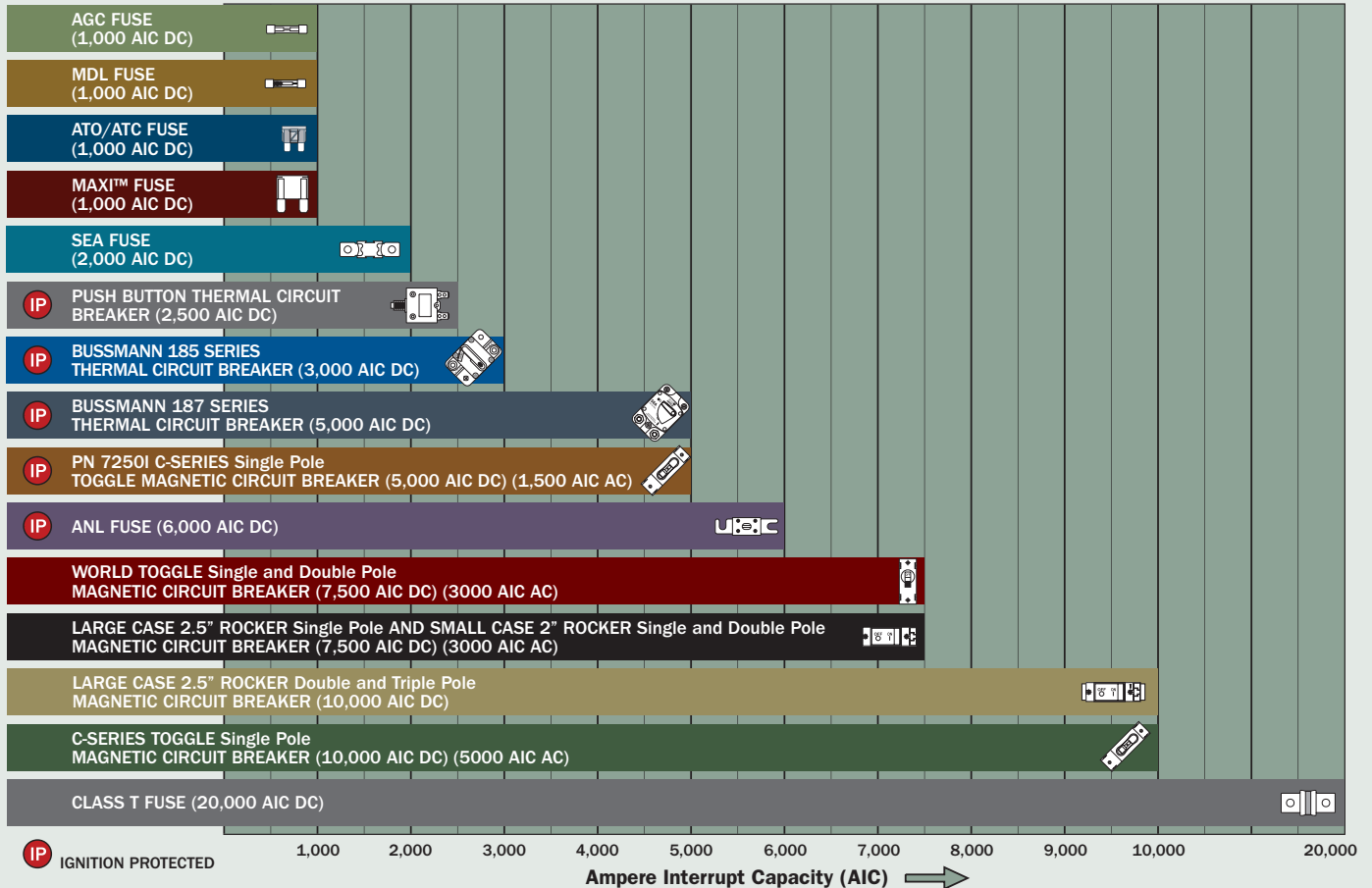

© Copyright 2006 Blue Sea Systems, Inc.

Bussmann Series 185 Circuit Breakers

- Ignition protected - Safe for installation aboard gasoline powered boats
- All components meet SAE J1171 external ignition protection requirements
- Waterproof
- Combines switching and circuit breaker function into one unit
- "Trip Free" - cannot be held closed after trip

Specifications

Interrupt Capacity 3,000 Amperes DC
 Circuit Breaker Type Thermal
 Case Material Phenolic
 Maximum Voltage 42 Volts DC
 Delay See www.bluesea.com
 CE marked

▶ See page 29 for ABYC Interrupt Rating Requirements.



IP 7010 Panel Mount



IP 7110 Surface Mount

Panel Mount		
PN	Amperage	Weight Lb (Kg)
7008	25A	0.24 (0.11)
7009	30A	0.24 (0.11)
7010	35A	0.24 (0.11)
7005	40A	0.24 (0.11)
7000	50A	0.24 (0.11)
7011	60A	0.24 (0.11)
7012	70A	0.24 (0.11)

Panel Mount		
PN	Amperage	Weight Lb (Kg)
7014	80A	0.24 (0.11)
7006	90A	0.24 (0.11)
7002	100A	0.24 (0.11)
7007	110A	0.24 (0.11)
7013	120A	0.24 (0.11)
7015	135A	0.24 (0.11)
7004	150A	0.24 (0.11)

Surface Mount		
PN	Amperage	Weight Lb (Kg)
7108	25A	0.30 (0.14)
7109	30A	0.30 (0.14)
7110	35A	0.30 (0.14)
7105	40A	0.30 (0.14)
7100	50A	0.30 (0.14)
7111	60A	0.30 (0.14)
7112	70A	0.30 (0.14)

Surface Mount		
PN	Amperage	Weight Lb (Kg)
7114	80A	0.30 (0.14)
7106	90A	0.30 (0.14)
7102	100A	0.30 (0.14)
7107	110A	0.30 (0.14)
7113	120A	0.30 (0.14)
7115	135A	0.30 (0.14)
7104	150A	0.30 (0.14)

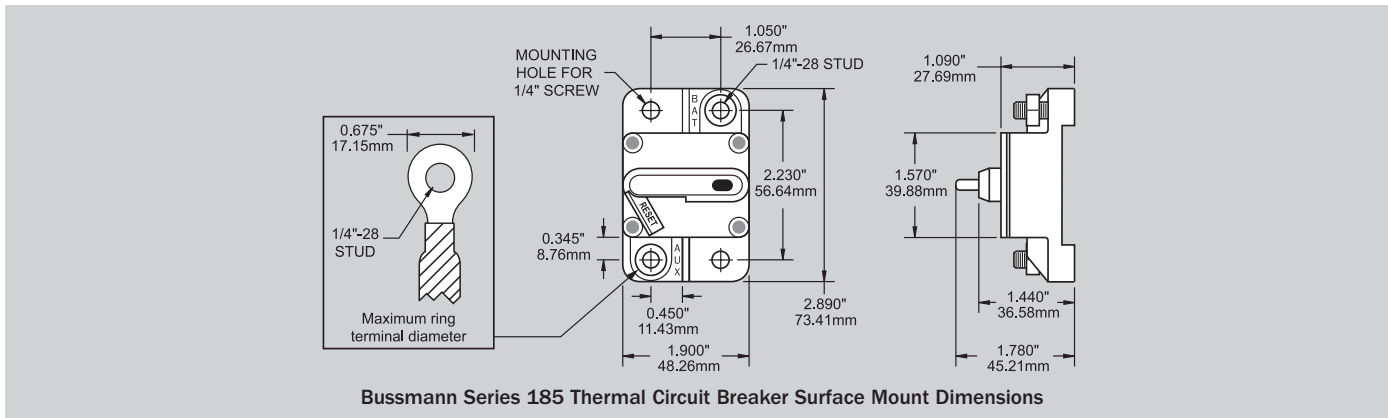

Bussmann Series 185 Thermal Circuit Breaker Surface Mount Dimensions

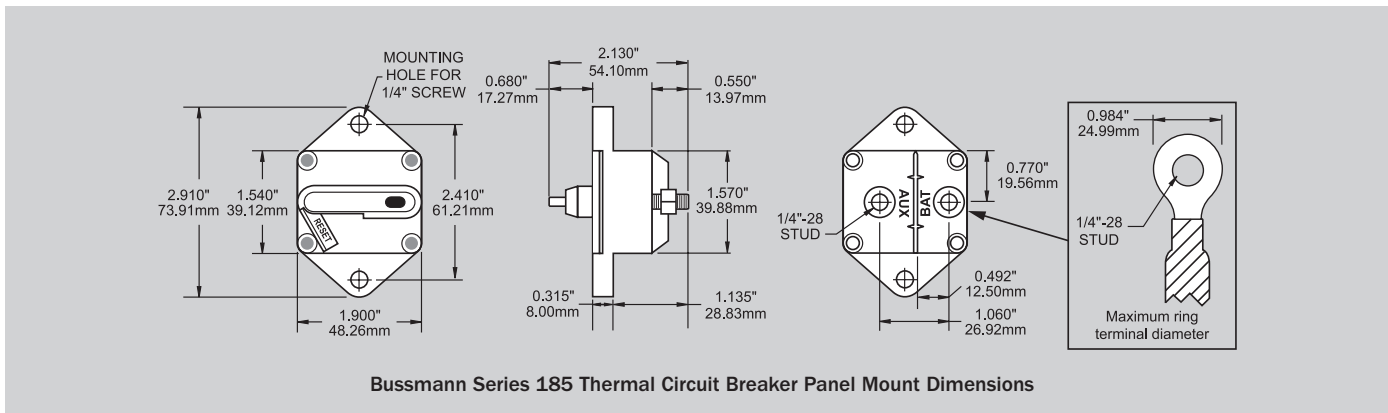

Bussmann Series 185 Thermal Circuit Breaker Panel Mount Dimensions

IP IGNITION PROTECTED

Bussmann Series 185 Circuit Breaker Mounting Options

- Used with Bussmann Series 185 Panel Mount Circuit Breakers
- 7199 Heavy 1/8" aluminum 5052 Alloy
- 7199 Two-part polyurethane slate gray finish
- 7198 Self trimming molded rubber bezel

PN	Description	Height in" (mm)	Width in" (mm)	Weight Lb (Kg)
7198	Trim Bezel	3.34 (84.71)	2.44 (61.90)	0.04 (0.02)
7199	Mounting Panel	4.00 (101.60)	3.00 (76.20)	0.12 (0.05)

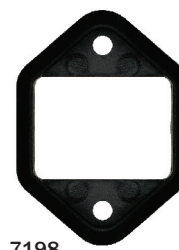

7198

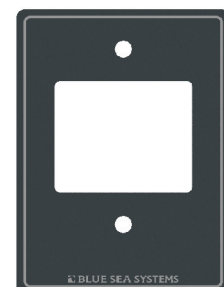

7199

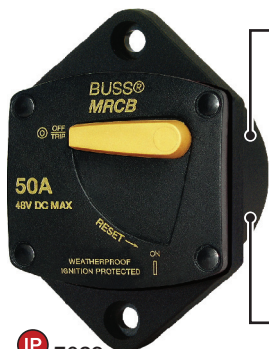

IP 7039
Panel Mount

Self-trimming case eliminates need for mounting panels or trim bezels

Round case for easy installation with standard sized hole saw



IP 7139
Surface Mount

Robust 5/16" terminals provide high torque connections

Large clearance around terminal stud accepts heavy gauge wire lugs

Bussmann Series 187 MRCB Marine Rated Circuit Breakers

- Combines switching and circuit protection into a single device
- Clear, single lever operation
- "Trip Free" design cannot be held "ON" during fault current condition
- Vaporproof
- Weatherproof
- Recessed mounting holes for clean appearance
- Large clearance around terminal studs accept heavy gauge wire lugs
- Robust 5/16" M8 terminals provide high torque connections
- Large lever with vertical/horizontal orientation provides indication of trip status
- Ignition protected - Safe for installation aboard gasoline powered boats

Specifications

Circuit Breaker Class	Type III - Switchable/Manual Reset - Trip Free
Type	Thermally Responsive Bi-Metal Blade
Case Material	Thermoset Polyester
Available Amperage	25-150 Amperes
Voltage Rating	48 Volts DC Maximum
Delay	See www.blueseas.com
Interrupt Rating:	5,000 Amperes@12 Volts DC 3,000 Amperes@24 Volts DC 1,500 Amperes@42 Volts DC

Agency Specifications

- All components meet SAE J1171 external ignition protection requirements

CE marked

▶ See page 29 for ABYC Interrupt Rating Requirements.

Panel Mount		
PN	Amperage	Weight Lb (Kg)
7035	25A	0.50 (0.23)
7036	30A	0.50 (0.23)
7037	35A	0.50 (0.23)
7038	40A	0.50 (0.23)
7039	50A	0.50 (0.23)
7040	60A	0.50 (0.23)
7041	70A	0.50 (0.23)
7042	80A	0.50 (0.23)
7043	90A	0.50 (0.23)
7044	100A	0.50 (0.23)
7045	110A	0.50 (0.23)
7046	120A	0.50 (0.23)
7047	135A	0.50 (0.23)
7048	150A	0.50 (0.23)

Surface Mount		
PN	Amperage	Weight Lb (Kg)
7135	25A	0.58 (0.26)
7136	30A	0.58 (0.26)
7137	35A	0.58 (0.26)
7138	40A	0.58 (0.26)
7139	50A	0.58 (0.26)
7140	60A	0.58 (0.26)
7141	70A	0.58 (0.26)
7142	80A	0.58 (0.26)
7143	90A	0.58 (0.26)
7144	100A	0.58 (0.26)
7145	110A	0.58 (0.26)
7146	120A	0.58 (0.26)
7147	135A	0.58 (0.26)
7148	150A	0.58 (0.26)

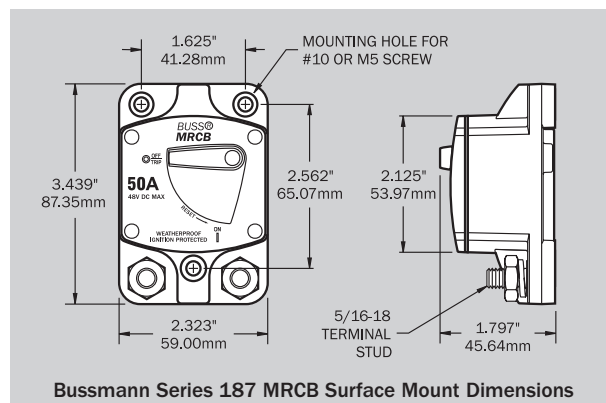
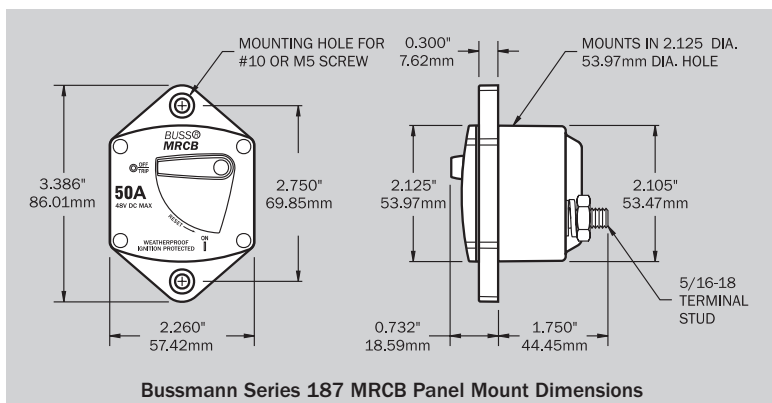

Important Information about the Bussmann 187 Series Circuit Breaker

The Cooper Bussmann 187 Series Thermal Circuit Breaker is based on the T-1 Thermal Circuit Breaker that was designed and developed by Blue Sea Systems engineers in 1999. In 2003 Cooper Bussmann purchased the T-1 tooling and patents from Blue Sea Systems. In 2005 Cooper Bussmann introduced the 187 Series Thermal Circuit Breaker based in part on the T-1 design. Using their long experience in thermal circuit breaker design, Cooper Bussmann enhanced the original T-1 internal mechanism & current path via several design changes. The 187 Series retains all the features that made the T-1 so popular – robust construction, easy mounting, large terminal studs and attractive styling.

Cooper Bussmann has certified that the 187 Series Thermal Circuit Breaker meets SAE J1171 for ignition protection and has a 5,000 Ampere interrupt capacity per ABYC E-11 at 12 Volts DC. The yellow handle and text of 187 Thermal Circuit Breaker clearly distinguish it from the T-1 Circuit Breaker's red handle. Please visit our website at www.blueseas.com for information on the T-1 recall initiated in 2003.

C-Series Toggle Circuit Breakers

5 to 300 Ampere DC range provides overcurrent protection previously only available in fuses for inverters, bow thrusters, and windlasses.

- Combines switching and circuit protection into a single device
- "Trip Free"- cannot be held closed after trip
- 7250I Ignition protected - Safe for installation aboard gasoline powered boats
- 7250I All components meet UL 1500 and ISO 8846 external ignition protection requirements

Specifications

Circuit Breaker Type	Magnetic
Body Material	Phenolic
Maximum Voltage	See Interrupt Ratings table below
Rated Switch Cycles	10,000 @ rated amperage and voltage
Delay	See www.blueseas.com

PN	Color	Poles	Amperage	Weight Lb (Kg)
7350	White	1*	5A	0.28 (0.13)
7351	White	1*	10A	0.28 (0.13)
7352	White	1*	15A	0.28 (0.13)
7353	White	1*	20A	0.28 (0.13)
7354	White	1*	25A	0.28 (0.13)
7355	White	1*	30A	0.28 (0.13)
7244	White	1*	50A	0.36 (0.17)
7246	White	1*	60A	0.36 (0.17)
7248	White	1*	80A	0.36 (0.17)
7250	White	1*	100A	0.36 (0.17)
7250I	Red	1*	100A	0.36 (0.17)
7267	White	2	150A	0.64 (0.31)
7268	White	2	175A	0.64 (0.31)
7269	White	2	200A	0.64 (0.31)
7270	White	3	250A	0.93 (0.46)
7271	White	3	300A	0.93 (0.46)

* Single pole circuit breakers are AC/DC rated

► See page 33 for Magnetic Circuit Breaker Mounting Panels.

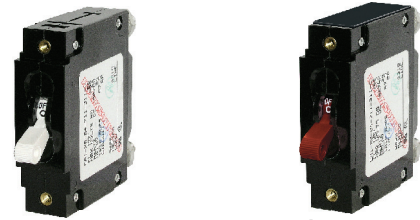

7250

IP 7250I

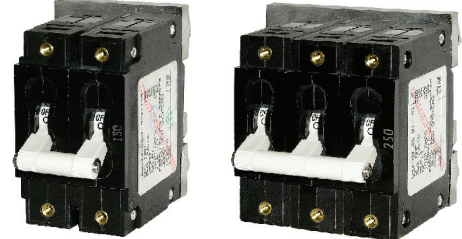

7267

7270

Interrupt Ratings (see ABYC Interrupt Rating Requirements page 29)

C-Series Circuit Breakers - Single Pole			
		UL 1077 - UL/CSA (US/Canada) ¹	EN60934 - TUV (Europe)
Voltage	Current	Interrupt Ratings	Interrupt Ratings
80V DC	5-100A	10,000A	5,000A
125V AC	5-100A	5,000A	5,000A
250V AC	5-100A	5,000A	5,000A

C-Series Circuit Breakers - 7250I Single Pole (Ignition Protected)			
		UL 1077 - UL/CSA (US/Canada) ¹	EN60934 - TUV (Europe)
Voltage	Current	Interrupt Ratings	Interrupt Ratings
48V DC	5-100A	5,000A	5,000A
125V AC	5-100A	1,500A	1,500A

C-Series Circuit Breakers - Double and Triple Pole			
Voltage	Current	Interrupt Ratings	Interrupt Ratings
65V DC	150-300A	5,000A ²	-

¹ UL Recognized
² No Agency Approvals

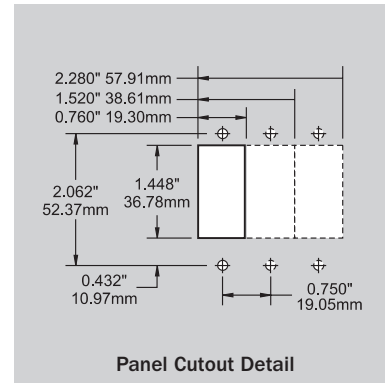
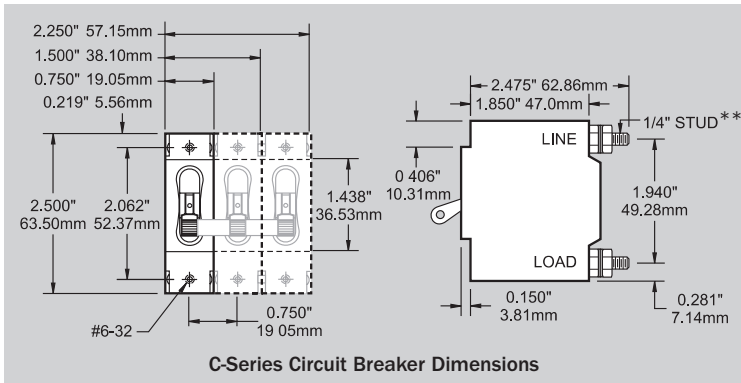

** Multiple pole versions have 5/16" terminal on bus



C-Series Magnetic Circuit Breaker Panels

- Heavy 1/8" aluminum 5052 Alloy
- Two-part polyurethane slate gray finish
- LED indicates power "ON"

Specifications

LED Amperage 5 Milliwatts

PN Panel	PN Circuit Breaker Installed	Poles	Amperage	Weight Lb (Kg)
7262	7267	2	150A	0.95 (0.45)
7263	7268	2	175A	0.95 (0.45)
7264	7269	2	200A	0.95 (0.45)
7265	7270	3	250A	1.21 (0.59)
7266	7271	3	300A	1.21 (0.59)



7266

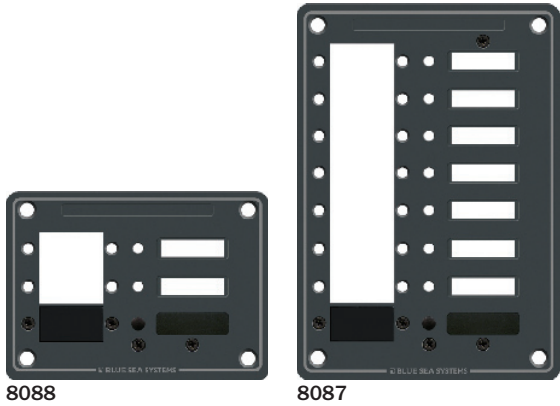

8088

8087

▶ See page 32 for C-Series Magnetic Circuit Breakers.

Magnetic Circuit Breaker Mounting Panels

- Designed for C-Series Magnetic Circuit Breakers
- Heavy 1/8" aluminum 5052 Alloy
- Two-part polyurethane slate gray finish
- Accepts standard Blue Sea Systems backlightable labels
- Accepts standard Blue Sea Systems "ON" indicating LEDs
- Industry standard height and width
- Optional panel plugs can be inserted to fill blank positions
- Optional Panel Plug Kit 8089 includes Circuit Breaker Mounting Screws, panel plug, LED plug, and blank label

PN	Description	Width in" (mm)	Height in" (mm)	Weight Lb (Kg)
8087	8 Position	5.25 (133.35)	7.50 (190.50)	0.40 (0.18)
8088	3 Position	5.25 (133.35)	3.75 (95.25)	0.28 (0.13)
8089	Panel Plug Kit	-	-	0.10 (0.04)



7450



7475



7477

AIRPAX®

Available January, 2006

Large Case 2.5" Rocker Circuit Breakers NEW PRODUCT

- Color actuator indicates "OFF" position
- "Trip Free" design cannot be held "ON" during fault current condition
- Flat actuator protects against accidental switching

Specifications

Circuit Breaker Type	Magnetic Hydraulic - Trip free
Maximum Amperage	See table below
Maximum Voltage	See table below
Rated Switch Cycles	10,000@rated amperage and voltage
Delay	See www.blueseasystems.com
Mounting screw	#6-32 SS - Recommended torque 6-8 in-lb
Terminal stud	1/4"-20 x 0.545" SS - Recommended torque 40-45 in-lb

CE marked

▶ See page 42 for more details

Interrupt Ratings (see ABYC Interrupt rating Requirements page 29)

IELBX Rocker Circuit Breakers - Single Pole			
		UL 1077 - UL/CSA (US/Canada) ¹	EN60934 - VDE (Europe)
Voltage	Current	Interrupt Ratings	Interrupt Ratings
65V DC	60-100A	7,500A	-
65V DC	60A	-	4,000A
125V AC	60-100A	3,000A	-
250V AC	60-100A	-	2,000A

CELBX Rocker Circuit Breakers - Double and Triple Pole			
		UL 489A - UL/CSA (US/Canada) ²	EN60934 - VDE (Europe)
Voltage	Current	Interrupt Ratings	Interrupt Ratings
80V DC	150-250A	10,000A	2,000A

¹ UL Recognized ² UL Listed

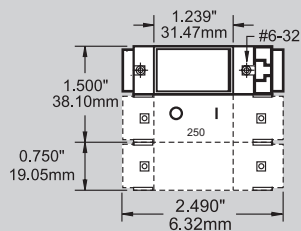

Large Case 2.5" Rocker Circuit Breaker Dimensions

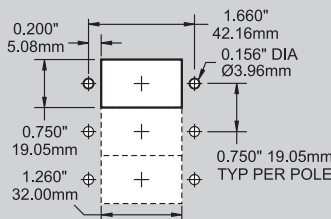

Rocker Panel Cutout Detail

PN	Actuator	Poles	Amperage
7450	Flat	1	60A
7451	Flat	1	80A
7452	Flat	1	100A
7475	Flat	2*	150A
7476	Flat	2*	200A
7477	Flat	3*	250A
4110	Panel Plug Kit	-	-

NEW PRODUCT

* Paralleled Poles

Update Available January, 2006

SEA Fuse Block **UPDATED PRODUCT**

Clear insulating cover - protects conductive components



Insert molded stud ensures secure fuse mounting

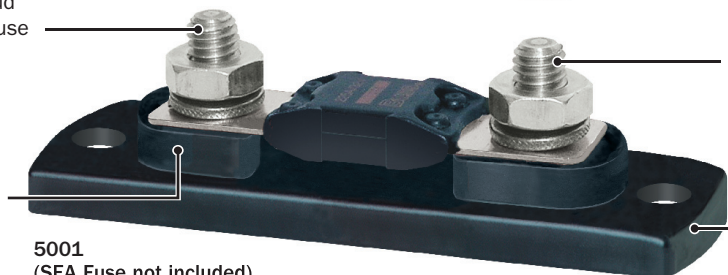

Stainless steel stud and fasteners prevent corrosion

180 degree access with cover on for 14-2/0 AWG wire

5001 (SEA Fuse not included)

UL 94-V0 base resists high heat

- The most economical system for 100-300 Ampere fusing
- Insulating cover satisfy ABYC/USCG requirements
- For use on systems up to 48 Volts DC
- Large stud terminals accept 5/16" or M8 ring terminals up to 2/0 AWG

Specifications

Base Material	Black Thermoplastic
Cover Material	Clear Thermoplastic
SEA Fuses available	100-300 Amperes DC
Maximum Amperage	300 Amperes DC
Maximum Voltage	48 Volts DC

PN	Description	Amperage	Weight Lb (Kg)
5000	Fuse Block without Cover	100-300A	0.17 (0.07)
5001	Fuse Block with Cover	100-300A	0.20 (0.09)

UPDATED PRODUCT

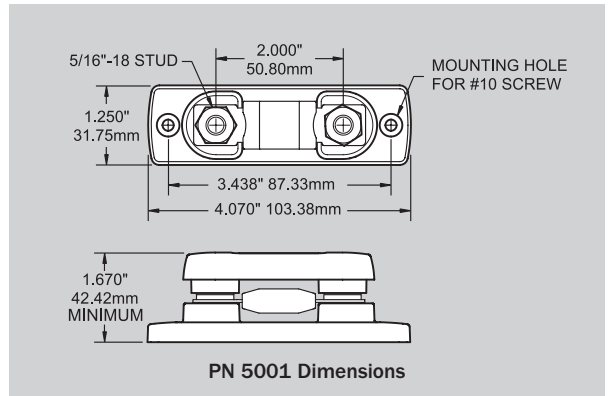

SEA Fuses

- Most economical fuse for 100-300 Ampere circuit protection

Specifications

Interrupt Capacity	2,000 Amperes DC
Maximum Voltage	48 Volts DC
Delay	See www.blueseasystems.com

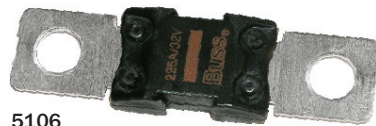

5106

PN	Amperage	Weight Lb (Kg)
5101	100A	0.06 (0.03)
5102	125A	0.06 (0.03)
5103	150A	0.06 (0.03)
5104	175A	0.06 (0.03)
5105	200A	0.06 (0.03)
5106	225A	0.06 (0.03)
5107	250A	0.06 (0.03)
5108	300A	0.06 (0.03)

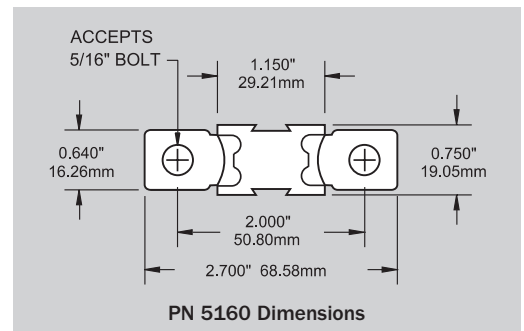

Update Available January, 2006

ANL Light Fuse Block UPDATED PRODUCT

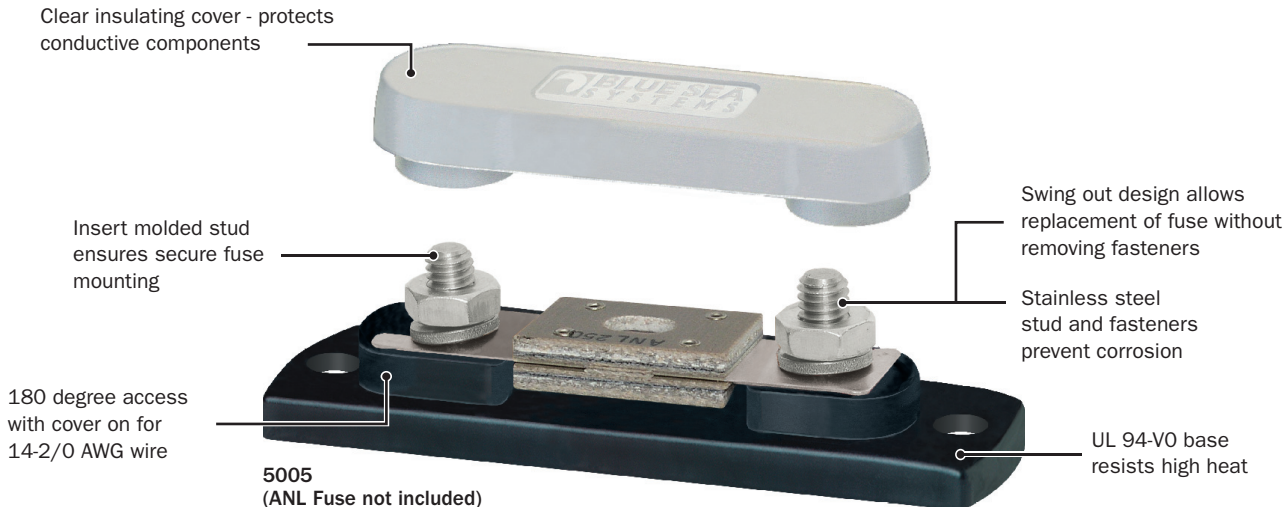

DC MAIN CIRCUIT PROTECTION

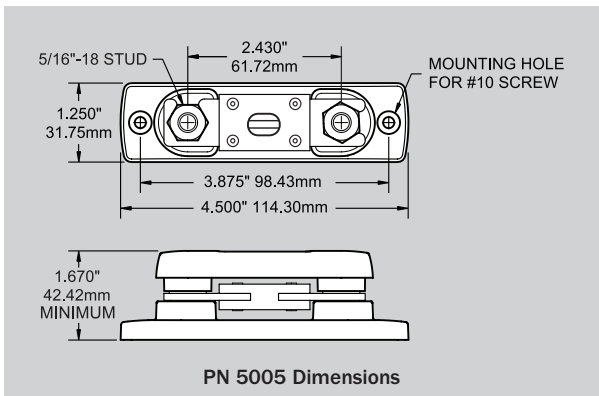

- Insulating cover satisfies ABYC/USCG requirements
- For use on systems up to 48 Volts DC
- Large 5/16" M8 studs accept 5/16" or M8 ring terminals up to 14-2/0 AWG

Specifications

Base Material	Black Thermoplastic
Cover Material	Clear Thermoplastic
Maximum Amperage	300 Amperes DC
Maximum Voltage	48 Volts DC

PN	Description	Amperage	Weight Lb (Kg)
5004	Fuse Block without Cover	35-300A	0.18 (0.08)
5005	Fuse Block with Cover	35-300A	0.21 (0.09)

UPDATED PRODUCT

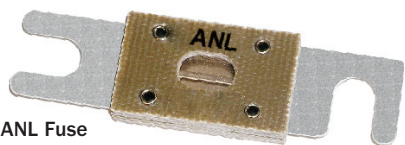

35-300 Ampere ANL Fuses

- Ignition protected (conforming to SAE J1171)
- Safe for installation aboard gasoline powered boats (35-300 Amperes only)
- Silver-plated connector blades for corrosion resistance
- Visible indication of blown fuse condition
- 6,000 Ampere Interrupt Capacity (AIC) satisfies ABYC requirements for main DC circuit protection on large battery banks

Specifications

Interrupt Capacity	6,000 Amperes DC
Maximum Voltage	48 Volts DC
Delay	See www.blueseas.com

Agency Specifications

- 35-500 Ampere Fuses meet the requirements of ISO 8846, SAE J1171, ABYC, USCG Title 33 CFR 183.410(a) and UL 1500

▶ See page 36 for high amperage ANL Fuses.

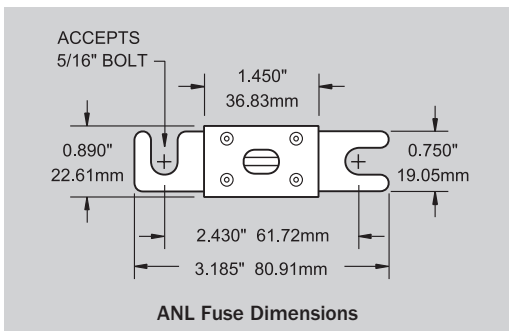

PN	Amperage	Weight Lb (Kg)	PN	Amperage	Weight Lb (Kg)
5164	35A	0.05 (0.02)	5127	150A	0.06 (0.03)
5165	40A	0.05 (0.02)	5128	175A	0.06 (0.03)
5122	50A	0.05 (0.02)	5129	200A	0.06 (0.03)
5123	60A	0.05 (0.02)	5130	225A	0.06 (0.03)
5124	80A	0.05 (0.02)	5131	250A	0.07 (0.03)
5125	100A	0.05 (0.02)	5132	275A	0.07 (0.03)
5126	130A	0.05 (0.02)	5133	300A	0.07 (0.03)



ANL Fuse Block

5003 Features

- 750 Ampere rating achieved with large heat dissipating tin-plated copper mounting blocks
- Clear insulating cover satisfies ABYC/USCG requirements
- For use on systems up to 48 Volts DC
- Large terminals accept 5/16" or M8 ring terminals up to 4/0 AWG

Specifications

Base Material	Black Reinforced Polycarbonate
Cover Material	Clear Reinforced Polycarbonate
Maximum Amperage	750 Amperes DC
Maximum Voltage	48 Volts DC
Fuse Mounting Blocks	Tin-Plated Copper

PN	Amperage	Weight Lb (Kg)
5003	35-750A	1.55 (0.70)

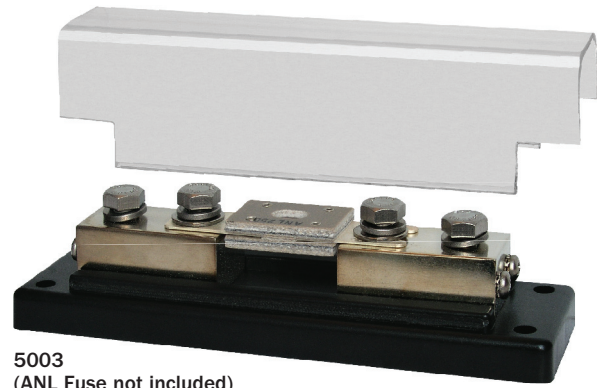

5003
(ANL Fuse not included)

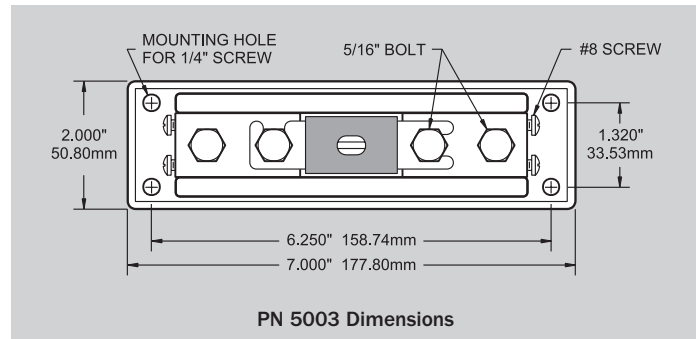

DC MAIN CIRCUIT PROTECTION

35-750 Ampere ANL Fuses

- Ignition protected (conforming to SAE J1171)
 - Safe for installation aboard gasoline powered boats (35-500 Amperes only)
- Silver-plated connector blades for corrosion resistance
- Visible indication of blown condition
- 6,000 Ampere Interrupt Capacity (AIC) satisfies ABYC requirements for main DC circuit protection on large battery banks

Specifications

Interrupt Capacity	6,000 Amperes DC
Maximum Voltage	48 Volts DC
Delay	See www.blueseas.com

Agency Specifications

- **35-500 Ampere Fuses** meet the requirements of ISO 8846, SAE J1171, ABYC, USCG Title 33 CFR 183.410(a) and UL 1500

PN	IP	Amperage	Weight Lb (Kg)
5164	IP	35A	0.05 (0.02)
5165	IP	40A	0.05 (0.02)
5122	IP	50A	0.05 (0.02)
5123	IP	60A	0.05 (0.02)
5124	IP	80A	0.05 (0.02)
5125	IP	100A	0.05 (0.02)
5126	IP	130A	0.05 (0.02)
5127	IP	150A	0.06 (0.03)
5128	IP	175A	0.06 (0.03)
5129	IP	200A	0.06 (0.03)
5130	IP	225A	0.06 (0.03)
5131	IP	250A	0.07 (0.03)
5132	IP	275A	0.07 (0.03)
5133	IP	300A	0.07 (0.03)
5134	IP	325A	0.07 (0.03)
5135	IP	350A	0.07 (0.03)
5136	IP	400A	0.08 (0.04)
5137	IP	500A	0.08 (0.04)
5161	-	600A	0.08 (0.04)
5162	-	675A	0.08 (0.04)
5163	-	750A	0.08 (0.04)

IP IGNITION PROTECTED

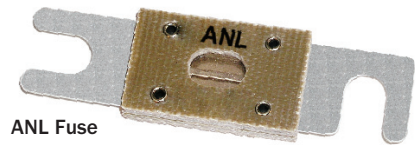

ANL Fuse

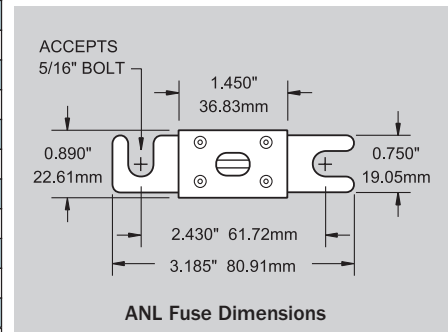

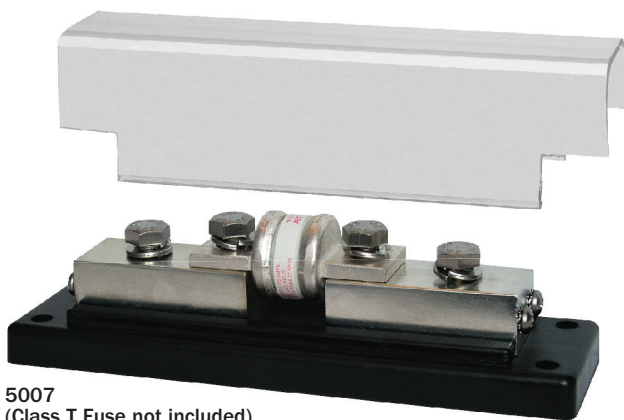

5007
(Class T Fuse not included)

Class T Fuse Blocks

The fuse system recommended by most inverter manufacturers for high speed response to short circuits.

- Clear insulating cover, satisfies ABYC/USCG requirements
- For use on systems up to 160 Volts DC
- Large stud terminals (3/8" on 5002, 5/16" on 5007) accept ring terminals for wire up to 4/0 AWG
- Large heat dissipating tin-plated copper mounting blocks
- Two #8 accessory terminals located on each end

Specifications

Base Material	Black Reinforced Polycarbonate
Cover Material	Clear Reinforced Polycarbonate
Class T Fuses available	110-400 Amperes DC
Maximum Amperage	400 Amperes DC
Maximum Voltage	160 Volts DC
Fuse Mounting Blocks	Tin-Plated Copper

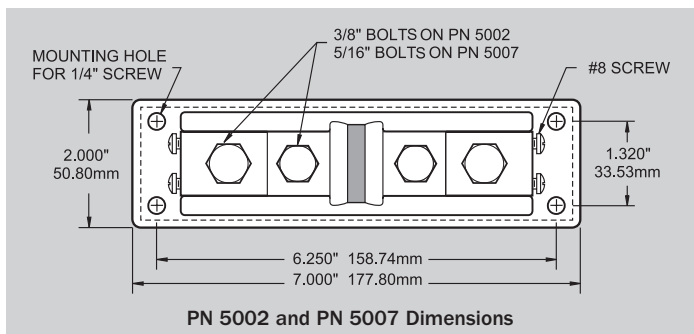

PN	Amperage	Weight Lb (Kg)	Accepts Fuse PN
5007	110-200A	1.40 (0.64)	5112, 5113, 5114, 5115, 5116
5002	225-400A	1.55 (0.70)	5117, 5118, 5119, 5120, 5121

Class T Fuses

- Extremely fast short-circuit response
- 20,000 Ampere Interrupt Capacity (AIC)
- UL listed to standard 248-15
- DC tested to UL standard 198L

Specifications

Interrupt Capacity	20,000 Amperes DC
Maximum Voltage	160 Volts DC
Delay	See www.bluesea.com



5112

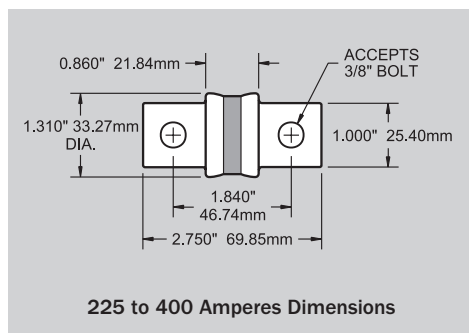
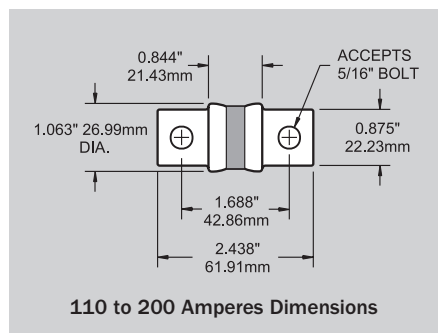

PN	Amperage	Weight Lb (Kg)
5112	110A	0.19 (0.09)
5113	125A	0.19 (0.09)
5114	150A	0.19 (0.09)
5115	175A	0.19 (0.09)
5116	200A	0.19 (0.09)
5117	225A	0.29 (0.13)
5118	250A	0.29 (0.13)
5119	300A	0.29 (0.13)
5120	350A	0.29 (0.13)
5121	400A	0.29 (0.13)

ANL Fuses vs. Class T Fuses

What is the difference between an ANL and a Class T fuse?

These two fuses are the most common high amperage fuses used in marine applications and there are significant differences between the two:

ANL Fuse Advantages:

- Lower cost than Class T fuses
- Available in a wider amperage range (35A - 750A) than Class T Fuses
- Single mounting hole dimension allows all ANL Fuses to be used with the same fuse block
- Fusible link window gives visual indication of fuse being blown
- Ignition protected - Safe for installation aboard gasoline powered boats



Class T Fuse Advantages:

- The only UL 248-15L listed fuse commonly available in the marine industry
- Fast response to short circuits protects high amperage electronic equipment such as inverters



The portion of the DC Distribution System that conducts power from the end of the DC Main Power Distribution System (the end of the wire protected by a DC Main circuit protection device) to the load devices at the end of the circuit. Typically, the DC Branch Power Distribution System carries lower DC current, roughly those currents below 50 Amperes.

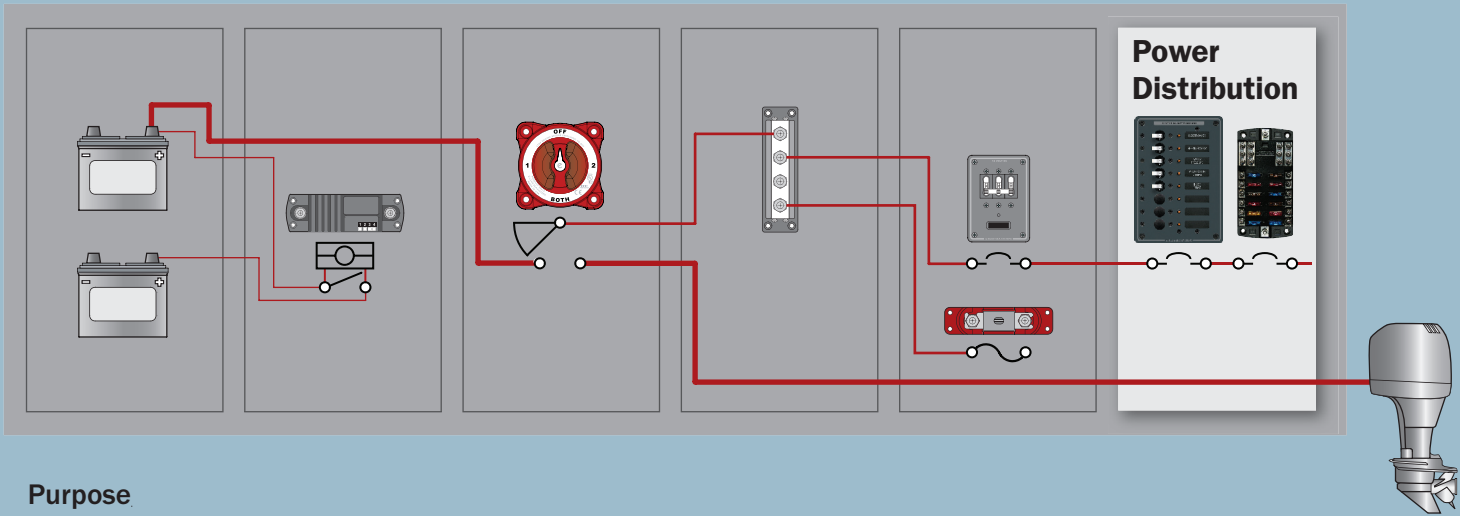

Purpose

The distribution of high amperages from a single cable into lower amperages with multiple wires, circuit protection, and switching. These three functions may be consolidated into a single device as in the case of a circuit breaker distribution panel or each function may reside as separate devices as shown in the system configuration diagrams below.

Configurations

- 1) A switch panel with fuses or circuit breakers for circuit protection is common for small distribution applications.
 - a. Water resistant WeatherDeck™ Switch Panels with integral ATO fuse circuit protection. (Figure 1)
 - b. Water resistant Contura Switch Panels with integral AGC fuse circuit protection. (Figure 2)
 - c. Water resistant WeatherDeck™ Switch Panel with integral Push Button Circuit Breaker circuit protection. (Figure 3)

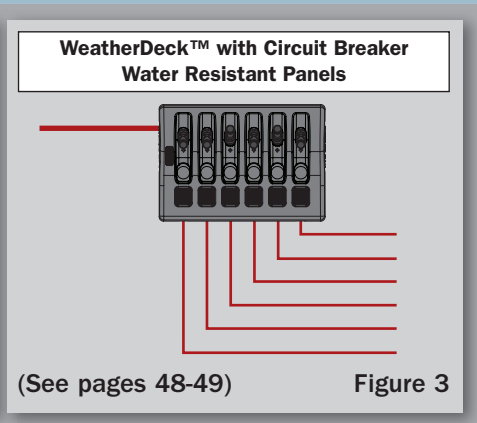
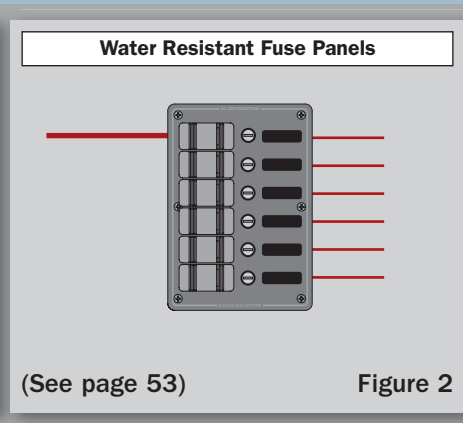
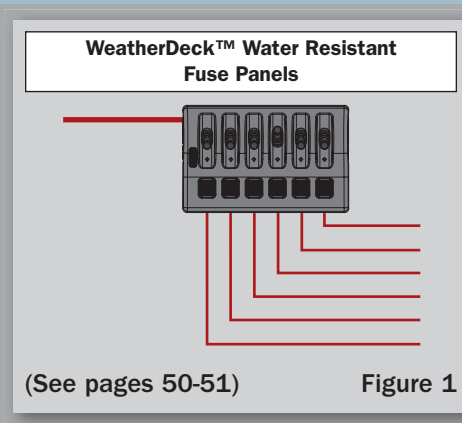

- 2) A panel with switches only combined with separate circuit protection which can be mounted remotely.
 - a. ST Blade Fuse Block combined with a Contura Switch Only Panel. (Figure 4)

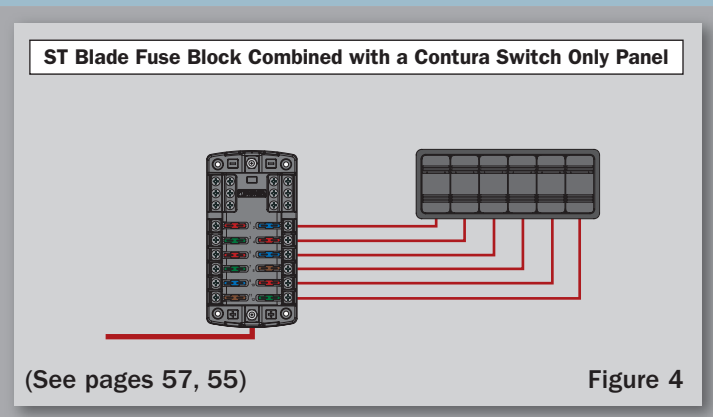

- 3) A circuit breaker distribution panel with or without a sub-panel.
 - a. A distribution panel with circuit breakers combining switching and circuit protection. (Figure 5)
 - b. A distribution panel with circuit breakers combined with a fuse block for load switched electronics. (Figure 6)
 - c. A distribution panel with circuit breakers combined with a remote switch and fuse/circuit breaker panel. (Figure 7)

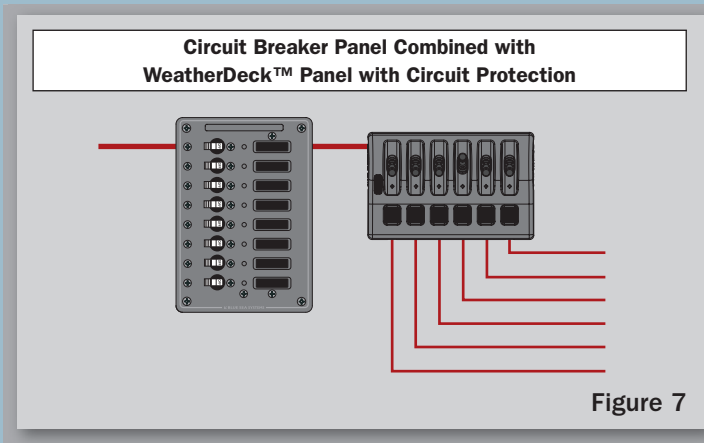
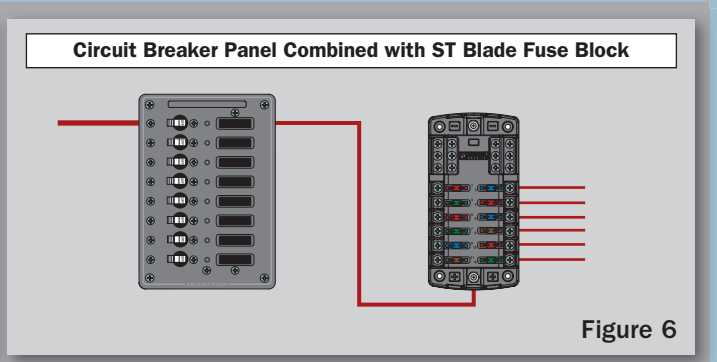
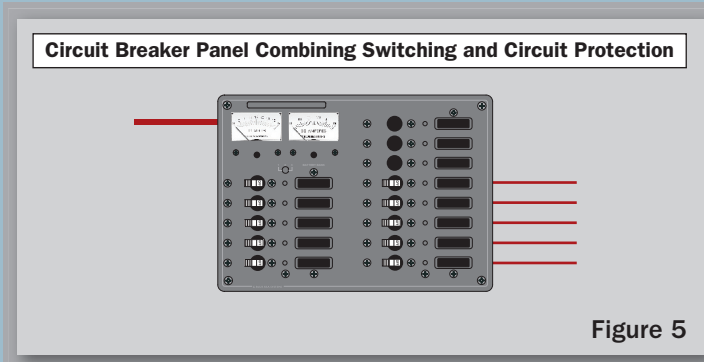

- 4) A busbar combined with three MAXI™ Fuse Blocks for higher amperage (30-80 Amperes DC) loads (Figure 8)

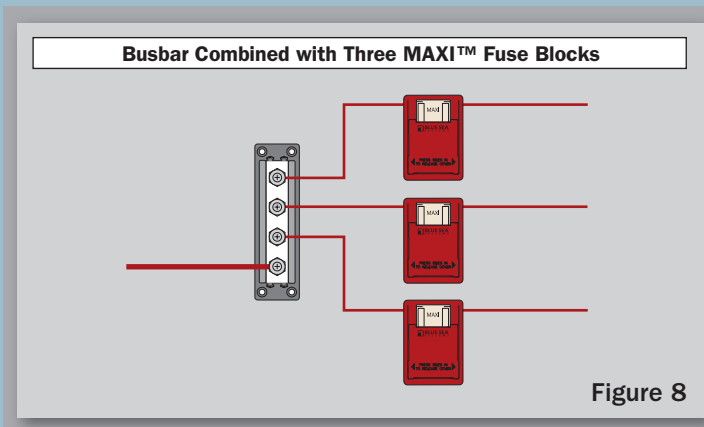

- 5) ST Blade Fuse Block (Figure 9)

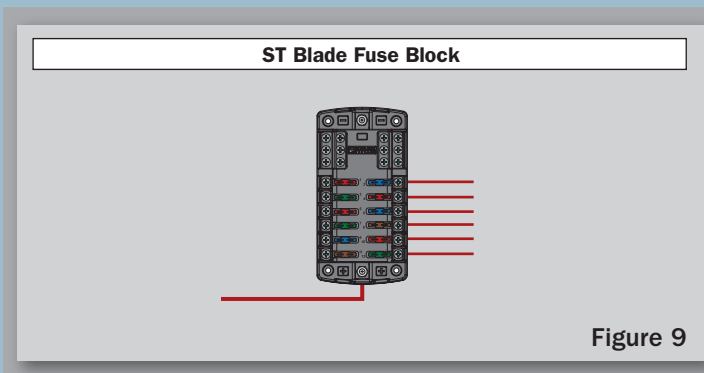

Push Button Reset Only Circuit Breakers

- Lowest cost circuit breaker available
- Incorporated into Blue Sea Systems Water Resistant Circuit Breaker Panels (see page 48-49) and Battery Management Panels (see page 20-21,52)
- Compact design enables high density circuit protection configurations
- Push to reset operation
- "Trip Free" design cannot be held "ON" during fault current condition
- Ignition protected - Safe for installation aboard gasoline powered boats

Specifications

Circuit Breaker Type Thermal reset only - Trip free
 Maximum Voltage 28 Volts DC
 Delay See www.blueseasystems.com
 Weight 0.24Lb (0.11Kg)

CE marked

Agency Specifications

- All components meet UL 1500 and ISO 8846 external ignition protection requirements

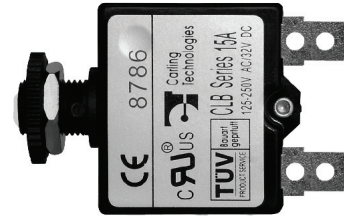

IP 7056

Interrupt Ratings (see ABYC Interrupt rating requirements page 29)

CLB Thermal Circuit Breaker		
UL 1077 - UL/CUL (US/Canada) ¹		
Voltage	Current	Interrupt Ratings
28V DC	3-40A	2,500A

Note: AC ratings have been omitted. They do not meet minimum ABYC requirements.

¹ UL Recognized

PN	Amperage
7050	3A
7051	4A
7052	5A
7053	7A
7054	10A
7055	12A
7056	15A
7057	20A
7058	25A
7059	30A
7060	35A
7061	40A

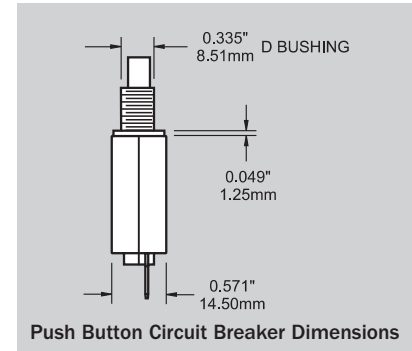
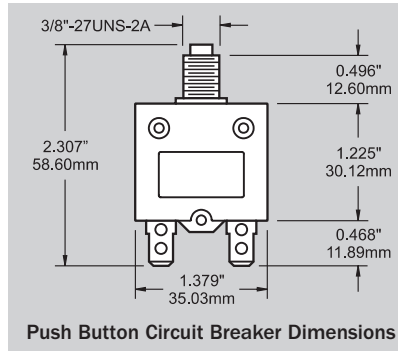
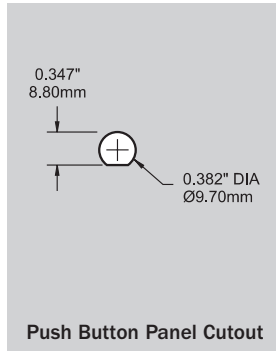

IP IGNITION PROTECTED

DC BRANCH POWER DISTRIBUTION AND CIRCUIT PROTECTION

Push Button Waterproof Boots

- Replaces standard mounting nut for mounting Push Button Thermal Circuit Breakers
- UV resistant material resists discoloration and cracking
- Protects Push Button Circuit Breaker in wet environments

Specifications

Case Material UV Resistant Silicone Rubber
 Thread Material Nickel-Plated Brass
 Thread 3/8"-27
 Weight 0.03Lb (0.02Kg)

PN	Color
4135	Clear
4136	White
4137	Black

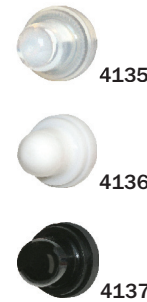

Push Button Circuit Breakers with waterproof boots are used in the Water Resistant Circuit Breaker Panels (see page 48-49, 52)

8272

8371

4376

Single Pole Toggle World Circuit Breakers

- Meets all American Boat and Yacht Council (ABYC) standards
- UL 1077 recognized, TUV certified, CE marked for Europe, and CSA certified for Canada
- The industry standard circuit breaker for Blue Sea Systems electrical panels
- Combines switching and circuit protection into a single device
- Single pole “Quick Trip” models are designed specifically for electronics protection
- “Trip Free” design cannot be held “ON” during fault current condition

Specifications

Circuit Breaker Type	Magnetic Hydraulic - Trip free
Maximum Amperage	50 Amperes
Maximum Voltage	277 Volts AC/65 Volts DC
Rated Switch Cycles	10,000@rated amperage and voltage
Trip Time Delay	See www.blueseasystems.com
Weight	0.17Lb (0.08Kg)
Mounting screw	#6-32
Terminal screw	#10-32 SS with external tooth lock washer
CE marked	



7200



7202

Interrupt Ratings (For ABYC Interrupt rating requirements, see page 29)

World Circuit Breakers - Single Pole			
Voltage	Current	UL 1077 - UL/CSA (US/Canada) ¹	EN60934 - TUV (Europe)
		Interrupt Ratings	Interrupt Ratings
65V DC	1-50A	7,500A	1,500A
120V AC	1-50A	3,000A	1,500A
250V AC	1-50A	3,000A	1,500A

¹ UL Recognized

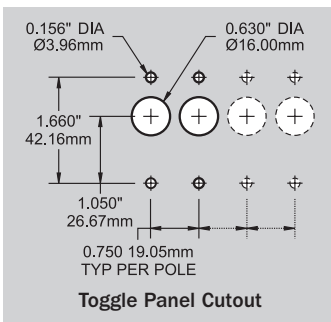
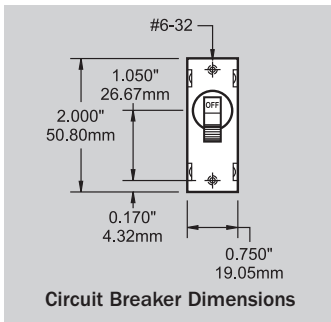

PN	Color	Amperage	Delay
7291	White	1A	Quick Trip
7292	White	2.5A	Quick Trip
7293	White	5A	Quick Trip
7200	Black	5A	Standard
7201	Red	5A	Standard
7202	White	5A	Standard
7347	Black	8A	Standard
7299	White	8A	Standard
7204	Black	10A	Standard
7205	Red	10A	Standard
7206	White	10A	Standard
7208	Black	15A	Standard
7209	Red	15A	Standard
7210	White	15A	Standard

PN	Color	Amperage	Delay
7212	Black	20A	Standard
7213	Red	20A	Standard
7214	White	20A	Standard
7216	Black	25A	Standard
7217	Red	25A	Standard
7218	White	25A	Standard
7220	Black	30A	Standard
7221	Red	30A	Standard
7222	White	30A	Standard
7224	Black	40A	Standard
7225	Red	40A	Standard
7226	White	40A	Standard
7228	Black	50A	Standard
7229	Red	50A	Standard
7230	White	50A	Standard

NEW PRODUCT

- ▶ For Double Pole AC World Circuit Breakers, see page 63 and 72
- ▶ For circuit breaker mounting panels, see page 87

DC BRANCH POWER DISTRIBUTION AND CIRCUIT PROTECTION

Rocker Style Magnetic Circuit Breakers

Rocker Circuit Breakers offer several advantages over the traditional toggle style circuit breakers long used in the marine industry. The Rocker Circuit Breaker body and mechanical components are identical to toggle magnetic circuit breakers; it is only the actuation mechanism that is different.

Rocker Circuit Breakers have five distinct advantages over traditional toggle circuit breakers:

- 1) They offer a contemporary styling more appropriate for today's boats.
- 2) Rocker Circuit Breakers "color indicate" their ON/OFF status for rapid identification of circuit breaker status.
- 3) All Rocker Circuit Breakers are resistant to accidental switching and the Flat and Slot Reset styles are completely immune to accidental switching.
- 4) Within their standard rectangular mounting aperture both small case 2" circuit breakers up to 50 Amperes and large case 2.5" circuit breakers up to 250 Amperes can be used in the same panel.
- 5) Rocker Circuit Breakers are available in a wide variety of actuator styles, as exemplified by the three actuator styles shown below:

Raised Rocker - Small Case 2" Rocker Circuit Breaker (see pages 43, 64, and 73)

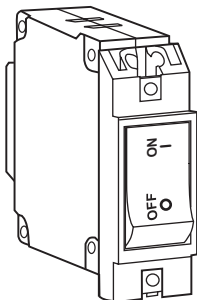

Features

- **Good** resistance to accidental switching
- Better than traditional toggle circuit breakers
- Red color indicates ON condition
- International ON/OFF symbol

Flat Rocker - Small Case 2" and Large Case 2.5" Rocker Circuit Breakers (see pages 33, 43, and 73)

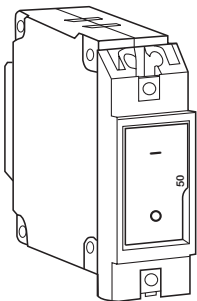

Features

- **Better** resistance to accidental switching
- White color indicates OFF condition
- Rocker actuator is flush in the ON position, eliminating risk of accidental switching
- International ON/OFF symbols support vertical or horizontal mounting

Slot Reset - Small Case 2" Rocker Circuit Breakers (see pages 43 and 73)

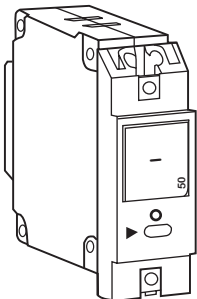

Features

- **Best** resistance to accidental switching
- White color indicates OFF condition
- Can only be turned OFF by inserting small screw driver into slot
- International ON/OFF symbols support vertical or horizontal mounting



7300

AIRPAX®

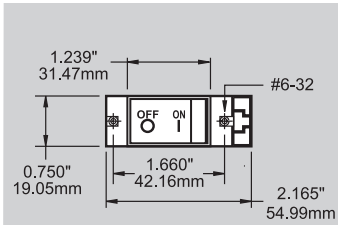

Single Pole Small Case 2" Rocker Circuit Breaker Dimensions

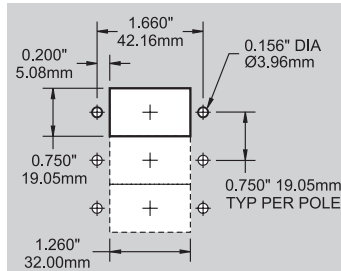

Rocker Panel Cutout

Interrupt Ratings (see ABYC Interrupt rating requirements page 29, 61)

Small Case Rocker Circuit Breakers - Single Pole			
		UL 1077 - UL/CSA (US/Canada) ¹	EN60934 - VDE (Europe)
Voltage	Current	Interrupt Ratings	Interrupt Ratings
65V DC	5-50A	-	2,000A
80V DC	5-30A	-	4,000A
80V DC	5-50A	7,500A	-
125V AC	5-50A	3,000A	-
240V AC	5-50A	2,000A	-
250V AC	5-30A	2,000A	2,000A
250V AC	5-50A	-	2,000A

¹ UL Recognized

Single Pole Small Case 2" Rocker Circuit Breakers

- Rocker actuator offers modern appearance to electrical distribution panels
- Dual color rocker gives clear visual indication of handle position
- "Trip Free" design cannot be held "ON" during fault current condition

Specifications

Circuit Breaker Type	Magnetic Hydraulic - Trip free
Case Material	Polyester
Maximum Amperage	See table below
Maximum Voltage	See table below
Rated Switch Cycles	10,000@rated amperage and voltage
Trip Time Delay	See www.blueseas.com
Weight	0.19Lb (0.09Kg)
Mounting screw	#6-32
Terminal screw	#10-32 SS with external tooth lock washer

CE marked

PN	Amperage
7300	5A
7301	8A
7302	10A
7303	15A
7304	20A
7305	25A
7306	30A
7307	40A
7308	50A

► For Double Pole AC Rocker Circuit Breakers, see pages 64 and 73

Flat



7408

Slot Reset



7433

AIRPAX®

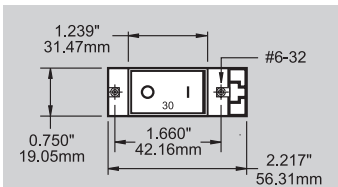

Single Pole Small Case 2" Rocker Circuit Breaker Dimensions

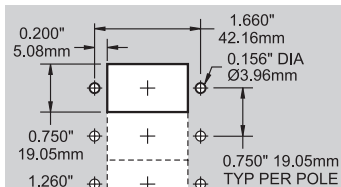

Rocker Panel Cutout

Interrupt Ratings (see ABYC Interrupt rating Requirements page 29)

Small Case IEGBX Rocker Circuit Breakers - Single Pole			
		UL 1077 - UL/CSA (US/Canada) ¹	EN60934 - VDE (Europe)
Voltage	Current	Interrupt Ratings	Interrupt Ratings
65V DC	5-50A	-	2,000A
80V DC	5-30A	-	4,000A
80V DC	5-50A	7,500A	-
125V AC	5-50A	3,000A	-
240V AC	5-50A	2,000A	-
250V AC	5-30A	2,000A	2,000A
250V AC	5-50A	-	2,000A

¹ UL Recognized

Available January, 2006

Single Pole Small Case 2" Rocker Circuit Breakers

NEW PRODUCT

- Color actuator indicates "OFF" position
- "Trip Free" design cannot be held "ON" during fault current condition
- 2 different styles available to protect accidental switching of 24 hour circuits

Specifications

Circuit Breaker Type	Magnetic Hydraulic - Trip free
Maximum Amperage	See table below
Maximum Voltage	See table below
Rated Switch Cycles	10,000@rated amperage and voltage
Delay	See www.blueseas.com
Mounting screw	#6-32 SS - Recommended torque 6-8 in-lb
Terminal screw	45° Angled #10-32 x 5/16 SS SEM external tooth lock washer
	- Recommended torque 14-15 in-lb

CE marked

► See page 42 for more details

PN	Actuator	Poles	Amperage	PN	Actuator	Poles	Amperage
7400	Flat	1	5A	7425	Slot Reset	1	5A
7401	Flat	1	8A	7426	Slot Reset	1	8A
7402	Flat	1	10A	7427	Slot Reset	1	10A
7403	Flat	1	15A	7428	Slot Reset	1	15A
7404	Flat	1	20A	7429	Slot Reset	1	20A
7405	Flat	1	25A	7430	Slot Reset	1	25A
7406	Flat	1	30A	7431	Slot Reset	1	30A
7407	Flat	1	40A	7432	Slot Reset	1	40A
7408	Flat	1	50A	7433	Slot Reset	1	50A

NEW PRODUCT

DC Rocker and Toggle Panels

Powerboat Reports choice for Electrical Distribution Panels*

Common Features

- MIL-C-5541C or equivalent immersion undercoating for lifetime corrosion resistance
 - DC panels with meters include toggle switch for monitoring up to 3 battery banks
 - DC panels are available in 12 or 24 Volt DC configuration except panels with analog meters*
 - All circuit label positions are backlit on standard panels - No kit required
 - "ON" indicating LEDs installed in all circuit positions
 - Countersunk mounting holes throughout
 - Two-part polyurethane slate gray finish
 - Heavy 1/8" aluminum 5052 alloy
 - Industry standard height and width
- * Panels with analog meters are upgradeable to 24 Volts DC

Tin-Plated Copper bussing for high conductivity



DC BRANCH POWER DISTRIBUTION AND CIRCUIT PROTECTION

DC Toggle style Circuit Breaker Panels are now available with black World Magnetic Circuit Breakers (see pages 46-47)



A wide range of DC digital and analog meters are available (see pages 95-101)

Industry standard, toggle style, World Magnetic Circuit Breakers available in white or black (see pages 41, 63, 72)

Rocker style Magnetic Circuit Breakers offer modern styling and improved resistance to accidental switching (see pages 43, 64, 73)



* "Blue Sea Systems' excellent warranty, intuitive labeling, and bright night lighting, is our choice for an accessory DC panel." - Powerboat Reports, June 2005

DC Rocker Circuit Breaker Panels

Common Features

- All positive, negative and grounding buses installed, fully pre-wired
- Includes set of 30 common backlightable DC labels (see page 90)
- Label backlighting pre-installed
- All LEDs installed
- Configure for 12 or 24 Volt DC distribution with supplied labels
- Panel Main Bus 100 Amperes
- Detailed installation instructions and cutout template included
- Over 500 individual labels to choose from (see pages 91-94)

13 Position



8679

10 Position



8680

5 Position



8678

8 Position



8676

6 Position



8677

3 Position



8675

PN	Description	Meter Type/PN	Meter Page	Width in" (mm)	Height in" (mm)	Weight Lb (Kg)	Installed Single Pole Circuit Breakers
							15A
8675	3 Position	-	-	5.25 (133.35)	3.75 (95.25)	1.12 (0.61)	3
8678	5 Position	Digital/8248	98	5.25 (133.35)	7.50 (190.50)	3.45 (1.56)	5
8677	6 Position	-	-	10.50 (266.70)	3.75 (95.25)	2.20 (1.00)	6
8676	8 Position	-	-	5.25 (133.35)	7.50 (190.50)	1.84 (0.83)	5
8680	10 Position	Digital/8248	98	5.25 (133.35)	11.25 (285.75)	4.21 (1.92)	7
8679	13 Position	Digital/8248	98	10.50 (266.70)	7.50 (190.50)	5.15 (2.34)	10

DC BRANCH POWER DISTRIBUTION AND CIRCUIT PROTECTION



Squalicum Harbor, Bellingham Bay, and San Juan Islands

DC Toggle Circuit Breaker Panels

Common Features

- All positive, negative and grounding buses installed, fully pre-wired
- Includes set of 30 common backlightable DC labels (see page 90)
- Label backlighting pre-installed
- All LEDs installed
- Detailed installation instructions and cutout template included
- Over 500 individual labels to choose from (see pages 91-94)
- Maximum panel amperage - 100 Amperes

Main + 35 Positions



8382 3382

24 Position



8264 3264

12 Position



8375 3375

Main + 32 Positions

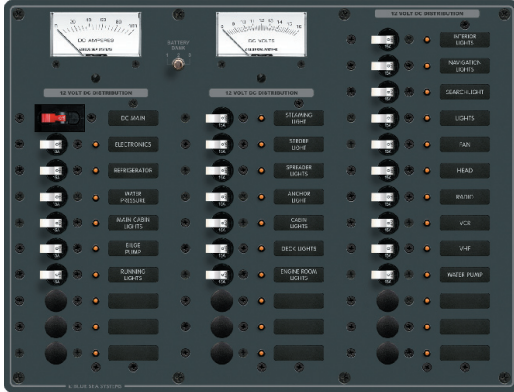

8381 3381

13 Position



8403 3403

Main + 20 Positions



8379 3379

13 Position



8068 3068

18 Position



8378 3378

16 Position



8377 3377

DC BRANCH POWER DISTRIBUTION AND CIRCUIT PROTECTION

Main + 22 Positions



8380 3380

10 Position

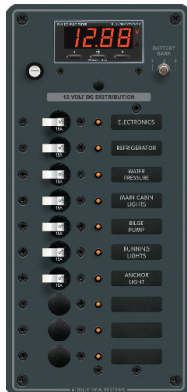

8402 3402

10 Position



8082 3082

13 Position



8376 3376

8 Position



8385 3385

5 Position



8401 3401

5 Position



8081 3081

8 Position



8023 3023

3 Position



8025 3025

6 Position



8096 3096

DC Main Circuit Breaker Panels

PN	PN	Description	Meter Type/PN	Meter Page	Voltage	Width in" (mm)	Height in" (mm)	Weight Lb (Kg)	Installed C-Series Main Circuit Breaker	Installed Single Pole Circuit Breaker
									100A	15A
8379	3379	Main + 20 Positions	Digital/8248	98	12/24V DC	14.75 (374.65)	7.50 (190.50)	7.20 (3.27)	1	14
8380	3380	Main + 22 Positions	Analog/8028, 8250	101	12V DC	10.50 (266.70)	11.25 (285.75)	6.10 (2.76)	1	16
8381	3381	Main + 32 Positions	Analog/8003, 8017	101	12V DC	14.75 (374.65)	11.25 (285.75)	8.60 (3.89)	1	23
8382	3382	Main + 35 Positions	Digital/8248	98	12/24V DC	14.75 (374.65)	11.25 (285.75)	10.80 (4.92)	1	26

DC Branch Circuit Breaker Panels

PN	PN	Description	Meter Type/PN	Meter Page	Voltage	Width in" (mm)	Height in" (mm)	Weight Lb (Kg)	Installed C-Series Main Circuit Breaker	Installed Single Pole Circuit Breaker
									100A	15A
8025	3025	3 Position	-	-	12/24V DC	5.25 (133.35)	3.75 (95.25)	1.12 (0.61)	-	3
8401	3401	5 Position	Digital/8248	98	12/24V DC	5.25 (133.35)	7.50 (190.50)	3.45 (1.56)	-	5
8081	3081	5 Position	Analog/8028, 8041	101	12V DC	5.25 (133.35)	7.50 (190.50)	4.06 (1.84)	-	5
8096	3096	6 Position	-	-	12/24V DC	10.50 (266.70)	3.75 (95.25)	2.20 (1.00)	-	6
8023	3023	8 Position	-	-	12/24V DC	5.25 (133.35)	7.50 (190.50)	1.84 (0.83)	-	5
8385	3385	8 Position	-	-	12/24V DC	10.50 (266.70)	4.50 (114.30)	1.95 (0.88)	-	6
8402	3402	10 Position	Digital/8248	98	12/24V DC	5.25 (133.35)	11.25 (285.75)	4.21 (1.91)	-	7
8082	3082	10 Position	Analog/8028, 8041	101	12V DC	5.25 (133.35)	11.25 (285.75)	4.06 (1.84)	-	7
8375	3375	12 Position	-	-	12/24V DC	14.75 (374.65)	4.50 (114.30)	3.10 (1.41)	-	10
8376	3376	13 Position	-	-	12/24V DC	5.25 (133.35)	11.25 (285.75)	2.76 (1.25)	-	10
8403	3403	13 Position	Digital/8248	98	12/24V DC	10.50 (266.70)	7.50 (190.50)	5.15 (2.34)	-	10
8068	3068	13 Position	Analog/8028, 8041	101	12V DC	10.50 (266.70)	7.50 (190.50)	4.06 (1.84)	-	10
8377	3377	16 Position	-	-	12/24V DC	10.50 (266.70)	7.50 (190.50)	3.68 (1.67)	-	10
8378	3378	18 Position	Analog/8003, 8017	101	12V DC	14.75 (374.65)	7.50 (190.50)	5.70 (2.59)	-	15
8264	3264	24 Position	-	-	12/24V DC	14.75 (374.65)	7.50 (190.50)	5.12 (2.32)	-	15

DC BRANCH POWER DISTRIBUTION AND CIRCUIT PROTECTION

Available January, 2006

WeatherDeck™ Water Resistant Circuit Breaker Panels NEW PRODUCT

Water resistant panel front withstands rain, sea spray, and hose spray washdown

- Designed for flybridge and open cockpit applications
- Constructed from corrosion resistant materials
- Independent label backlighting circuit for remote switching and dimming
- Compatible with all Blue Sea Systems Digital Dimmers (see page 104)
- UV stabilized and weather resistant faceplate
- Rated IP67 - "Temporary Immersion"
- Rugged UV stabilized waterproof boots protect switches and circuit breakers
- Each panel can be mounted in four different orientations (see page 49)
- Available in 4 and 6 circuit models
- Includes 4215 - 30 label set (see page 89)

Specifications

Panel Material	Reinforced Polycarbonate
Cover Material	Weather Resistant Thermoplastic
Maximum Voltage	12 Volts DC
Maximum Amperage Per Circuit	15 Amperes
Switch Type	OFF/ON Toggle with waterproof boot (see page 54)
Switch Rating	15 Amperes Maximum
Backlighting Voltage	12 Volts DC Nominal
Backlighting Amperage Draw	10mA/Illuminated Circuit
Circuit Breaker Type	Push Button Reset Only with waterproof boot (see page 40)
Circuit Breaker Rating	15 Amperes

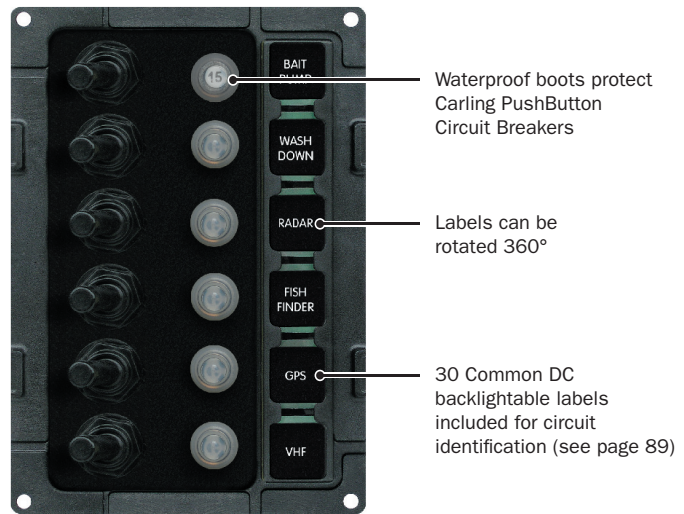
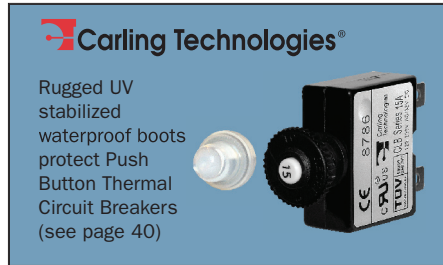
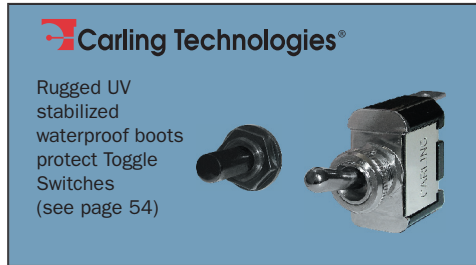
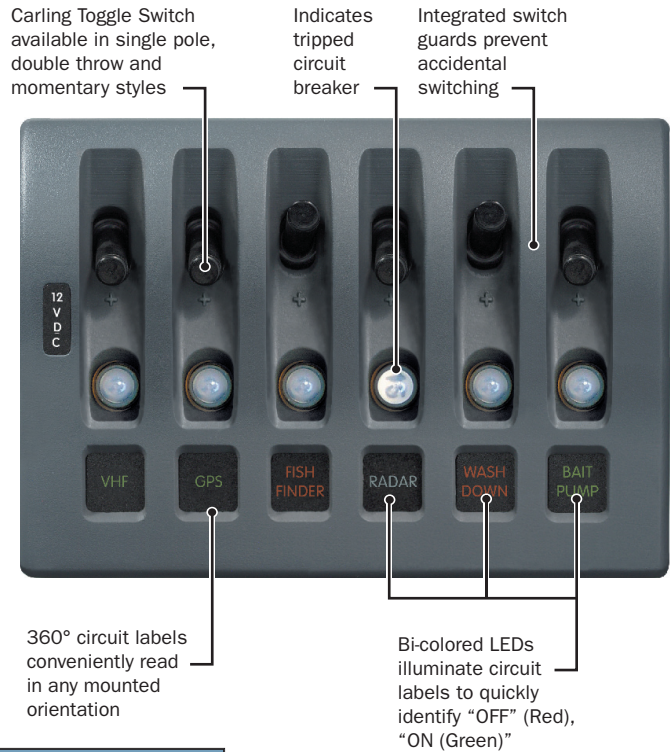

4 Position - Gray



4374

4 Position - White



4384

6 Position - Gray



4376

6 Position - White



4386

PN	Description	Weight Lb (Kg)
4374	4 Position - Gray	0.97 (0.44)
4376	6 Position - Gray	1.36 (0.62)
4384	4 Position - White	0.97 (0.44)
4386	6 Position - White	1.36 (0.62)

NEW PRODUCT

► For high volume applications contact Blue Sea Systems about custom configurations. Call 1-800-222-7617 for information.

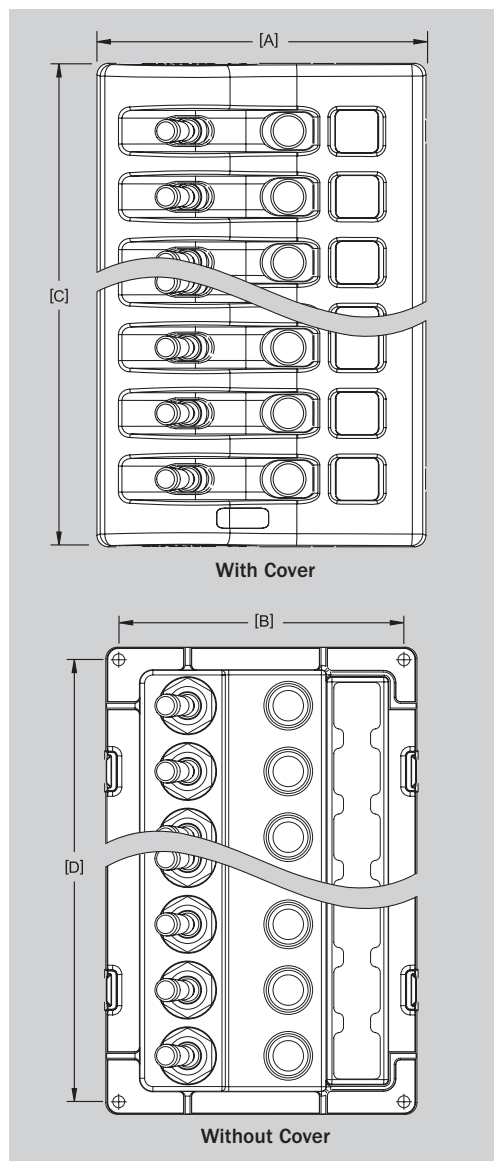

Description	[A] Width in" (mm)	[B] Mounting Centers in" (mm)	[C] Height in" (mm)	[D] Mounting Centers in" (mm)
4 Position	4.25 (107.95)	3.69 (93.73)	4.30 (109.22)	3.74 (95.00)
6 Position	4.25 (107.95)	3.69 (93.73)	6.00 (152.40)	5.44 (138.18)

Four Mounting Orientations



Each panel can be mounted in 4 orientations to expand location possibilities - Circuit labels can be rotated accordingly.

WeatherDeck™ Water Resistant Fuse Panels

Water resistant panel front withstands rain, sea spray, and hose spray washdown

- Designed for flybridge and open cockpit applications
- Constructed from corrosion resistant materials
- Independent label backlighting circuit for remote switching and dimming
- Compatible with all Blue Sea Systems Digital Dimmers (see page 104)
- UV stabilized and weather resistant faceplate
- Rated IP67 - "Temporary Immersion"
- Rugged UV stabilized waterproof boots
- Each panel can be mounted in four different orientations (see page 51)
- Available in 2, 4, 6, and 8 circuit models
- Includes 4215 - 30 label set (see page 89)
- Integrated ATO/ATC fuse based circuit protection

Specifications

Panel Material	Reinforced Polycarbonate
Cover Material	Weather Resistant Thermoplastic
Maximum Voltage	12 Volts DC
Maximum Amperage Per Circuit	15 Amperes
Switch Type	OFF/ON Toggle with waterproof boot (see page 54)
Switch Rating	15 Amperes maximum
Backlighting Voltage	12 Volts DC Nominal
Backlighting Amperage Draw	10mA/Illuminated Circuit
Fuse Type	ATO/ATC Automotive Blade-Type
Fuse Available	1-40 Amperes

Carling Toggle Switch available in single pole-double throw, double pole-double throw, and momentary styles

Integrated switch guards prevent accidental switching



360° circuit labels conveniently read in any mounted orientation

Bi-colored LEDs illuminate circuit labels to quickly identify "OFF" (Red), "ON" (Green), or "BLOWN" (No color) circuits



Rugged UV stabilized waterproof boots protect Carling Toggle Switches (see page 54)



ATO/ATC Blade Fuse on each circuit simplifies identification of Amperage (see page 59)

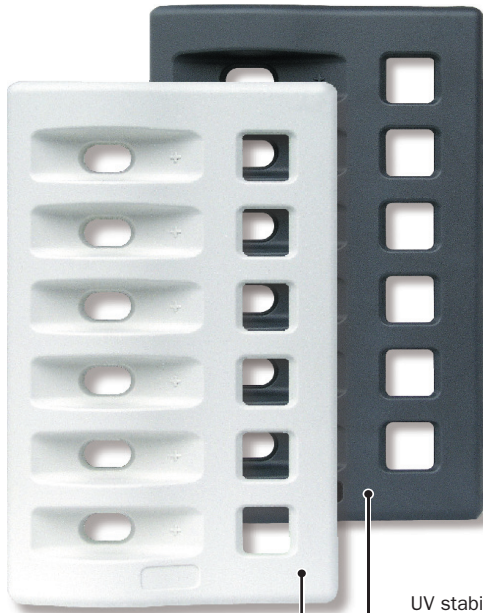

UV stabilized weather resistant faceplate snaps easily on and off, providing access to components, and concealing mounting screws

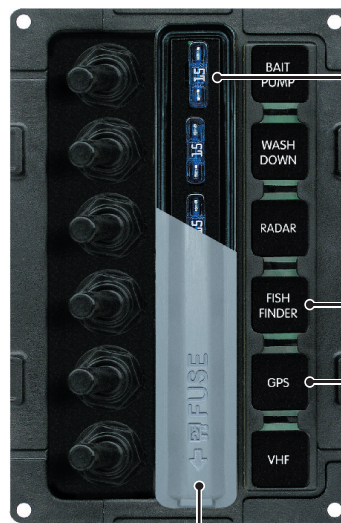

Fuses are easily accessed from the front of the panel

Labels can be rotated 360°

30 Common DC backlightable labels included for circuit identification (see page 89)

Fuses fully sealed with silicone rubber cover for water resistance

2 Position - Gray



4302

4 Position - Gray



4304

6 Position - Gray



4306

8 Position - Gray



4308

8 Position - White



4318

6 Position - White



4316

4 Position - White



4314

2 Position - White



4312

PN	Description	Weight Lb (Kg)
4302	2 Position - Gray	0.67 (0.30)
4304	4 Position - Gray	0.90 (0.41)
4306	6 Position - Gray	1.13 (0.51)
4308	8 Position - Gray	1.37 (0.62)
4312	2 Position - White	0.67 (0.30)
4314	4 Position - White	0.90 (0.41)
4316	6 Position - White	1.13 (0.51)
4318	8 Position - White	1.37 (0.62)

► For high volume applications Contact Blue Sea Systems about custom configurations. Call 1-800-222-7617 for information.

DC BRANCH POWER DISTRIBUTION AND CIRCUIT PROTECTION

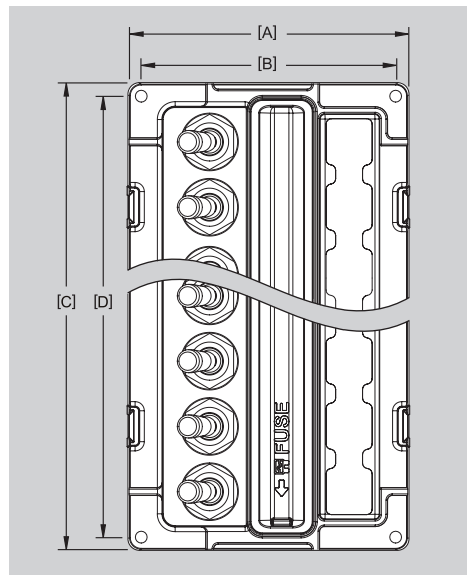

Description	[A] Width in" (mm)	[B] Mounting Centers in" (mm)	[C] Height in" (mm)	[D] Mounting Centers in" (mm)
2 Position	3.88 (98.40)	3.31 (84.14)	2.60 (66.00)	2.04 (51.75)
4 Position	3.88 (98.40)	3.31 (84.14)	4.30 (109.20)	3.74 (94.93)
6 Position	3.88 (98.40)	3.31 (84.14)	6.00 (152.40)	5.44 (138.11)
8 Position	3.88 (98.40)	3.31 (84.14)	7.70 (195.60)	7.14 (181.29)

Four Mounting Orientations

Each panel can be mounted in 4 orientations to expand location possibilities - Circuit labels can be rotated accordingly.

Water Resistant Circuit Breaker Panels

Common Features

- Designed for flybridge and open cockpit applications
- Water resistant ON-OFF Contura Switches
- Watertight mounting gasket
- Push Button Circuit Breaker with waterproof boot (see page 40)
- Rated IP66 - "Use on Shipdecks"
- Ignition protected - Safe for installation aboard gasoline powered boats
- Meets UL1500 and ISO 8846 ignition protection requirements
- Countersunk mounting holes throughout
- Heavy 1/8" aluminum material
- Two-part polyurethane white or black finish
- "ON" indicating LEDs embedded in switch
- MIL-C-5541C or equivalent immersion undercoating for lifetime corrosion resistance
- Completely wired and ready to install
- Includes set of 60 common DC labels (see page 90)

NOTE: Water resistant panel labels are not backlightable

Specifications

Voltage	12 or 24 Volts DC
Switch Rating	20 Amperes@12 Volts DC 15 Amperes@24 Volts DC
Switch LED Amperage Draw	18 Milliampères each
Circuit Breaker Rating	15 Amperes
Panel Cumulative Rating	45 Amperes
CE marked	

Water resistant panel front withstands rain, sea spray, and hose spray washdown

8 Position - Horizontal

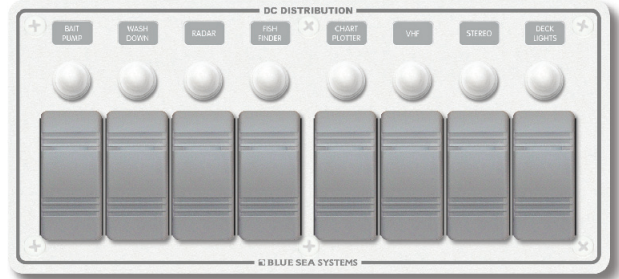

8271

8 Position - Horizontal



8371

6 Position - Vertical



8273

6 Position - Vertical



8373

3 Position - Vertical

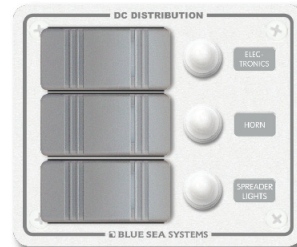

8274

4 Position - Horizontal

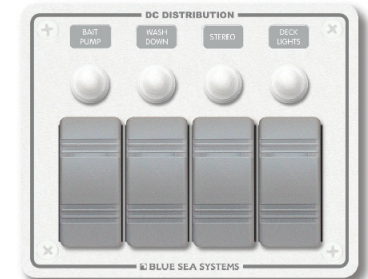

8272

3 Position - Vertical



8374

4 Position - Horizontal



8372

PN	Description	Color	Width in" (mm)	Height in" (mm)	Weight Lb (Kg)
8274	3 Position - Vertical	White	4.50 (114.30)	3.75 (95.25)	0.60 (0.27)
8272	4 Position - Horizontal	White	5.25 (133.35)	4.25 (107.95)	0.77 (0.35)
8273	6 Position - Vertical	White	4.50 (114.30)	7.50 (190.50)	0.90 (0.41)
8271	8 Position - Horizontal	White	9.37 (238.00)	4.25 (107.95)	1.34 (0.61)
8374	3 Position - Vertical	Black	4.50 (114.30)	3.75 (95.25)	0.60 (0.27)
8372	4 Position - Horizontal	Black	5.25 (133.35)	4.25 (107.95)	0.77 (0.35)
8373	6 Position - Vertical	Black	4.50 (114.30)	7.50 (190.50)	0.90 (0.41)
8371	8 Position - Horizontal	Black	9.37 (238.00)	4.25 (107.95)	1.34 (0.61)

Carling Technologies®

Rugged UV stabilized waterproof boots protect Push Button Thermal Circuit Breakers (see page 40)

DC BRANCH POWER DISTRIBUTION AND CIRCUIT PROTECTION

Water resistant panel front withstands rain, sea spray, and hose spray washdown

6 Position - Vertical

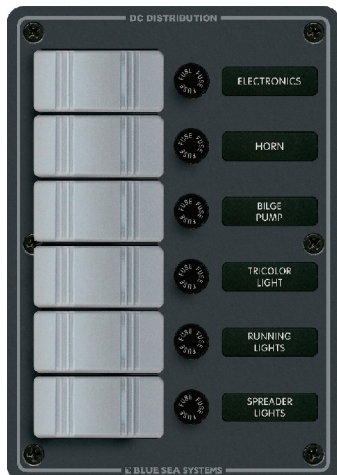

8053



3 Position - Vertical



8054

8 Position - Horizontal



8261

4 Position - Horizontal



8262

Water Resistant Fuse Panels

Common Features

- Designed for flybridge and open cockpit applications
- Water resistant ON-OFF Contura Switches
- Watertight mounting gasket included
- Water resistant fuse holders accept commonly available AGC (Fast Acting) and MDL (Slow Blow) glass fuses (see page 59)
- Countersunk mounting holes throughout
- Heavy 1/8" aluminum material
- Two-part polyurethane slate gray finish
- "ON" indicating LEDs embedded in switches
- Over 500 labels available (see pages 91-94)
- Industry standard height and width
- Mil-Spec chemical treatment via immersion to protect every surface detail from corrosion
- Completely wired and ready to install

NOTE: Water resistant panel labels are not backlightable

Vertical Fuse Panel Features

- Industry standard height and width
- Includes set of 30 standard format common DC labels*

Horizontal Fuse Panel Features

- Designed for height restricted installations
- Compact labels minimize panel space requirements
- Includes set of 60 small format common DC labels*

* See page 81

Specifications

Voltage	12 or 24 Volts DC
Switch Rating	20 Ampere@12 Volts DC 15 Ampere@24 Volts DC
Switch LED Amperage Draw	18 Milliampères each
Fuse Holder Rating	20 Amperes maximum
Panel Cumulative Rating	45 Amperes

PN	Description	Width in" (mm)	Height in" (mm)	Weight Lb (Kg)
8054	3 Position - Vertical	5.25 (133.35)	3.75 (95.25)	0.60 (0.27)
8053	6 Position - Vertical	5.25 (133.35)	7.50 (190.50)	0.90 (0.41)
8262	4 Position - Horizontal	5.25 (133.35)	3.75 (95.25)	0.77 (0.35)
8261	8 Position - Horizontal	9.37 (238.00)	3.75 (95.25)	1.34 (0.61)

Water resistant panel front withstands rain, sea spray, and hose spray washdown

Easy to open, water resistant fuse holder (see page 54)



8263

Water Resistant Bilge Pump Control Panel

- Designed for flybridge and open cockpit applications
- Water resistant (ON)-OFF-AUTO Contura Switch
- Watertight mounting gasket
- Water resistant fuse holders accept commonly available AGC (Fast Acting) and MDL (Slow Blow) glass fuses (see page 59)
- Countersunk mounting holes throughout
- Heavy 1/8" aluminum material
- Two-part polyurethane slate gray finish
- "ON" indicating LEDs embedded in switch
- Industry standard height and width
- Mil-Spec chemical treatment via immersion to protect every surface detail from corrosion
- Completely wired and ready to install

NOTE: Water resistant panel labels are not backlightable

Specifications

Specifications match Water Resistant Fuse Panels (See above)

PN	Width in" (mm)	Height in" (mm)	Weight Lb (Kg)
8263	2.25 (57.15)	3.75 (95.25)	0.43 (0.20)

WeatherDeck™ Single Pole Toggle Switches

- Specially manufactured by Carling Technologies® for use in Blue Sea Systems WeatherDeck™ Water Resistant Panels (see pages 48-51)
- Nickel-plated brass and phenolic non-corrosive construction

Specifications

Rating: 250 Volts AC	10 Amperes
Rating: 125 Volts AC	15 Amperes
Rating: 12 Volts DC	15 Amperes
Terminal Size	0.25" (6.35mm)
Terminal Type	Quick Connect Tab

PN	Pole/Throw	Action
4150	SPST	OFF - ON
4151	SPST	OFF - (ON)
4152	SPDT	ON - OFF - ON
4153	SPDT	(ON) - OFF - ON
4154	SPDT	(ON) - OFF - (ON)

() = Momentary

► See pages 48-51 for Blue Sea Systems DC Water Resistant WeatherDeck™ Panels.



4150

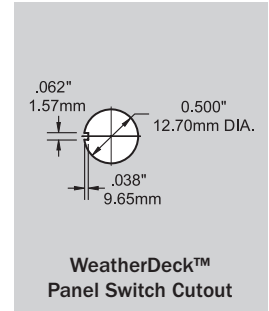
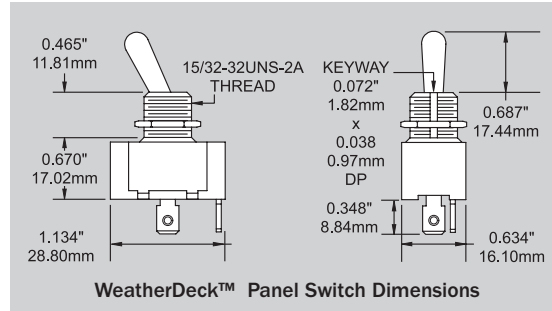

WeatherDeck™ Double Pole Toggle Switch NEW PRODUCT

- For use in Blue Sea Systems WeatherDeck™ Water Resistant Panels (see pages 48-51)
- Nickel-plated brass and phenolic non-corrosive construction

Specifications

Rating: 30 Volts DC	5 Amperes
Terminal Size	0.25" (6.35mm)
Terminal Type	Quick Connect Tab

PN	Pole/Throw	Action
4155	DPDT	ON-OFF-ON

NEW PRODUCT

► See pages 48-51 for Blue Sea Systems DC Water Resistant WeatherDeck™ Panels.



4155

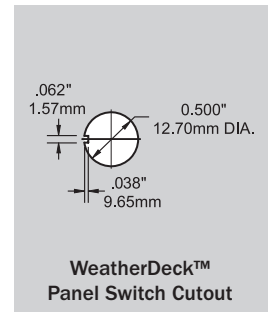
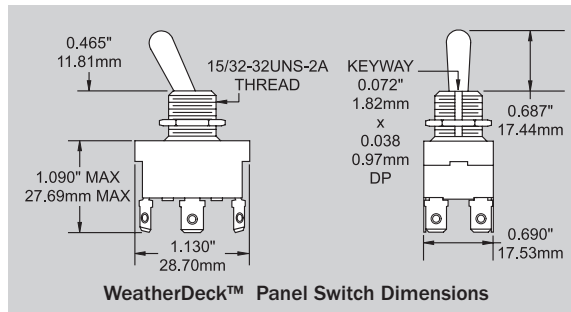

DC BRANCH POWER DISTRIBUTION AND CIRCUIT PROTECTION

WeatherDeck™ Toggle Switch Waterproof Boots

- Replaces dress nut for mounting on WeatherDeck™ Panel Switches
- UV resistant material resists discoloration and cracking

Specifications

Case Material	UV Resistant Silicone Rubber
Thread Material	Nickel Plated Brass
Thread	15/32"-32UNS-2A

PN	Description	Weight Lb (Kg)
4138	Black Toggle Switch waterproof boot	0.03 (0.01)

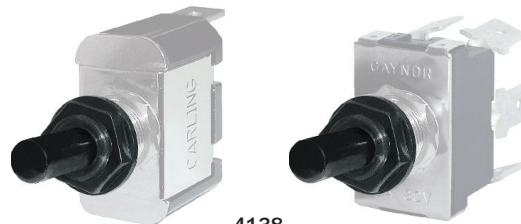

4138

Water Resistant Fuse Holder

- Improved, easy to open, water resistant fuse holder
- Withstands water exposure normally encountered in above deck applications: rain, sea spray or hose spray washdown

PN	Description	Weight Lb (Kg)
5021	Water Resistant Fuse Holder	0.02 (0.01)



5021



Water Resistant Contura Switches **IP**

- Vibration, shock, thermoshock, moisture and salt spray resistant
- Specially manufactured for use in Blue Sea Systems Water Resistant Panels
- Ignition Protected - Safe for installation aboard gasoline powered boats
- Meets UL 1500 and ISO 8846 ignition protection requirements

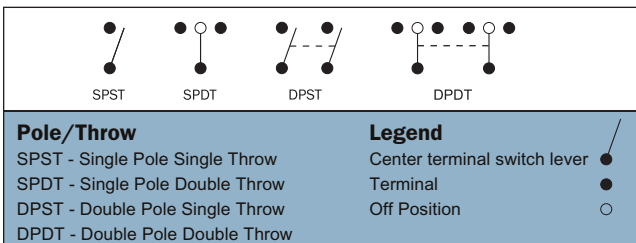

Specifications

Rating: 12 Volts DC	20 Amperes
Rating: 24 Volts DC	15 Amperes
Lighted	LED rated 100,000 hours 1/2 life
Seals	Internal and external gasket panel seal
Temperature Rating	-40°C to 85°C
Mounting Hole	1.45" x 0.83" (36.83mm x 21.08mm)
LED Amperage	18 Milliampere

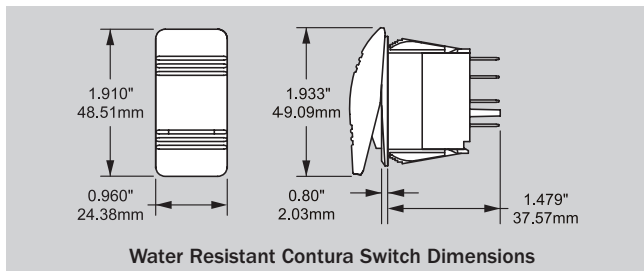

▶ See pages 52-53 for Blue Sea Systems DC Water Resistant Panels.

PN Gray	PN Black	Pole/Throw	Action	Embedded LEDs
8230	8282	SPST	OFF - ON	1
8231	8292	SPST	OFF - (ON)	0
8232	8283	SPDT	ON - OFF - ON	2
8233	8284	SPDT	(ON) - OFF - ON	1
8234	8285	SPDT	(ON) - OFF - (ON)	0
8218	8287	DPST	OFF - ON	1
8219	8288	DPST	OFF - (ON)	0
8220	8286	DPDT	ON - OFF - ON	2
8221	8289	DPDT	(ON) - OFF - ON	1
8222	8290	DPDT	(ON) - OFF - (ON)	0
8275	-	DPDT	ON - ON	2

() = Momentary

IP IGNITION PROTECTED

Contura Switch Mounting Panels

- Modular design permits easy assembly in groups of varying sizes
- Mounting panels available in 1, 3 and 6 fixed position models
- Designed for mounting in 6 different panel thicknesses (see below):
 0.06" (1.57mm) 0.09" (2.36mm) 0.13" (3.17mm)
 0.19" (4.75mm) 0.25" (6.35mm) 0.38" (9.52mm)

PN	Description	Width in" (mm)	Height in" (mm)
8267	End Mounting Panel	1.19 (30.14)	2.30 (58.42)
8266	Center Mounting Panel	1.03 (26.26)	2.30 (58.42)
8268	1 Position Mounting Panel	1.34 (34.03)	2.30 (58.42)
8259	3 Position Mounting Panel	3.40 (86.36)	2.30 (58.42)
8260	6 Position Mounting Panel	6.49 (164.85)	2.30 (58.42)

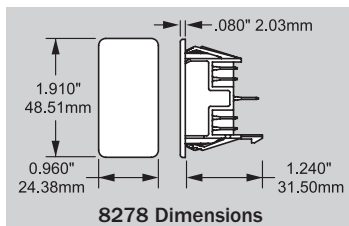
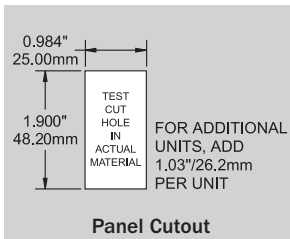
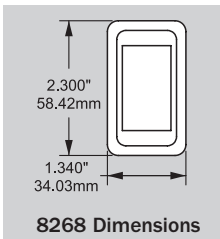
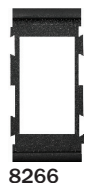
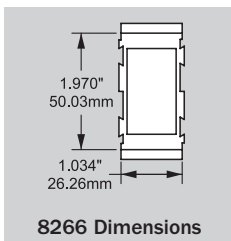
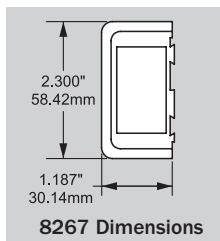
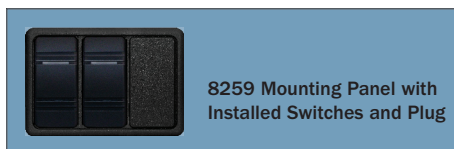

Contura Switch Mounting Panel Plug

- For use with Contura Switch Mounting Panels (see above)

PN	Description
8278	Mounting Panel Plug



PN Gray	PN Black	Number of Lenses
8299	8296	None
8297	8294	Single
8298	8295	Double
8293	Actuator Removal Tool	

Contura Switch Actuators

- Mounts on any Blue Sea Systems Contura switch
- Constructed of thermal plastic polycarbonate with a hard nylon - surface overlay
- For each embedded LED, there is a corresponding number of lenses

ST* Glass Fuse Blocks

***Screw Terminal**

- Clear insulating cover with label recesses accept large format Blue Sea Systems labels (see pages 90-94)
- Cover insulates all conductive parts, satisfying ABYC/USCG requirements and stores spare fuses
- Tin-plated copper buses and Phosphor Bronze fuse clips give 30 Amperes rating per circuit
- Accepts AGC (Fast Acting), MDL (Time-Delay) and all other 3AG Glass Fuses (see page 59)

Specifications

Base Material	Reinforced Polycarbonate
Cover Material	Polycarbonate
AGC/MDL Fuses available	1/8 to 30 Amperes
Screw Terminal	#8-32 with Captive Star Lockwasher
Maximum Amperage per circuit	30 Amperes
Maximum Amperage block	100 Amperes
Maximum Voltage	32 Volts DC

PN	Description	Weight Lb (Kg)
5015	6 circuit with negative bus	0.52 (0.24)
5018	6 circuit	0.42 (0.19)

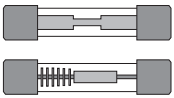

▶ See page 59 for AGC and MDL Fuses.

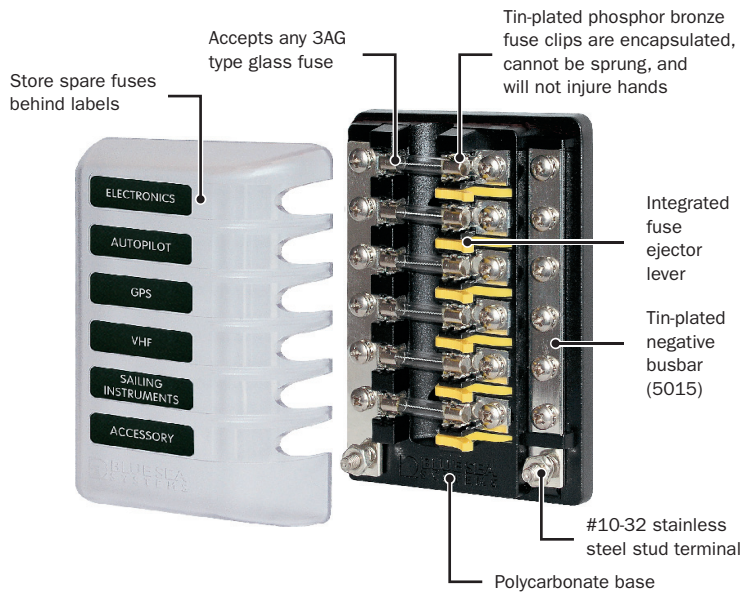

DC BRANCH POWER DISTRIBUTION AND CIRCUIT PROTECTION

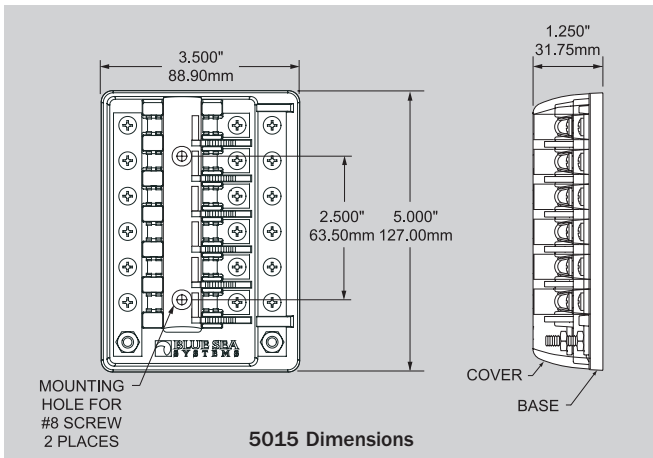

6 Circuit with Negative Bus



5015

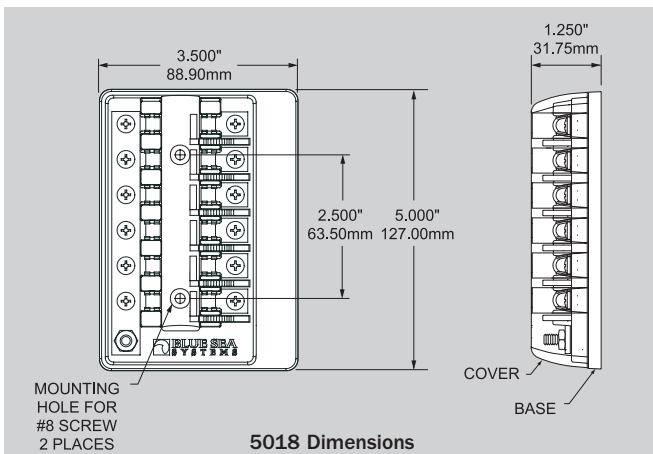

6 Circuit



5018

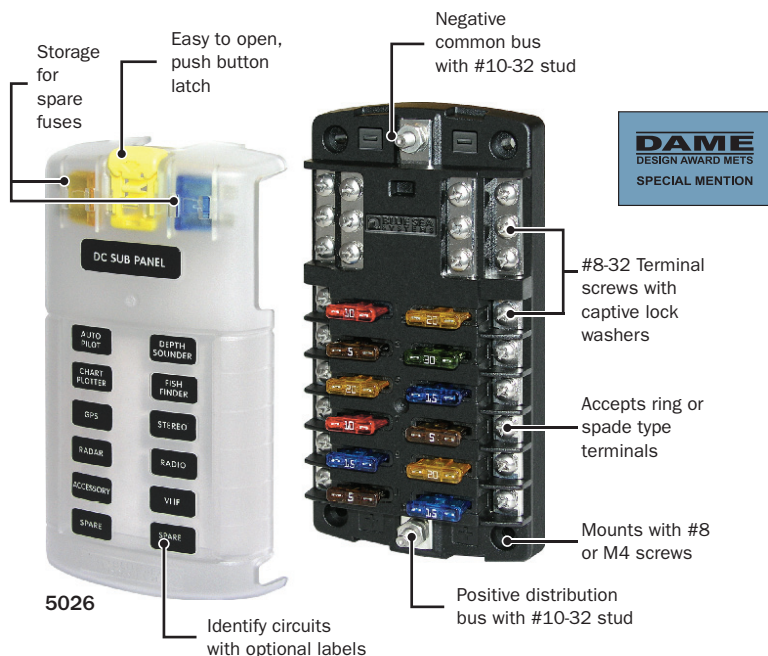

ST* Blade Fuse Blocks

***Screw Terminal**

- Clear insulating cover with label recess accept small format Blue Sea Systems labels (see pages 90-94)
- Cover satisfies all ABYC/USCG requirements
- Tin-plated copper buses and fuse clips give 30 Amperes rating per circuit
- Accepts ATO and ATC fast acting blade fuses (see page 59)
- A wide variety of circuit identification labels available (see pages 90)
- 20 write-on circuit labels included, excluding 5030, 5031, 5033, and 5034

Specifications

Base Material	Reinforced Polycarbonate
Cover Material	Polycarbonate
ATO/ATC Fuses available	1 to 40 Amperes
Maximum Amperage per circuit	30 Amperes
Maximum Amperage per block	100 Amperes
Maximum Voltage	32 Volts DC

ST Blade Fuse Block With Cover		
PN	Description	Weight Lb (Kg)
5025	6 circuit with negative bus	0.55 (0.25)
5026	12 circuit with negative bus	0.75 (0.34)
5028	6 circuit	0.50 (0.23)
5029	12 circuit	0.68 (0.31)

ST Blade Fuse Block Without Cover		
PN	Description	Weight Lb (Kg)
5030	6 circuit with negative bus	0.47 (0.21)
5031	12 circuit with negative bus	0.65 (0.29)
5033	6 circuit	0.42 (0.19)
5034	12 circuit	0.59 (0.27)

Now accepts all European Blade Type fuses



▶ See page 59 for ATO/ATC Fuses.

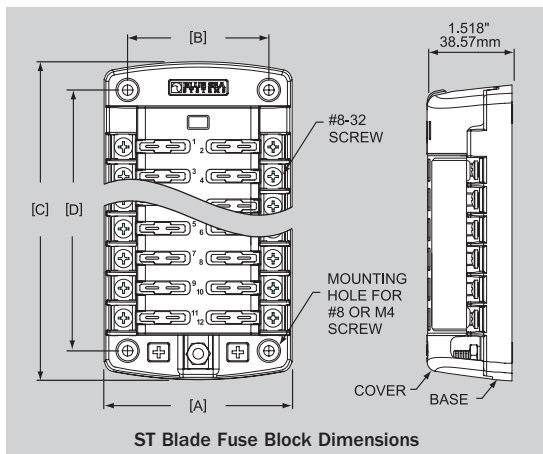

PN	[A] Width in" (mm)	[B] Mounting Centers in" (mm)	[C] Height in" (mm)	[D] Mounting Centers in" (mm)
5028/5033	3.315 (84.20)	2.500 (63.50)	3.652 (92.76)	2.639 (67.03)
5025/5030	3.315 (84.20)	2.500 (63.50)	4.894 (124.31)	3.881 (95.58)
5029/5034	3.315 (84.20)	2.500 (63.50)	5.230 (132.84)	4.217 (107.11)
5026/5031	3.315 (84.20)	2.500 (63.50)	6.472 (164.39)	5.459 (138.66)

MAXI™ Fuse Block

- The most economical fuse block for 30-80 Ampere fusing
- Snap-on terminal cover insulates all conductive parts, satisfying ABYC/USCG requirements
- Accepts wire sizes 18-4 AWG from sides or bottom
- For use on systems up to 32 Volts DC
- Ring terminal screws compress fuse blades within blocks for low resistance connections
- Accepts Maxi™ Fuses (see below)

Specifications

Base Material	Red Reinforced Polycarbonate
MAXI™ Fuses Available	30-80 Amperes
Maximum Amperage	80 Amperes
Maximum Voltage	32 Volts DC
Fuse Mounting Blocks	Tin-plated Brass



5006

► See below for MAXI™ Fuses.

PN	Description	Weight Lb (Kg)
5006	30-80A	0.26 (0.12)

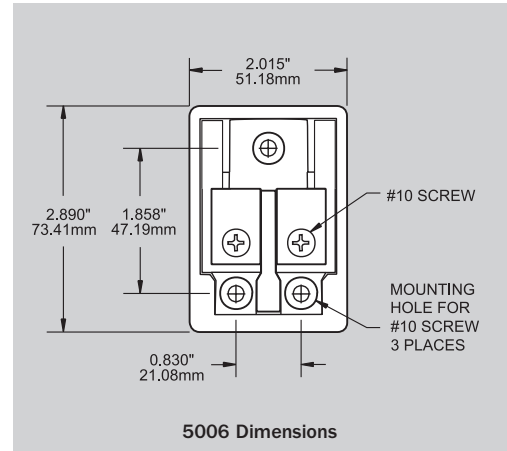
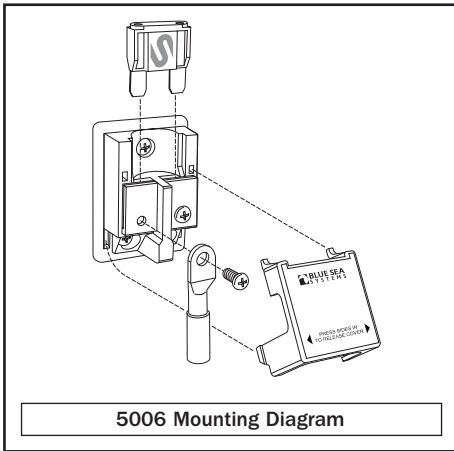

MAXI™ Fuses

- Economical
- Tin-plated connector blades for corrosion resistance
- Visible indication of blown condition

Specifications

Maximum Voltage	32 Volts DC
Interrupt Capacity	1,000 Amperes DC
Delay	See www.bluesea.com

PN	Amperage	Weight Lb (Kg)
5138	30A	0.04 (0.02)
5139	40A	0.04 (0.02)
5140	50A	0.04 (0.02)
5141	60A	0.04 (0.02)
5142	70A	0.04 (0.02)
5143	80A	0.04 (0.02)

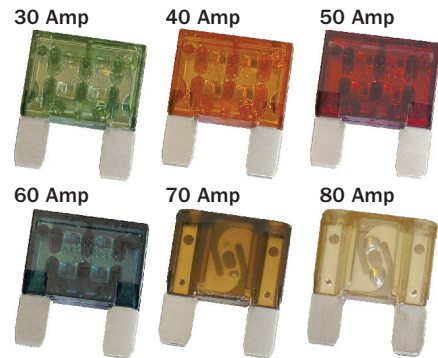

► See above for Blue Sea Systems' MAXI™ Fuse Block.

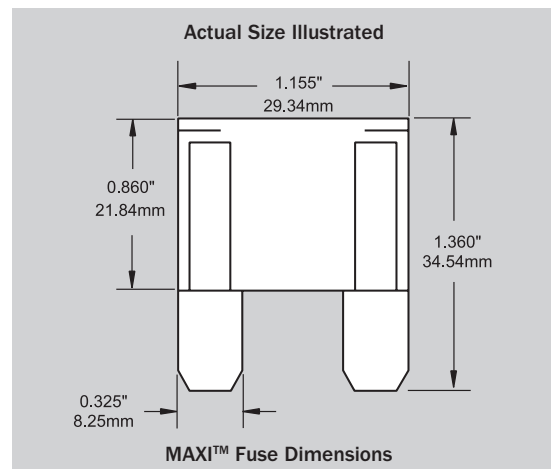

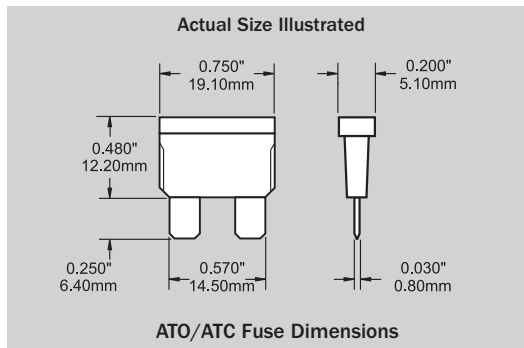
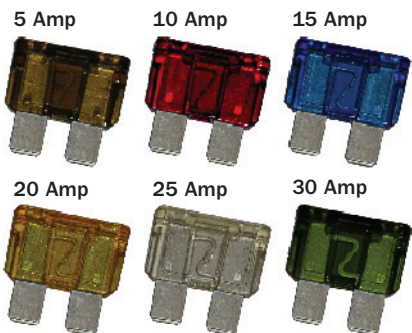

ATO/ATC Fuses

- Fast-acting type fuses ideal for electronic devices
- Standard circuit protection device for automobiles and trucks
- Tin-plated connector blades for corrosion resistance
- Visible indication of blown condition
- Sold in packages of 2

Specifications

Maximum Voltage	32 Volts DC
Interrupt Capacity	1,000 Amperes DC
Delay	See www.blueseas.com
Weight per package	0.03Lb (0.01Kg)

PN	Amperage
5235	1A
5236	2A
5237	3A
5238	4A
5239	5A
5240	7.5A
5241	10A
5242	15A
5243	20A
5244	25A
5245	30A
5246	40A

- ▶ See page 57 for Blue Sea Systems ST* Blade Fuse Blocks.
* Screw Terminal
- ▶ See pages 50-51 for Blue Sea Systems WeatherDeck™ Water Resistant Fuse Panel



AGC



MDL

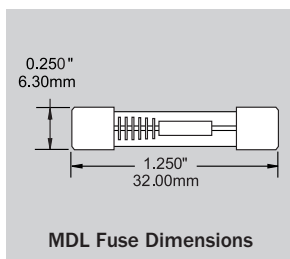
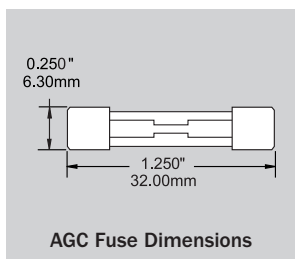

AGC/MDL 3AG Fuses

AGC

- UL listed 248-14/CSA certified
- Fast-acting glass fuses
- Sold in packages of 5

MDL

- UL listed 248-14/CSA certified
- Time-delay glass fuses for high inrush motor type loads
- Sold in packages of 2

Specifications

Maximum Voltage	32 Volts DC
Interrupt Capacity	1,000 Amperes DC
Delay	See www.blueseas.com
AGC - Weight per package	0.04Lb (0.02Kg)
MDL - Weight per package	0.03Lb (0.01Kg)

Automotive Blade Fuses (ATO/ATC) vs. Glass Fuses (AGC/MDL)

ATO/ATC Fuse Advantages:



- Color-coding makes determining amperage quick and easy.
- Body size and configuration makes inserting and extracting easier.
- Visibility of the fuse element makes identifying blown fuses easier.

AGC/MDL Fuse Advantages:



- Available in "fractional" sizes to protect delicate electronic circuits.
- Suitable for applications where both electronic and motor loads are being protected in the same fuse block.
- Less expensive and more widely available throughout the world.

PN AGC	PN MDL	Amperage
5200	-	1/8A
5201	-	1/4A
5202	5221	1/2A
5203	-	3/4A
5204	5222	1A
5205	5223	1.5A
5206	5224	2A
5207	5225	2.5A
5208	5226	3A
5209	-	4A
5210	5227	5A

PN AGC	PN MDL	Amperage
5211	-	6A
-	5228	6.25A
5212	-	7A
5213	5229	7.5A
5214	-	8A
5215	5230	10A
5216	-	12A
5217	5231	15A
5218	5232	20A
5219	5233	25A
5220	5234	30A

- ▶ See page 53 for Blue Sea Systems DC Water Resistant Fuse Panels.
- ▶ See page 56 for Blue Sea Systems ST* Glass Fuse Blocks.
* Screw Terminal

The AC Main Power System begins at the sources of AC power (Shore Power, Generator or Inverter). It ends at the Line terminal connection of the AC branch circuit breaker for the Hot wire and at the branch circuit connection block for the Neutral and Safety ground wires.

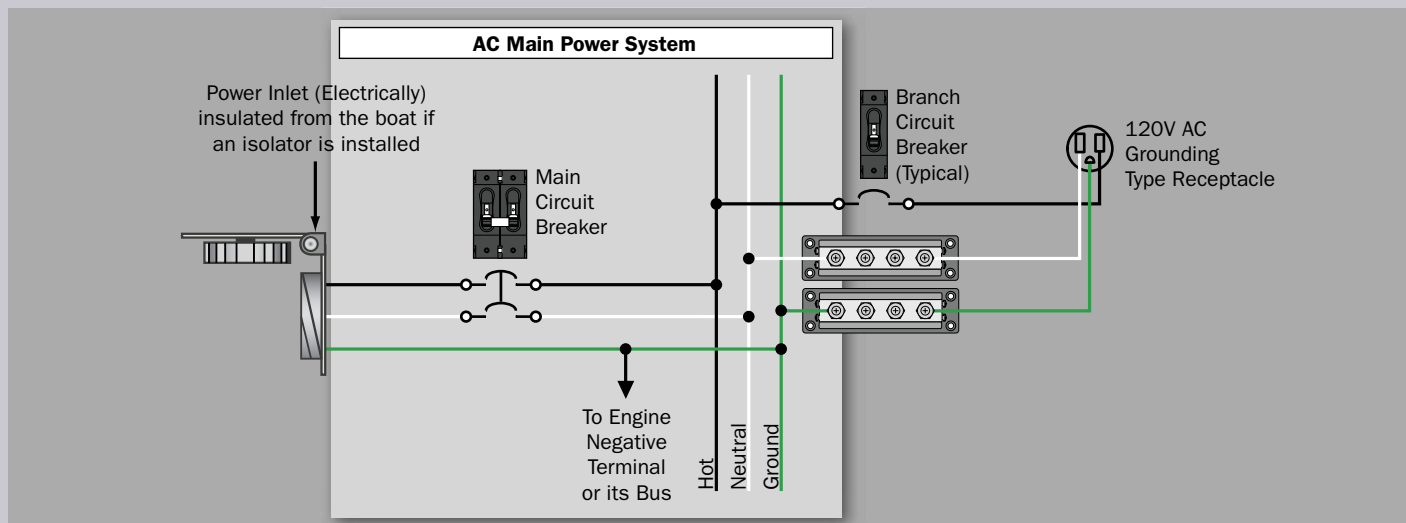

Purpose

- Provide a path for delivering power from the ship's sources of AC power to the AC branch distribution system
- Provide a path for returning fault currents to ground via the green safety ground wire
- Provide galvanic Isolation in the green safety ground wire
- Provide a means for disconnecting AC power when the boat is not in use or in emergencies
- Provide electrical separation to insure that two sources of AC power are never connected
- Provide circuit protection for neutral and line wires in the AC main system
- Provide ground fault protection (See RCD in Glossary page 124) in European Systems

System Configurations

Due to the nature of alternating current, the devices used to distribute AC power are frequently the same as the devices that perform AC circuit protection. Therefore, this section of the catalog contains both AC main distribution systems and AC main circuit protection, referred to collectively as AC main power systems. Before selecting components for an AC system, several important distinctions about AC power must be considered.

Direct Current (DC) vs. Alternating Current (AC)

In DC systems current flow is in one direction - from the point of higher voltage (electrical pressure) to lower voltage. In AC systems the voltage reverses 60 times each second (50 times each second in Europe and other parts of the world), called "cycles" or "Hertz" (Hz). This voltage reversal also reverses the current flow and gives this type of power its name - Alternating Current (AC). Because of this alternating current and the higher voltages it uses, (120 and 240 Volts AC vs. 12 or 24 Volts DC) the wiring configurations and components for AC current are different than DC.

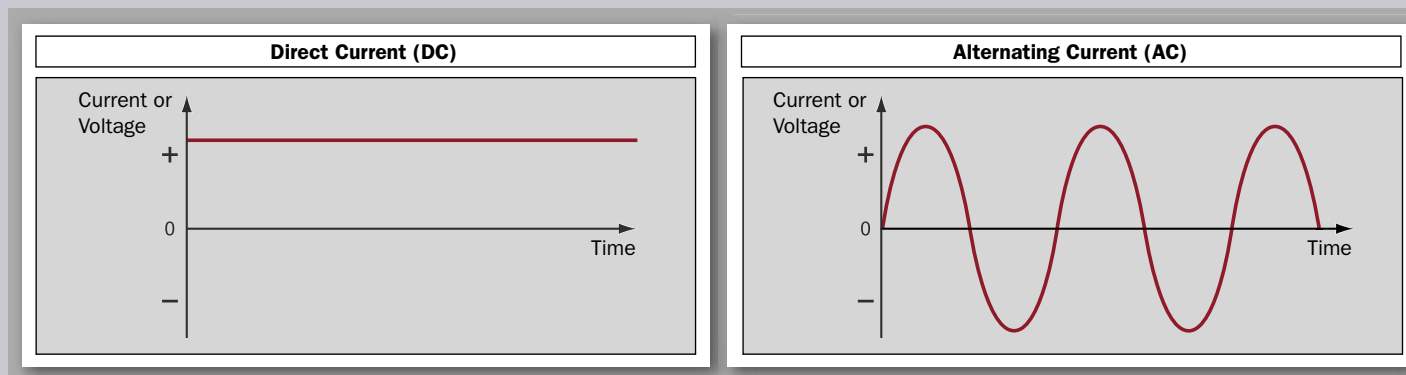

AC Wire Systems

The three most common AC systems used on boats are shown below. In all cases the ground, sometimes called safety ground to clarify its purpose and differentiate it from the DC ground or negative, is said to be a “normally non-current carrying wire”. Its purpose is to provide the lowest resistance path for AC currents that have strayed from their proper containment in the normally current carrying hot and neutral wires. The ground wire is connected to the exterior conductive parts of AC devices that could be touched by a person during normal operation and conducts errant AC currents safely to ground rather than passing them through a human body. The ground wire is never passed through a switch or circuit breaker.

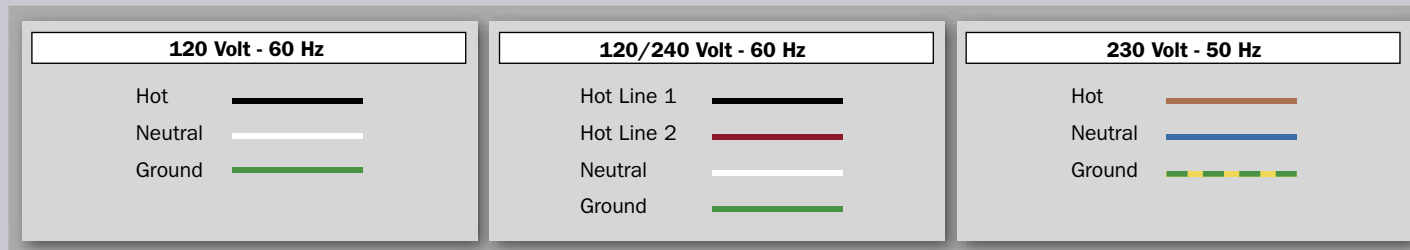

Physical configuration of AC Main circuit breakers

Sources of AC power, whether shore power or on board generators and inverters, always have a circuit breaker near the power source. This circuit breaker is designated the AC main circuit breaker. The AC main circuit breaker always has a pole for each of the hot and neutral wires in the circuit assuring that circuit protection functions are not compromised in reverse polarity (see page 124) situations. The requirement stipulates that 120 Volt systems use a double pole main circuit breaker. Although not required by the ABYC Standards, three pole circuit breakers with the Neutral connected through the third pole are sometimes used on 120/240 Volt systems. In cases where the main circuit breaker is also used for source selection the Neutral must be switched to maintain the correct Neutral connection.

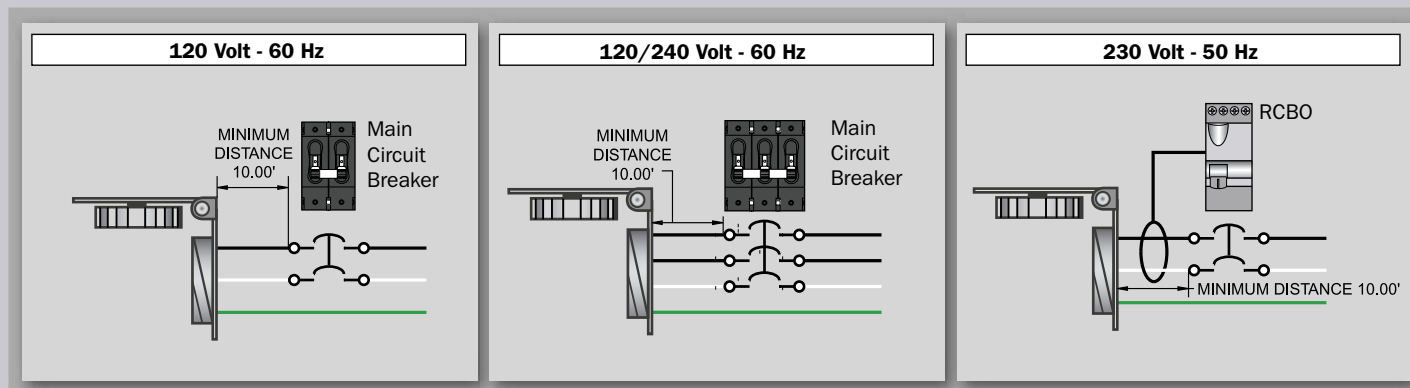

Devices Qualifying as AC Main Circuit Breakers

In order to qualify as an AC main circuit breaker four primary characteristics must be present:

1. The circuit breaker must have an Ampere Interrupt Rating (AIC) meeting those requirements of the table below:

Ampere Interrupt Rating - ABYC Table

AC Shore Power Source	Main Circuit Breaker	Branch Circuit Breaker
120V - 30A	3,000	3,000
120V - 50A	3,000	3,000
120/240V - 50A	5,000	3,000
240V - 50A	5,000	3,000

2. The circuit breaker must be multiple pole, usually 2 or 3 (see “AC Wire Systems” above).
3. The circuit breaker must be rated for the appropriate AC system voltage in which it will be used.
4. The circuit breaker must be available in amperages appropriate to the design amperage of the system.

In the USA, this is generally 30 and 50 Amperes, while European systems are generally 16 and 32 Amperes.

European systems also require that a Residual Current Device (RCD) (see page 124) be installed on the entire AC system and this is generally implemented as Residual Current Breaker Overload (RCBO) (see page 124) device which incorporates a double pole circuit breaker and an RCD into a single device.

AC Source Selectors

AC sources from shore power, generator sets, inverters, and isolation transformers must be switched in such a way that ensures only one AC source is connected and all other AC sources are completely disconnected. Hazards to personnel and damage to equipment can occur if sources are improperly connected to each other. A properly designed selector system will allow only the appropriate neutral and hot source conductors to connect to the load without allowing the system to supply power backwards to unused connections or sources. Neutrals and grounds are treated differently with on board sources than with shore power and the system must handle each accordingly.

In marine AC systems there are two common methods used to assure that two different AC sources are never connected to each other. AC Lockout Slides are devices that slide between circuit breaker handles and allow only 1 handle to be in the "ON" position at a time. Circuit breakers with properly configured slides can have different numbers of poles and different current ratings for each breaker. AC Rotary Switches use a switching mechanism to prevent connection of different AC sources. Each system has its advantages and disadvantages as shown below:

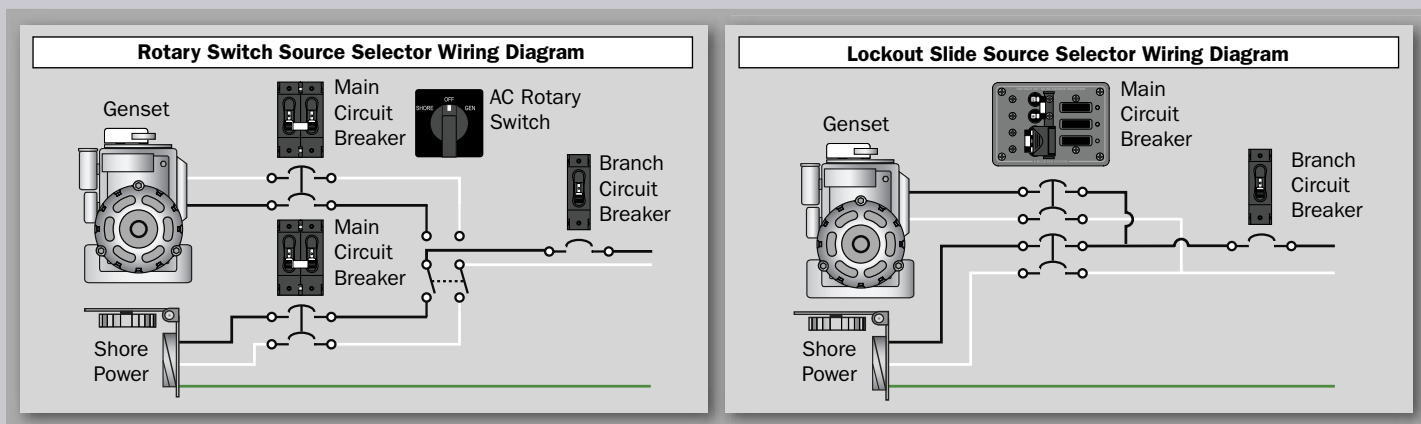

Advantages

- Compact
- Can handle up to 4 sources
- More intuitive operation

Disadvantage

- Expensive relative to lockout slides
- Requires additional circuit protection

Advantages

- Integrates circuit protection and source selection into 1 unit
- Lower cost for both circuit protection and source selection
- Flexible configurations for dual shore cords

Disadvantages

- Require more space
- Impractical for more than 3 sources

Selecting AC Circuit Protection

1) Determine these two numbers:

- The amperage capacity of the smallest wire in the circuit to be protected. See the ABYC Ampacity Rating Table on page 28.
- The maximum continuous current that will flow in the circuit.

2) Consult the ABYC Interrupt Rating table on page 61 for the minimum Interrupt rating required for the application.

Limit the selection to a circuit breaker type that meets the interrupt capacity requirement.

3) Select a circuit breaker amperage rating that is:

- Smaller than the amperage capacity of the smallest wire (from step 1a)
- Larger than the maximum continuous current that will flow in the circuit (from step 1b) It is recommended that the amperage rating be at the upper end of this range to allow for surge currents and increase in the number of devices on the circuit.

4) Verify that the voltage rating of the selected circuit breaker meets or exceeds the circuit voltage.

5) There are other issues that may be considered by reading ABYC E-11.12 Circuit Protection.

See www.blueseas.com for ABYC Standards.

Circuit Protection Device Comparison Table

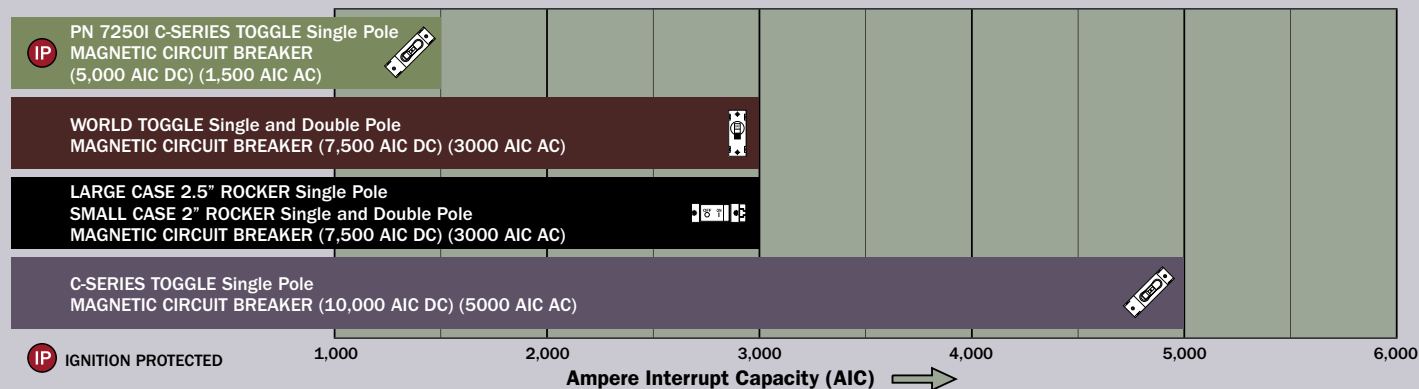

Single and Double Pole Toggle World Circuit Breakers

The World Circuit Breaker meets all American Boat and Yacht Council (ABYC) standards, is UL 1077 recognized, TUV certified, CE marked for Europe, and CSA certified for Canada.

- The industry standard circuit breaker for Blue Sea Systems electrical panels
- Combines switching and circuit protection into a single device
- Double pole used as 120/240 Volt AC branch circuit breakers to switch line 1 and line 2
- “Trip Free” design cannot be held “ON” during fault current condition
- For circuit breaker mounting panels (see page 87)

Specifications

Circuit Breaker Type	Magnetic Hydraulic - Trip free
Maximum Amperage	50 Amperes AC/DC
Maximum Voltage	277 Volts AC/65 Volts DC
Rated Switch Cycles	10,000 @ rated amperage and voltage
Delay	See www.blueseasea.com
Weight	Single Pole 0.17Lb (0.08Kg) Double Pole 0.34Lb (0.15Kg)
Mounting screw	#6-32
Terminal screw	#10-32 SS with external tooth lockwasher

CE marked

7200



7233



Interrupt Ratings (see ABYC Interrupt rating Requirements page 62)

World Circuit Breakers - Single and Double Pole			
		UL 1077 - UL/CSA (US/Canada) ¹	EN60934 - TUV (Europe)
Voltage	Current	Interrupt Ratings	Interrupt Ratings
65V DC	5-50A	7,500A	1,500A
120V AC	5-50A	3,000A	1,500A
120/240V AC	10-50A	3,000A	1,500A
250V AC	10-50A	3,000A	1,500A

¹ UL Recognized

Single Pole		
PN	Color	Amperage
7200	Black	5A
7201	Red	5A
7202	White	5A
7347	Black	8A
7299	White	8A
7204	Black	10A
7205	Red	10A
7206	White	10A
7208	Black	15A
7209	Red	15A
7210	White	15A
7212	Black	20A
7213	Red	20A
7214	White	20A
7216	Black	25A
7217	Red	25A

Single Pole		
PN	Color	Amperage
7218	White	25A
7220	Black	30A
7221	Red	30A
7222	White	30A
7224	Black	40A
7225	Red	40A
7226	White	40A
7228	Black	50A
7229	Red	50A
7230	White	50A

Double Pole		
PN	Color	Amperage
7232	Black	10A
7233	White	10A
7234	Black	15A
7235	White	15A
7348	Black	16A
7294	White	16A
7236	Black	20A
7260	White	20A
7237	Black	30A
7238	White	30A
7349	Black	32A
7295	White	32A
7239	Black	40A
7240	White	40A
7241	Black	50A
7242	White	50A

NEW PRODUCT

AC MAIN POWER DISTRIBUTION AND CIRCUIT PROTECTION

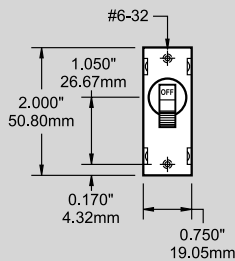

Single Pole Toggle Circuit Breaker Dimensions

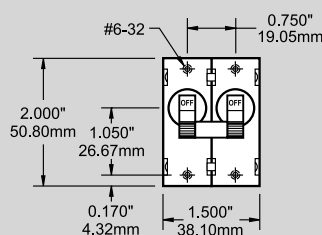

Double Pole Toggle Circuit Breaker Dimensions

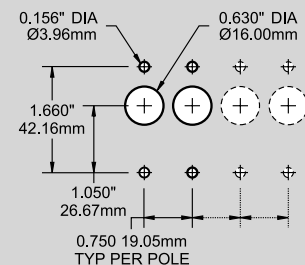

Toggle Panel Cutout Detail

Single and Double Pole Small Case 2" Rocker Circuit Breakers

- Rocker actuator gives modern appearance to electrical distribution panels
- Dual color rocker gives clear visual indication of handle position
- Double pole used as 120/240 Volt AC branch circuit breakers to switch line 1 and line 2
- "Trip Free" design cannot be held "ON" during fault current condition

Specifications

Circuit Breaker Type	Magnetic Hydraulic - Trip free
Maximum Amperage	See table below
Maximum Voltage	See table below
Rated Switch Cycles	10,000@rated amperage and voltage
Delay	See www.blueseas.com
Mounting screw	#6-32
Terminal screw	#10-32 SS with external tooth lockwasher
CE marked	



7300



7320

AIRPAX

Interrupt Ratings (see ABYC Interrupt rating Requirements page 62)

Small Case Rocker Circuit Breakers - Single and Double Pole			
		UL 1077 - UL/CSA (US/Canada) ¹	EN60934 - VDE (Europe)
Voltage	Current	Interrupt Ratings	Interrupt Ratings
65V DC	5-50A	-	2,000A
80V DC	5-30A	-	4,000A
80V DC	5-50A	7,500A	-
125V AC	5-50A	3,000A	-
240V AC	5-50A	2,000A	-
250V AC	5-30A	2,000A	2,000A
250V AC	5-50A	-	2,000A

¹ UL Recognized

PN	Poles	Amperage	Weight Lb (Kg)	PN	Poles	Amperage	Weight Lb (Kg)
7300	1	5A	0.19 (0.09)	7320	2	10A	0.36 (0.16)
7301	1	8A	0.19 (0.09)	7321	2	15A	0.36 (0.16)
7302	1	10A	0.19 (0.09)	7322	2	16A	0.36 (0.16)
7303	1	15A	0.19 (0.09)	7323	2	20A	0.36 (0.16)
7304	1	20A	0.19 (0.09)	7324	2	30A	0.36 (0.16)
7305	1	25A	0.19 (0.09)	7325	2	32A	0.36 (0.16)
7306	1	30A	0.19 (0.09)	7326	2	40A	0.36 (0.16)
7307	1	40A	0.19 (0.09)	7327	2	50A	0.36 (0.16)
7308	1	50A	0.19 (0.09)	4110	-	Panel Plug Kit	-

AC MAIN POWER DISTRIBUTION AND CIRCUIT PROTECTION

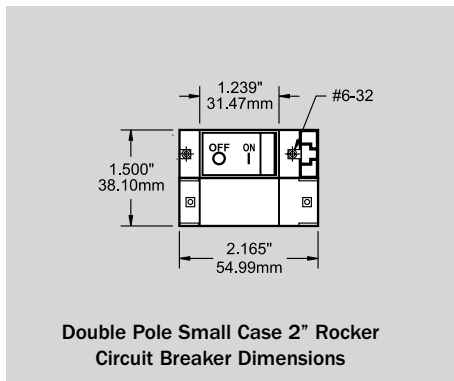
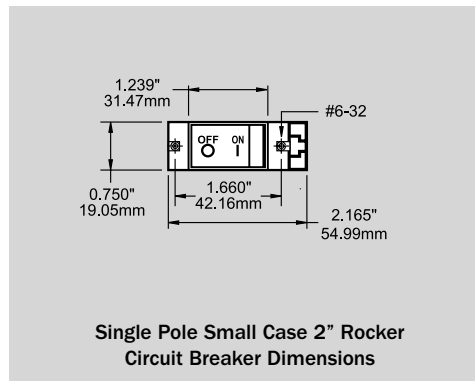
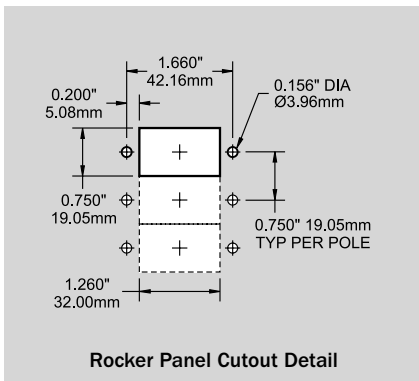



7251



7287

C-Series Double and Triple Pole Circuit Breakers

- 5,000 Ampere interrupt capacity to meet ABYC requirements for 120/240 Volt 50 Ampere main protection
- Double pole can be used as 120 Volt AC main circuit breaker to switch line 1 and line 2
- Triple pole can be used as 240 Volt AC main circuit breaker to switch line 1 and line 2
- Double and triple pole circuit breakers will trip all poles if any one pole trips
- "Trip Free" design cannot be held "ON" during fault current condition

Specifications

Circuit Breaker Type	Magnetic
Maximum Amperage	100 Amperes AC
Maximum Voltage	250 Volts AC
Delay	See www.blueseas.com

Interrupt Ratings (see ABYC Interrupt rating Requirements page 62)

C-Series Circuit Breakers - Double and Triple Pole			
		UL 1077 - UL/CSA (US/Canada) ¹	EN60934 - TUV (Europe)
Voltage	Current	Interrupt Ratings	Interrupt Ratings
125/250V AC	30-100A	5,000A	5,000A
250V AC	30-100A	5,000A	5,000A

¹ UL Recognized

► See page 74 for single pole C-Series Magnetic Circuit Breakers.

PN	Color	Poles	Amperage	Weight Lb (Kg)
7365	White	2	30A	0.56 (0.26)
7251	White	2	50A	0.56 (0.26)
7254	White	2	60A	0.56 (0.26)
7256	White	2	80A	0.56 (0.26)
7258	White	2	100A	0.56 (0.26)
7287	White	3	50A	0.93 (0.46)
7288	White	3	60A	0.93 (0.46)
7289	White	3	80A	0.93 (0.46)
7290	White	3	100A	0.93 (0.46)

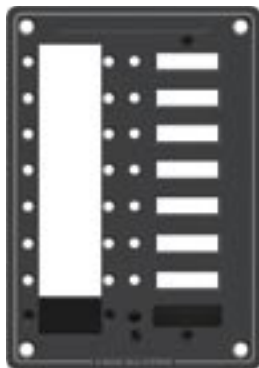
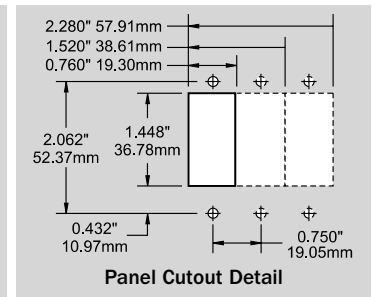
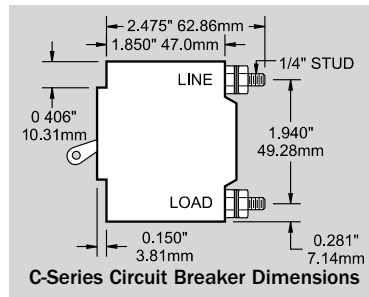
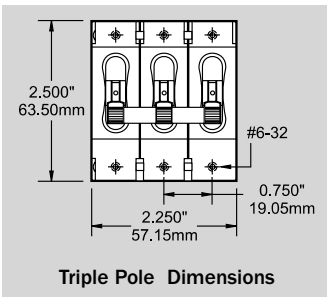
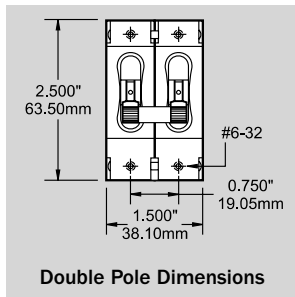

8087



8088

Magnetic Circuit Breaker Mounting Panels

- Designed for C-Series Magnetic Circuit Breakers (see above and page 32 and 74)
- Panel plugs can be inserted to fill blank positions
- Heavy 1/8" aluminum 5052 alloy
- Two-part polyurethane slate gray finish
- Accepts standard Blue Sea Systems backlightable labels (see pages 90-94)
- Accepts standard Blue Sea Systems "ON" indicating LEDs (see page 87)
- Industry standard height and width
- Optional Panel Plug Kit 8089 includes Circuit Breaker Mounting Screws, panel plug, LED plug, and blank label

PN	Description	Width in" (mm)	Height in"	Weight Lb (Kg)
8087	8 Position	5.25 (133.35)	7.50 (190.50)	0.40 (0.18)
8088	3 Position	5.25 (133.35)	3.75 (95.25)	0.28 (0.13)
8089	Panel Plug Kit	-	-	0.10 (0.04)

AC Main Only Toggle Circuit Breaker Panels

- Red reverse polarity indicating LED
- Safety ground screw on panel back
- Combines switching and circuit protection into a single device
- "Trip Free" design cannot be held "ON" during fault current condition

Specifications

Circuit Breaker Type: Magnetic Hydraulic - Trip free
 Panel Material: Heavy 1/8" aluminum 5052 alloy
 Primary Finish: Mil-C-5541C or equivalent immersion undercoating for lifetime corrosion resistance
 Final Panel Finish: 2-part polyurethane slate gray finish
 Circuit Breakers: Double Pole AC/DC Magnetic Toggle Circuit Breaker (see pages 63 and 72)
 Ratings: 65 Volts DC
 277 Volts AC Maximum
 Delay: See www.blueseas.com
 CE marked

▶ Available with a choice of white or black circuit breakers installed.

Main Only



8077/8079/8177*/8179*
 3077/3079/3177*/3179*

* 230 Volt (typical for European applications)

120 VOLT		AC Main Only Toggle Circuit Breaker Panels							
PN	PN	Description	Width in" (mm)	Height in" (mm)	Weight Lb (Kg)	Installed Double Pole Circuit Breakers			
						16A	30A	32A	50A
8077	3077	Main Only	2.63 (66.68)	3.75 (95.25)	0.51 (0.23)	-	1	-	-
8079	3079	Main Only	2.63 (66.68)	3.75 (95.25)	0.51 (0.23)	-	-	-	1

230 VOLT		AC Main Only Toggle Circuit Breaker Panels (Typical of Europe)							
PN	PN	Description	Width in" (mm)	Height in" (mm)	Weight Lb (Kg)	Installed Double Pole Circuit Breakers			
						16A	30A	32A	50A
8177	3177	Main Only	2.63 (66.68)	3.75 (95.25)	0.51 (0.23)	1	-	-	-
8179	3179	Main Only	2.63 (66.68)	3.75 (95.25)	0.51 (0.23)	-	-	1	-

▶ See page 76-83 For full selection of AC Circuit Breaker Panels.

AC Main Only Rocker Circuit Breaker Panels

- Red reverse polarity indicating LED
- Safety ground screw on panel back
- Rocker actuator gives modern appearance to electrical distribution panels
- Dual color rocker gives clear visual indication of handle position
- "Trip Free" design cannot be held "ON" during fault current condition

Specifications

Circuit Breaker Type: Magnetic Hydraulic - Trip free
 Panel Material: Heavy 1/8" aluminum 5052 alloy
 Primary Finish: Mil-C-5541C or equivalent immersion undercoating for lifetime corrosion resistance
 Final Panel Finish: 2-part polyurethane slate gray finish
 Circuit Breakers: Double Pole AC/DC Magnetic Rocker Circuit Breaker (See pages 64 and 73)
 Ratings: 65 Volts DC
 277 Volts AC Maximum
 Delay: See www.blueseas.com
 CE marked

Main Only



8604/8605/8606*/8607*

* 230 Volt (typical for European applications)

120 VOLT		AC Main Only Rocker Circuit Breaker Panels							
PN	Description	Width in" (mm)	Height in" (mm)	Weight Lb (Kg)	Installed Double Pole Circuit Breakers				
					16A	30A	32A	50A	
8604	Main Only	3.75 (95.25)	2.63 (66.68)	0.51 (0.23)	-	1	-	-	
8605	Main Only	3.75 (95.25)	2.63 (66.68)	0.51 (0.23)	-	-	-	1	

230 VOLT		AC Main Only Rocker Circuit Breaker Panels (Typical of Europe)							
PN	Description	Width in" (mm)	Height in" (mm)	Weight Lb (Kg)	Installed Double Pole Circuit Breakers				
					16A	30A	32A	50A	
8606	Main Only	3.75 (95.25)	2.63 (66.68)	0.51 (0.23)	1	-	-	-	
8607	Main Only	3.75 (95.25)	2.63 (66.68)	0.51 (0.23)	-	-	1	-	

AC MAIN POWER DISTRIBUTION AND CIRCUIT PROTECTION

▶ Available with white or black circuit breakers installed.

Source Selection Toggle Circuit Breaker Panels

- Provides source selection and circuit protection in one unit
- Pairs of double pole AC main circuit breakers with lockout slide
- All hot, neutral and safety ground buses installed, fully pre-wired
- Allows connecting one of multiple different AC sources to one circuit
- Prevents connecting both AC sources simultaneously
- Red reverse polarity LED indicators
- Green power available LED indicators
- Label backlighting pre-installed

2 Sources



8032/8061/8132*/8161*
3032/3061/3132*/3161*

3 Sources - Horizontal



8498/8598* 3498/3598*

3 Sources - Vertical



8495/8595* 3495/3595*

* 230 Volt
(typical for European applications)

120 VOLT		AC Toggle Source Selection Panels							
PN	PN	Description	Height in" (mm)	Width in" (mm)	Weight Lb (Kg)	Installed Double Pole Circuit Breakers			
						16A	30A	32A	50A
8032	3032	2 Sources	3.75 (95.25)	5.25 (133.35)	1.84 (0.83)	-	2	-	-
8061	3061	2 Sources	3.75 (95.25)	5.25 (133.35)	1.84 (0.83)	-	-	-	2
8498	3498	3 Sources - Horizontal	4.50 (114.30)	10.50 (266.70)	3.68 (1.67)	-	3	-	1
8495	3495	3 Sources - Vertical	7.50 (190.50)	5.25 (133.35)	3.68 (1.67)	-	3	-	1

230 VOLT		AC Toggle Source Selection Panels (Typical of Europe)							
PN	PN	Description	Height in" (mm)	Width in" (mm)	Weight Lb (Kg)	Installed Double Pole Circuit Breakers			
						16A	30A	32A	50A
8132	3132	2 Sources	3.75 (95.25)	5.25 (133.35)	1.84 (0.83)	2	-	-	-
8161	3161	2 Sources	3.75 (95.25)	5.25 (133.35)	1.84 (0.83)	-	-	2	-
8598	3598	3 Sources - Horizontal	4.50 (114.30)	10.50 (266.70)	3.68 (1.67)	3	-	1	-
8595	3595	3 Sources - Vertical	7.50 (190.50)	5.25 (133.35)	3.68 (1.67)	3	-	1	-

▶ See pages 78, 79, 84 for full sized panels with embedded lockout systems.

2 Sources



8600/8602*

* 230 Volt (typical for European applications)

Source Selection Rocker Circuit Breaker Panels

- Provides source selection and circuit protection in one unit
- Two double pole AC main circuit breakers with lockout slide
- All hot, neutral and safety ground buses installed, fully pre-wired
- Allows connecting one of two different AC sources to one circuit
- Prevents connecting both AC sources simultaneously
- Red reverse polarity LED indicator
- Green power available LED indicators
- Label backlighting pre-installed

120 VOLT		AC Rocker Source Selection Panels						
	Description	Height in" (mm)	Width in" (mm)	Weight Lb (Kg)	Installed Double Pole Circuit Breakers			
					16A	30A	32A	50A
8600	2 Sources	4.25 (107.95)	5.25 (133.35)	1.84 (0.83)	-	2	-	-

230 VOLT		AC Rocker Source Selection Panels (Typical of Europe)						
	Description	Height in" (mm)	Width in" (mm)	Weight Lb (Kg)	Installed Double Pole Circuit Breakers			
					16A	30A	32A	50A
8602	2 Sources	4.25 (107.95)	5.25 (133.35)	1.84 (0.83)	2	-	-	-

Specifications subject to change. See www.blueseas.com for current information.

32 Ampere 2 Positions + OFF, 2 Pole

Rotary Switch

- Switches 2 - 120 or 230 Volt AC Sources
- Compact solution when circuit protection is provided elsewhere
- Allows connecting one of two different AC sources to one circuit
- Mounts in panels up to 0.16" (4.00mm) thick
- Heavy duty industrial rated switch
- Intuitive function - One hand operation
- UL listed

Rotary Switch Panel

- **8367** Switches 2 - 120 Volt AC Sources
- **8359** Switches 2 - 230 Volt AC Sources
- Includes 9009 heavy duty industrial rated switch
- Two-part polyurethane slate gray finish
- Heavy 1/8" aluminum 5052 alloy
- Red reverse polarity LED indicators
- Green power available LED indicators

Specifications

Maximum Amperage 32 Amperes AC
 Maximum Voltage 600 Volts AC

PN	Description	Voltage	Mounting Depth in" (mm)	Width in" (mm)	Height in" (mm)
9009	Rotary Switch	600V Max.	1.91 (48.60)	1.89 (48.00)	1.89 (48.00)
8367	Switch Panel	120V	1.91 (48.60)	5.25 (133.35)	3.75 (95.25)
8359	Switch Panel	230V	1.91 (48.60)	5.25 (133.35)	3.75 (95.25)



9009 Front



9009 Side



8367/8359

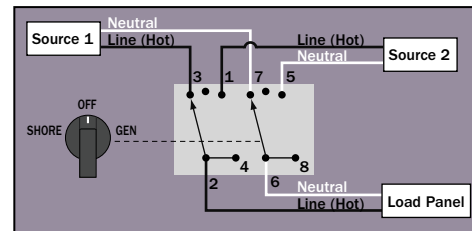

AC MAIN POWER DISTRIBUTION AND CIRCUIT PROTECTION

65 Ampere 2 Positions + OFF, 2 Pole

Rotary Switch

- Switches 2 - 120 or 230 Volt AC Sources
- Compact solution when circuit protection is provided elsewhere
- Allows connecting one of two different AC sources to one circuit
- Mounts in panels up to 0.16" (4.00mm) thick
- Heavy duty industrial rated switch
- Intuitive function - One hand operation
- UL listed

Rotary Switch Panel

- **8365** Switches 2 - 120 Volt AC Sources
- **8357** Switches 2 - 230 Volt AC Sources
- Includes 9011 heavy duty industrial rated switch
- Two-part polyurethane slate gray finish
- Heavy 1/8" aluminum 5052 alloy
- Red reverse polarity LED indicators
- Green power available LED indicators

Specifications

Maximum Amperage 65 Amperes AC
 Maximum Voltage 600 Volts AC

PN	Description	Voltage	Mounting Depth in" (mm)	Width in" (mm)	Height in" (mm)
9011	Rotary Switch	600V Max.	2.41 (61.21)	2.52 (64.00)	2.52 (64.00)
8365	Switch Panel	120V	2.41 (61.21)	5.25 (133.35)	3.75 (95.25)
8357	Switch Panel	230V	2.41 (61.21)	5.25 (133.35)	3.75 (95.25)



9011 Front



9011 Side



8365/8357

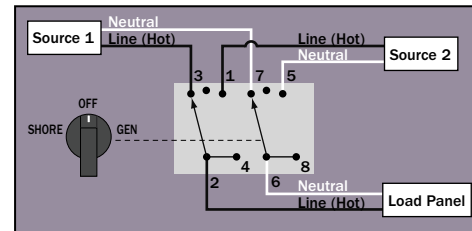



9019 Front



9019 Side



8363

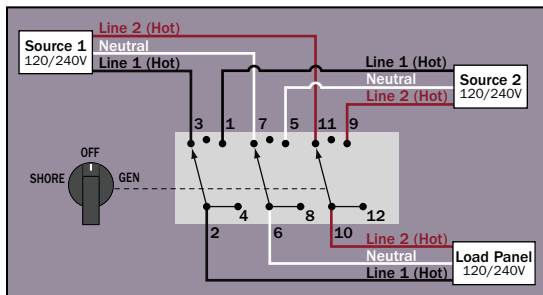

65 Ampere 2 Positions + OFF, 3 Pole

Rotary Switch

- Switches 2 - 120/240 Volt AC Sources
- Switches both lines (hot) and neutral
- Compact solution when circuit protection is provided elsewhere
- Allows connecting one of two different AC sources to one circuit
- Mounts in panels up to 0.16" (4.00mm) thick
- Heavy duty industrial rated switch
- Intuitive function - One hand operation
- UL listed

Rotary Switch Panel

- Switches 2 - 120/240 Volt AC Sources
- Includes 9019 heavy duty industrial rated switch
- Two-part polyurethane slate gray finish
- Heavy 1/8" aluminum 5052 alloy
- Red reverse polarity LED indicators
- Green power available LED indicators

Specifications

Maximum Amperage 65 Amperes AC
 Maximum Voltage 600 Volts AC

PN	Description	Voltage	Mounting Depth in" (mm)	Width in" (mm)	Height in" (mm)
9019	Rotary Switch	600V Max.	3.65 (92.78)	2.52 (64.00)	2.52 (64.00)
8363	Switch Panel	120/240V	3.65 (92.78)	5.25 (133.35)	3.75 (95.25)

NEW PRODUCT



6337 Front



6337 Side



9093 Front



9093 Side

NEW PRODUCT



8386



8369

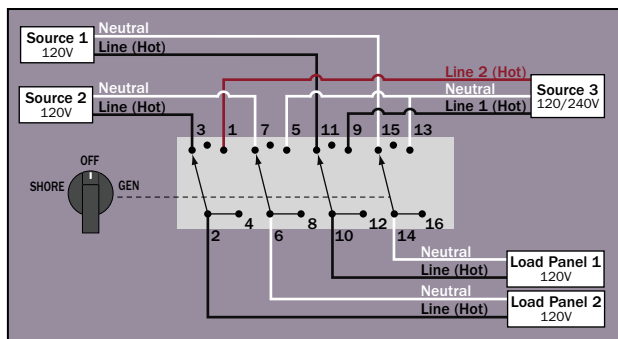

30 and 65 Ampere 2 Positions + OFF, 4 Pole

Rotary Switch

- Switches between 2 - 120 Volt AC shore power sources and 1 - 240 Volt AC source to 2 - 120 Volt AC load groups
- Switches both lines (hot) and neutral
- Compact solution when circuit protection is provided elsewhere
- Allows connecting one of two different AC sources to one circuit
- Mounts in panels up to 0.16" (4.00mm) thick
- Heavy duty industrial rated switch
- Intuitive function - One hand operation
- UL listed

Rotary Switch Panel

- Switches between 2 - 120 Volt AC shore power sources and 1 - 240 Volt AC source to 2 - 120 Volt AC load groups
- **8386** - Includes 6337 heavy duty industrial rated switch
- **8369** - Includes 9093 heavy duty industrial rated switch
- Two-part polyurethane slate gray finish
- Heavy 1/8" aluminum 5052 alloy
- Red reverse polarity LED indicators
- Green power available LED indicators

Specifications

Maximum Amperage **6337/8386** - 30 Amperes AC
9093/8369 - 65 Amperes AC
 Maximum Voltage 600 Volts AC

PN	Description	Voltage	Mounting Depth in" (mm)	Width in" (mm)	Height in" (mm)
6337	Rotary Switch	600V Max.	2.98 (75.69)	1.89 (48.00)	1.89 (48.00)
9093	Rotary Switch	600V Max.	4.50 (114.30)	2.52 (64.00)	2.52 (64.00)
8386	Switch Panel	120V	2.98 (75.69)	5.25 (133.35)	3.75 (95.25)
8369	Switch Panel	120V	4.50 (114.30)	5.25 (133.35)	3.75 (95.25)

NEW PRODUCT

32 Ampere 3 Positions + OFF, 2 Pole

Rotary Switch

- Switches 3 - 120 or 230 Volt AC Sources
- Compact solution when circuit protection is provided elsewhere
- Allows connecting three different AC sources to one circuit
- Mounts in panels up to 0.16" (4.00mm) thick
- Heavy duty industrial rated switch
- Intuitive function - One hand operation
- UL listed



9010 Front



9010 Side

Rotary Switch Panel

- **8366** - Switches 3 - 120 Volt AC Sources
- **8358** - Switches 3 - 230 Volt AC Sources
- Includes 9010 heavy duty industrial rated switch
- Two-part polyurethane slate gray finish
- Heavy 1/8" aluminum 5052 alloy
- Red reverse polarity LED indicators
- Green power available LED indicators



8366/8358

Specifications

Maximum Amperage 32 Amperes AC
Maximum Voltage 600 Volts AC

PN	Description	Voltage	Mounting Depth in" (mm)	Width in" (mm)	Height in" (mm)
9010	Rotary Switch	600V Max.	2.41 (61.21)	1.89 (48.00)	1.89 (48.00)
8366	Switch Panel	120V	2.41 (61.21)	5.25 (133.35)	3.75 (95.25)
8358	Switch Panel	230V	2.41 (61.21)	5.25 (133.35)	3.75 (95.25)

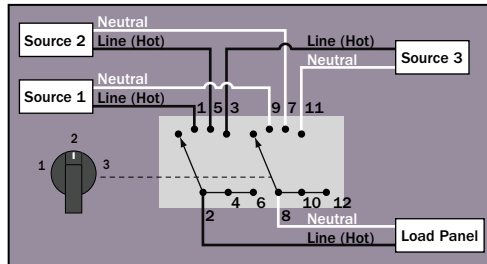

65 Ampere 3 Positions + OFF, 3 Pole

Rotary Switch

- Switches 3 - 120/240 Volt AC Sources
- Switches both lines (hot) and neutral
- Compact solution when circuit protection is provided elsewhere
- Allows connecting one of three different AC sources to one circuit
- Mounts in panels up to 0.16" (4.00mm) thick
- Heavy duty industrial rated switch
- Intuitive function - One hand operation
- UL listed



9077 Front



9077 Side

Rotary Switch Panel

- Switches 3 - 120/240 Volt AC Sources
- Includes 9077 heavy duty industrial rated switch
- Two-part polyurethane slate gray finish
- Heavy 1/8" aluminum 5052 alloy
- Red reverse polarity LED indicators
- Green power available LED indicators



8361

Specifications

Maximum Amperage 65 Amperes AC
Maximum Voltage 600 Volts AC

PN	Description	Voltage	Mounting Depth in" (mm)	Width in" (mm)	Height in" (mm)
9077	Rotary Switch	600V Max.	5.50 (139.70)	2.52 (64.00)	2.52 (64.00)
8361	Switch Panel	120/240V	5.50 (139.70)	5.25 (133.35)	3.75 (95.25)

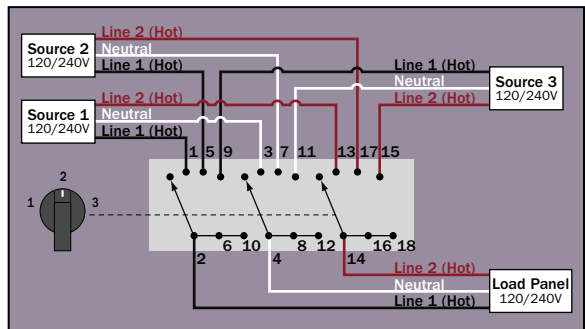

The AC Branch Power System begins at the Line terminal connection of the AC branch circuit breaker for the Hot wire and at the branch circuit connection block for the neutral and safety ground wires. It ends at the AC outlet or the AC device that is powered. The devices used for AC branch power distribution are the same devices used for AC branch circuit protection. For this reason these two product areas are combined into AC branch power systems in this section of the catalog.

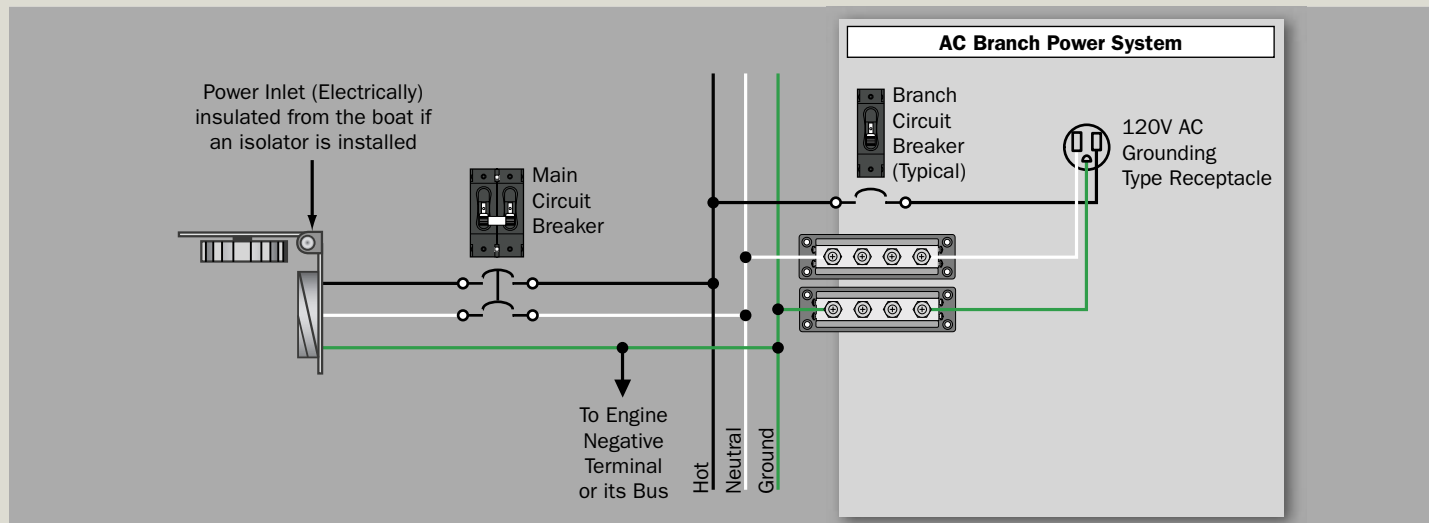

Purpose

- Distribution of high amperage currents from a single cable into lower amperages in multiple wires
- Circuit protection
- Switching
- GFCI (see page 122) in North American systems

System Configurations - Physical configuration of AC Branch circuit breakers

Circuit breakers used for AC branch switching and circuit protection always have one pole less than the AC main installed between the branch circuit breaker and the AC power source. This circuit breaker is installed in the AC hot conductor.

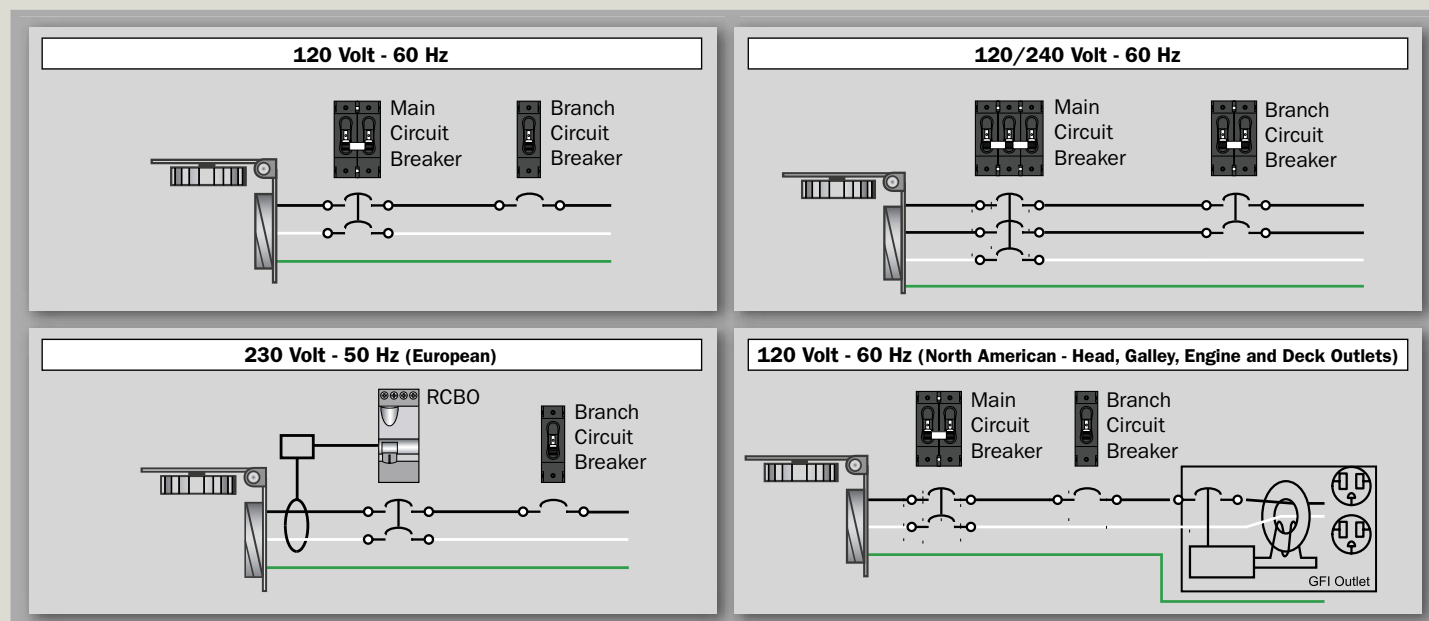

The Devices

AC branch circuit breakers are distinguished by their AIC rating. The table on the right shows the AIC required in AC branch circuit breakers for each type of shore power commonly found in marinas.

As it is only in 120 Volt and 120/240 Volt systems that AC main circuit and AC branch circuit requirements differ, the same circuit breakers that are used in AC main systems are used in AC branch applications. It is only in the number of poles that main and branch circuit breakers differ (See page 62 for Selecting AC Circuit Protection).

Ampere Interrupt Rating - ABYC Table

AC Shore Power Source	Main Circuit Breaker	Branch Circuit Breaker
120V - 30A	3,000	3,000
120V - 50A	3,000	3,000
120/240V - 50A	5,000	3,000
240V - 50A	5,000	3,000

Single and Double Pole Toggle World Circuit Breakers

The World Circuit Breaker meets all American Boat and Yacht Council (ABYC) standards, is UL 1077 recognized, TUV certified, CE marked for Europe, and CSA certified for Canada.

- The industry standard circuit breaker for Blue Sea Systems electrical panels
- Combines switching and circuit protection into a single device
- Double pole used as 120/240 Volt AC branch circuit breakers to switch line 1 and line 2
- "Trip Free" design cannot be held "ON" during fault current condition
- For circuit breaker mounting panels (see page 87)

Specifications

Circuit Breaker Type	Magnetic Hydraulic - Trip free
Maximum Amperage	50 Amperes
Maximum Voltage	277 Volts AC/65 Volts DC
Rated Switch Cycles	10,000@rated amperage and voltage
Delay	See www.bluesea.com
Weight	Single Pole 0.17Lb (0.08Kg) Double Pole 0.34Lb (0.15Kg)
Mounting screw	#6-32
Terminal screw	#10-32 SS with external tooth lockwasher

CE marked

Interrupt Ratings (see ABYC Interrupt rating Requirements page 71)

World Circuit Breakers - Single and Double Pole			
Voltage	Current	Interrupt Ratings	Interrupt Ratings
		UL 1077 - UL/CSA (US/Canada) ¹	EN60934 - TUV (Europe)
65V DC	5-50A	7,500A	1,500A
120V AC	5-50A	3,000A	1,500A
120/240V AC	10-50A	3,000A	1,500A
250V AC	10-50A	3,000A	1,500A

¹ UL Recognized



7200



7233

AC BRANCH POWER DISTRIBUTION AND CIRCUIT PROTECTION

Single Pole		
PN	Color	Amperage
7200	Black	5A
7201	Red	5A
7202	White	5A
7347	Black	8A
7299	White	8A
7204	Black	10A
7205	Red	10A
7206	White	10A
7208	Black	15A
7209	Red	15A
7210	White	15A
7212	Black	20A
7213	Red	20A
7214	White	20A
7216	Black	25A
7217	Red	25A

Single Pole		
PN	Color	Amperage
7218	White	25A
7220	Black	30A
7221	Red	30A
7222	White	30A
7224	Black	40A
7225	Red	40A
7226	White	40A
7228	Black	50A
7229	Red	50A
7230	White	50A

Double Pole		
PN	Color	Amperage
7232	Black	10A
7233	White	10A
7234	Black	15A
7235	White	15A
7348	Black	16A
7294	White	16A
7236	Black	20A
7260	White	20A
7237	Black	30A
7238	White	30A
7349	Black	32A
7295	White	32A
7239	Black	40A
7240	White	40A
7241	Black	50A
7242	White	50A

NEW PRODUCT

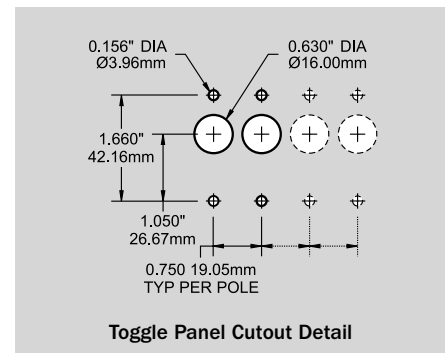
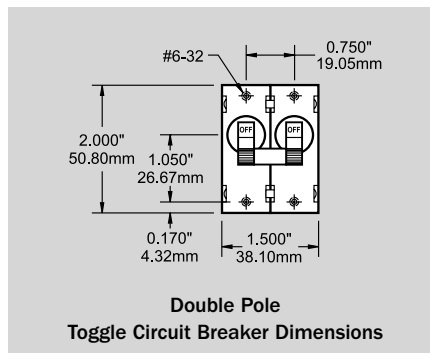
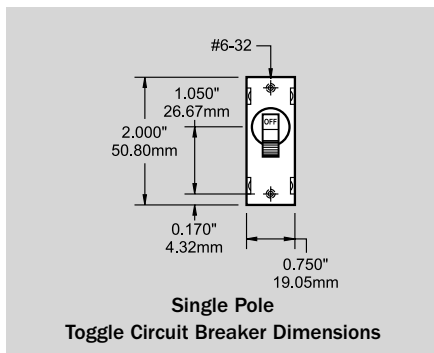



7300



7320

AIRPAX

Single and Double Pole Small Case 2” Rocker Circuit Breakers

- Rocker actuator gives modern appearance to electrical distribution panels
- Dual color rocker gives clear visual indication of handle position
- Double pole used as 120/240 Volt AC branch circuit breakers to switch line 1 and line 2
- “Trip Free” design cannot be held “ON” during fault current condition

Specifications

Circuit Breaker Type Magnetic Hydraulic - Trip free
 Maximum Amperage See table below
 Maximum Voltage See table below
 Rated Switch Cycles 10,000@rated amperage and voltage
 Delay See www.bluesea.com
 Weight Single Pole 0.19Lb (0.09Kg)
 Double Pole 0.36Lb (0.16Kg)
 Mounting screw #6-32
 Terminal screw #10-32 SS with external tooth lockwasher
CE marked

Interrupt Ratings (see ABYC Interrupt rating Requirements page 71)

Rocker Circuit Breakers - Single and Double Pole			
		UL 1077 - UL/CSA (US/Canada) ¹	EN60934 - VDE (Europe)
Voltage	Current	Interrupt Ratings	Interrupt Ratings
65V DC	5-50A	-	2,000A
80V DC	5-30A	-	4,000A
80V DC	5-50A	7,500A	-
125V AC	5-50A	3,000A	-
240V AC	5-50A	2,000A	-
250V AC	5-30A	2,000A	2,000A
250V AC	5-50A	-	2,000A

¹ UL Recognized

PN	Pole	Amperage	PN	Pole	Amperage	PN	Pole	Amperage
7300	1	5A	7306	1	30A	7303	1	15A
7301	1	8A	7307	1	40A	7304	1	20A
7302	1	10A	7308	1	50A	7305	1	25A
7303	1	15A	7300	1	5A	7306	1	30A
7304	1	20A	7301	1	8A	7307	1	40A
7305	1	25A	7302	1	10A	7308	1	50A
						7320	2	10A
						7321	2	15A
						7322	2	16A
						7323	2	20A
						7324	2	30A
						7325	2	32A
						7326	2	40A
						7327	2	50A
4110	-	-		-	-		-	Panel Plug Kit

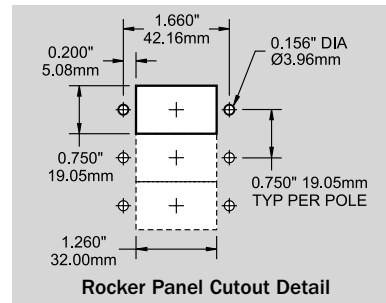
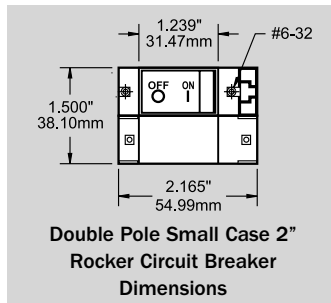
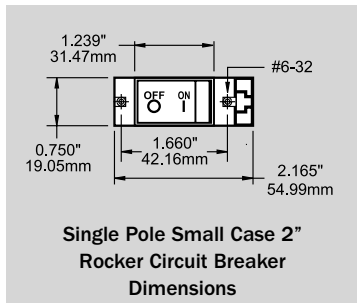

7408



7433

AIRPAX

Single Pole Small Case 2” Rocker Circuit Breakers NEW PRODUCT

- Color actuator indicates “OFF” position
- “Trip Free” design cannot be held “ON” during fault current condition
- 2 different actuator styles available to protect accidental switching

Specifications

Circuit Breaker Type Magnetic Hydraulic - Trip free
 Maximum Amperage See tables below
 Maximum Voltage See tables below
 Rated Switch Cycles 10,000@rated amperage and voltage
 Delay See www.bluesea.com
 Mounting screw #6-32 SS - Recommended torque 6-8 in-lb
 Terminal screw 45° Angled #10-32 x 5/16 SS SEM external tooth lock washer
 - Recommended torque 14-15 in-lb

CE marked

▶ See page 42 for more details

Interrupt Ratings (see ABYC Interrupt rating Requirements page 71)

Small Case IEGBX Rocker Circuit Breakers - Single Pole			
		UL 1077 - UL/CSA (US/Canada) ¹	EN60934 - VDE (Europe)
Voltage	Current	Interrupt Ratings	Interrupt Ratings
65V DC	5-50A	-	2,000A
80V DC	5-30A	-	4,000A
80V DC	5-50A	7,500A	-
125V AC	5-50A	3,000A	-
240V AC	5-50A	2,000A	-
250V AC	5-30A	2,000A	2,000A
250V AC	5-50A	-	2,000A

¹ UL Recognized

PN	Actuator	Poles	Amperage	PN	Actuator	Poles	Amperage
7400	Flat	1	5A	7425	Slot Reset	1	5A
7401	Flat	1	8A	7426	Slot Reset	1	8A
7402	Flat	1	10A	7427	Slot Reset	1	10A
7403	Flat	1	15A	7428	Slot Reset	1	15A
7404	Flat	1	20A	7429	Slot Reset	1	20A
7405	Flat	1	25A	7430	Slot Reset	1	25A
7406	Flat	1	30A	7431	Slot Reset	1	30A
7407	Flat	1	40A	7432	Slot Reset	1	40A
7408	Flat	1	50A	7433	Slot Reset	1	50A

NEW PRODUCT

C-Series Circuit Breakers

- 5,000 Ampere interrupt capacity to meet ABYC requirements for 120/240 Volt AC 50 Ampere main protection
- Double pole can be used as 120 Volt AC main circuit breaker to switch line 1 and line 2
- Triple pole can be used as 240 Volt AC main circuit breaker to switch line 1 and line 2
- Double and triple pole circuit breakers will trip all poles if any one pole trips
- "Trip Free" design cannot be held "ON" during fault current condition

Specifications

Circuit Breaker Type Magnetic Hydraulic - Trip free
 Maximum Amperage 100 Amperes
 Maximum Voltage 250 Volts AC
 Delay See www.blueseas.com

PN	Color	Poles	Amperage	Weight Lb (Kg)
7350	White	1*	5A	0.28 (0.13)
7351	White	1*	10A	0.28 (0.13)
7352	White	1*	15A	0.28 (0.13)
7353	White	1*	20A	0.28 (0.13)
7354	White	1*	25A	0.28 (0.13)
7355	White	1*	30A	0.28 (0.13)
7244	White	1*	50A	0.36 (0.17)
7246	White	1*	60A	0.36 (0.17)
7248	White	1*	80A	0.36 (0.17)
7250	White	1*	100A	0.36 (0.17)
7365	White	2	30A	0.56 (0.26)
7251	White	2	50A	0.56 (0.26)
7254	White	2	60A	0.56 (0.26)
7256	White	2	80A	0.56 (0.26)
7258	White	2	100A	0.56 (0.26)
7287	White	3	50A	0.93 (0.46)
7288	White	3	60A	0.93 (0.46)
7289	White	3	80A	0.93 (0.46)
7290	White	3	100A	0.93 (0.46)

* Single pole breakers are AC/DC rated

▶ See page 65 for C-Series Circuit Breaker Mounting Panels.



7250

7251



7287

Interrupt Ratings (see ABYC Interrupt Rating Requirements page 71)

C-Series Circuit Breakers - Single Pole			
		UL 1077 - UL/CSA (US/Canada) ¹	EN60934 - TUV (Europe)
Voltage	Current	Interrupt Ratings	Interrupt Ratings
80V DC	5-100A	10,000A	5,000A
125V AC	5-100A	5,000A	5,000A
250V AC	5-100A	5,000A	5,000A

¹ UL Recognized

C-Series Circuit Breakers - Double and Triple Pole			
		UL 1077 - UL/CSA (US/Canada) ¹	EN60934 - TUV (Europe)
Voltage	Current	Interrupt Ratings	Interrupt Ratings
125/250V AC	50-100A	5,000A	5,000A
250V AC	50-100A	5,000A	5,000A

¹ UL Recognized

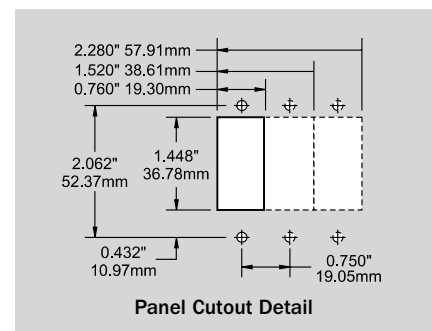
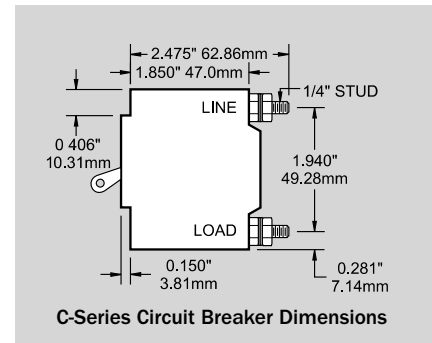
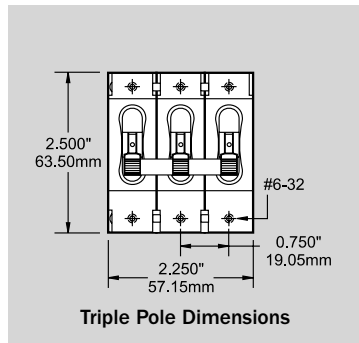
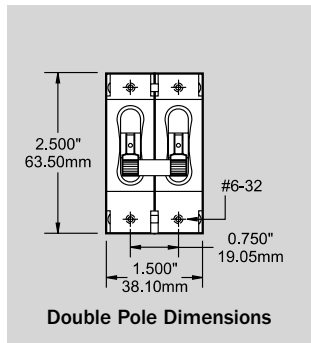
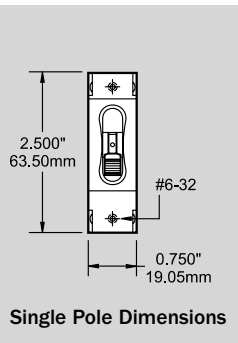

AC Rocker and Toggle Panels

Common Features

- MIL-C-5541C or equivalent immersion undercoating for lifetime corrosion resistance
- All circuit label positions are backlit on standard panels - No kit required
- "ON" indicating LEDs installed in all circuit positions
- Countersunk mounting holes throughout
- Two-part polyurethane slate gray finish
- Heavy 1/8" aluminum 5052 alloy
- Industry standard height and width
- Over 500 individual labels to choose from (see pages 91-94)

Tin-Plated Copper bussing for high conductivity



AC Toggle style Circuit Breaker Panels are now available with black World Magnetic Circuit Breakers (see pages 78-85)

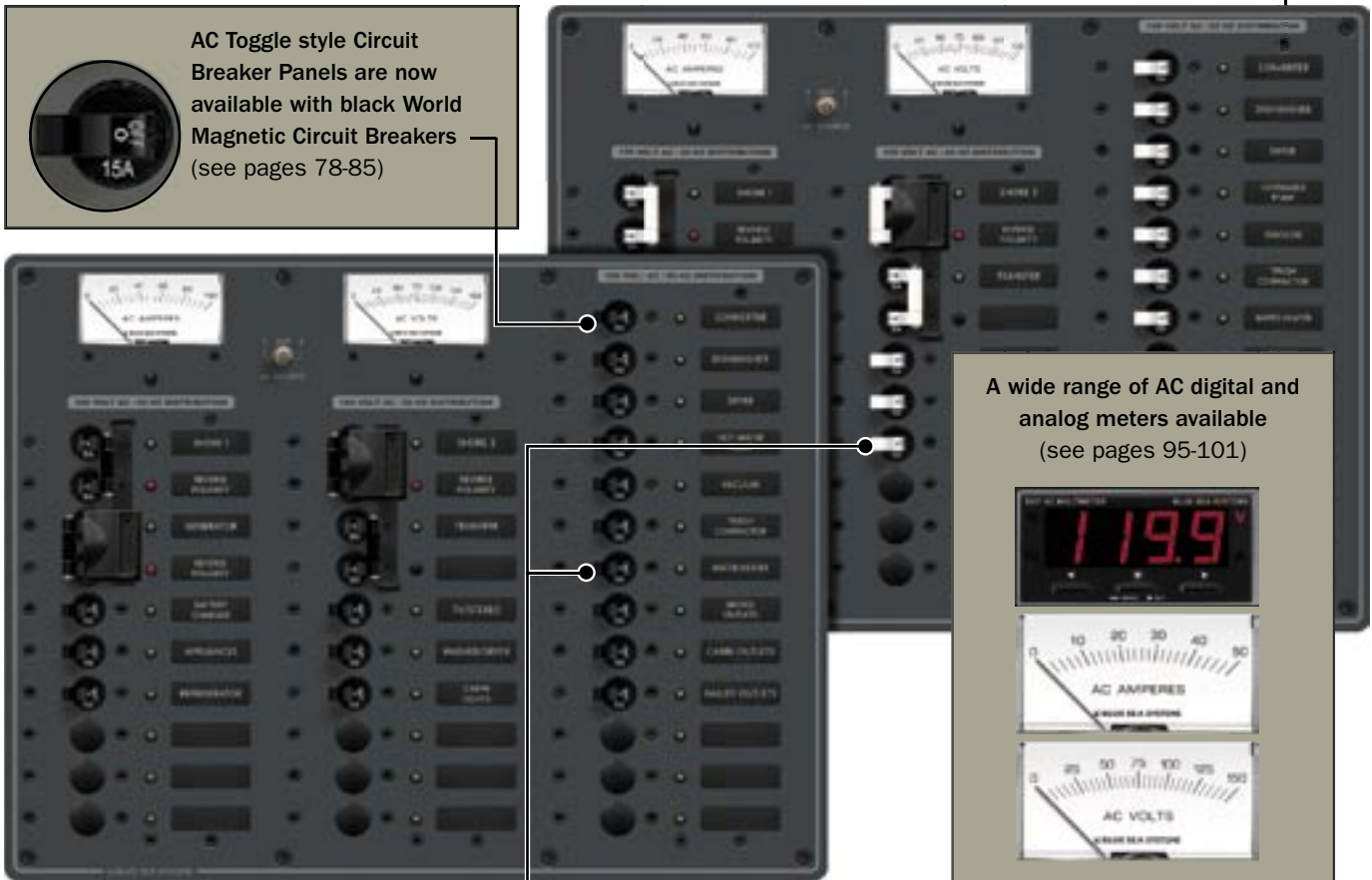

A wide range of AC digital and analog meters available (see pages 95-101)

Industry standard, toggle style, World Magnetic Circuit Breakers available in white or black (see pages 41, 63, and 72)



Rocker style Magnetic Circuit Breakers offer modern styling and improved resistance to accidental switching (see pages 43, 64, 73)



AC BRANCH POWER DISTRIBUTION AND CIRCUIT PROTECTION

AC Rocker Circuit Breaker Panels

Common Features

- Panels with a Main Circuit Breaker have a red reverse polarity LED indicator
- All hot, neutral, and safety ground buses installed, fully pre-wired
- Includes set of 30 common AC labels (see page 90)
- Label backlighting pre-installed excluding AC Main Only panels
- All LEDs installed

Main + 8 Positions



8620/8621*

Main + 3 Positions



8618/8619*

Main + 6 Positions



8616/8617*

8 Position



8612/8613*

Main Only¹



8604/8605/8606*/8607*

Main + 1 Position¹



8614/8615*

3 Position



8610/8611*

* 230 Volt (typical of Europe)

120 VOLT AC Rocker Circuit Breaker Panels												
PN	Description	Meter Type/PN	Meter Page	Width in" (mm)	Height in" (mm)	Weight Lb (Kg)	Installed Double Pole Circuit Breaker				Installed Single Pole Circuit Breakers	
							16A	30A	32A	50A	8A	15A
8604	Main only ¹	-	-	3.75 (95.25)	2.63 (66.68)	0.51 (0.23)	-	1	-	-	-	-
8605	Main only ¹	-	-	3.75 (95.25)	2.63 (66.68)	0.51 (0.23)	-	-	-	1	-	-
8614	Main + 1 Position ¹	-	-	5.25 (133.35)	3.75 (95.25)	0.95 (0.43)	-	1	-	-	-	-
8618	Main + 3 Positions	Digital/8247	96	5.25 (133.35)	7.50 (190.50)	2.94 (1.33)	-	1	-	-	-	3
8616	Main + 6 Positions	-	-	5.25 (133.35)	7.50 (190.50)	1.87 (0.85)	-	1	-	-	-	3
8620	Main + 8 Positions	Digital/8247	96	5.25 (133.35)	11.25 (285.75)	3.18 (1.44)	-	1	-	-	-	5
8610	3 Position	-	-	5.25 (133.35)	3.75 (95.25)	1.14 (0.52)	-	-	-	-	-	3
8612	8 Position	-	-	5.25 (133.35)	7.50 (190.50)	1.85 (0.84)	-	-	-	-	-	5

230 VOLT AC Rocker Circuit Breaker Panels (Typical of Europe)												
PN	Description	Meter Type/PN	Meter Page	Width in" (mm)	Height in" (mm)	Weight Lb (Kg)	Installed Double Pole Circuit Breaker				Installed Single Pole Circuit Breakers	
							16A	30A	32A	50A	8A	15A
8606	Main only ¹	-	-	3.75 (95.25)	2.63 (66.68)	0.51 (0.23)	1	-	-	-	-	-
8607	Main only ¹	-	-	3.75 (95.25)	2.63 (66.68)	0.51 (0.23)	-	-	1	-	-	-
8615	Main + 1 Position ¹	-	-	5.25 (133.35)	3.75 (95.25)	0.95 (0.43)	1	-	-	-	-	-
8619	Main + 3 Positions	Digital/8247	96	5.25 (133.35)	7.50 (190.50)	2.94 (1.33)	1	-	-	-	3	-
8617	Main + 6 Positions	-	-	5.25 (133.35)	7.50 (190.50)	1.87 (0.85)	1	-	-	-	3	-
8621	Main + 8 Positions	Digital/8247	96	5.25 (133.35)	11.25 (285.75)	3.18 (1.44)	1	-	-	-	5	-
8611	3 Position	-	-	5.25 (133.35)	3.75 (95.25)	1.14 (0.52)	-	-	-	-	3	-
8613	8 Position	-	-	5.25 (133.35)	7.50 (190.50)	1.85 (0.84)	-	-	-	-	5	-

¹ Includes labels illustrated only

Blue Sea Systems 11-1/4" height 240 Volt AC Distribution Panels are designed as companion panels to the 11-1/4" height 120 Volt AC panels.



The 240 Volt AC Distribution Panel supplies main circuit protection, AC source management, 240 Volt AC metering and 240 Volt AC branch circuits. Each 120 Volt AC leg from the 240V AC Distribution Panel is wired to the 120 Volt AC Distribution Panel powering the 120 Volt AC branch circuits.

120/240 Volt AC Circuit Breaker Panels

Common Features

- Red reverse polarity indicating LED
- All hot, neutral, and safety ground buses installed, fully pre-wired
- Label backlighting pre-installed
- All LEDs installed
- Maximum panel amperage - 50 Amperes

Main Only



7372

Source Selector + 2 Positions



7374

Source Selector + 2 Positions



7373

AC Main + 3 Positions



7370

AC Main + 3 Positions



7371

240 VOLT		AC Main Only Circuit Breaker Panel					
PN	Description	Meter Type/PN	Meter Page	Width in" (mm)	Height in" (mm)	Weight Lb (Kg)	Installed C-Series 3 Pole Main
7372	Main Only	-	-	5.25 (133.35)	3.75 (95.30)	1.38 (0.63)	50A 1

120/240 VOLT		AC Main and Source Selection Circuit Breaker Panels					
PN	Description	Meter Type/PN	Meter Page	Width in" (mm)	Height in" (mm)	Weight Lb (Kg)	Installed C-Series 3 Pole Main
7370	Main + 3 Positions	Analog/9354	100	5.25 (133.35)	11.25 (285.75)	2.98 (1.35)	50A 1
7371	Main + 3 Positions	Digital/8247	96	5.25 (133.35)	11.25 (285.75)	3.37 (1.53)	50A 1
7374	Source Selector + 2 Positions	Analog/9354	100	5.25 (133.35)	11.25 (285.75)	3.70 (1.68)	50A 2
7373	Source Selector + 2 Positions	Digital/8247	96	5.25 (133.35)	11.25 (285.75)	4.09 (1.85)	50A 2

AC Source Selector Circuit Breaker Panels

▶ Available with white or black circuit breakers installed. 

Common Features

- Red reverse polarity indication LED
- Double pole AC main circuit breakers with installed lockout slides
- All hot, neutral, and safety ground buses installed, fully pre-wired
- Includes set of 30 common AC labels (see page 90)
- Prevent connecting multiple AC sources simultaneously
- Label backlighting pre-installed
- All LEDs installed
- Maximum panel amperage - 50 Amperes

2 Sources + 32 Positions



8476/8576*   3476/3576*  

3 Sources + 25 Positions



8494/8594*   3494/3594*  

2 Sources + 18 Positions



8458   3458  

2 Sources + 29 Positions



8477/8577*   3477/3577*  

2 Sources + 20 Positions



8469/8569*   3469/3569*  

2 Sources + 12 Positions



8468/8568*   3468/3568*  

2 Sources + 17 Positions



8475/8575*   3475/3575*  

2 Sources + 9 Positions



8462/8562*   3462/3562*  

3 Sources + 28 Positions



8496/8596*   3496/3596*  

2 Sources + 14 Positions



8473/8573*   3473/3573*  

3 Sources - Horizontal¹



8498/8598*   3498/3598*  

2 Sources + 8 Positions



8459/8559*   3459/3559*  

2 Sources + 4 Positions



8499/8599*   3499/3599*  

¹ Includes labels illustrated only
* 230 Volt (typical of Europe)

2 Sources + 9 Positions



8466/8566*
3466/3566*

2 Sources + 6 Positions



8489/8589*
3489/3589*

3 Sources - Vertical¹



8495/8595*
3495/3595*

3 Sources + 2 Positions¹



8474/8574*
3474/3574*

2 Sources + 4 Positions



8467/8567*
3467/3567*

2 Sources¹



8032/8061/8132*/8161*
3032/3061/3132*/3161*

¹ Includes labels illustrated only
* 230 Volt (typical of Europe)

Use the tables below to select AC Distribution Panels with AC Source Selectors where multiple sources must be managed on the panel.

120 VOLT		AC Source Selector Circuit Breaker Panels								
PN	PN	Description	Meter Type/PN	Meter Page	Width in" (mm)	Height in" (mm)	Weight Lb (Kg)	Installed Double Pole Circuit Breakers		Installed Single Pole Circuit Breakers
								30A	50A	15A
8032	3032	2 Sources	-	-	5.25 (133.35)	3.75 (95.25)	1.84 (0.83)	2	-	-
8061	3061	2 Sources	-	-	5.25 (133.35)	3.75 (95.25)	1.84 (0.83)	-	2	-
8495	3495	3 Sources - Vertical	-	-	5.25 (133.35)	7.50 (190.50)	2.24 (1.00)	3	1	-
8498	3498	3 Sources - Horizontal	-	-	10.50 (266.70)	4.50 (114.30)	1.90 (0.86)	3	1	-
8474	3474	3 Sources + 2 Positions	-	-	5.25 (133.35)	7.50 (190.50)	1.90 (0.86)	3	-	-
8467	3467	2 Sources + 4 Positions	-	-	5.25 (133.35)	7.50 (190.50)	1.90 (0.86)	2	-	2
8499	3499	2 Sources + 4 Positions	-	-	10.50 (266.70)	4.50 (114.30)	1.90 (0.86)	2	-	2
8489	3489	2 Sources + 6 Positions	Analog/9353	100	5.25 (133.35)	11.25 (285.75)	3.00 (1.36)	2	-	3
8459	3459	2 Sources + 8 Positions	-	-	14.75 (374.65)	4.50 (114.30)	3.15 (1.43)	2	-	6
8466	3466	2 Sources + 9 Positions	-	-	5.25 (133.35)	11.25 (285.75)	2.81 (1.27)	2	-	6
8462	3462	2 Sources + 9 Positions	Analog/9353	100	10.50 (266.70)	7.50 (190.50)	3.80 (1.72)	2	-	6
8468	3468	2 Sources + 12 Positions	-	-	10.50 (266.70)	7.50 (190.50)	3.75 (1.70)	2	-	8
8473	3473	2 Sources + 14 Positions	Analog/9630, 9353	100	14.75 (374.65)	7.50 (190.50)	6.00 (2.72)	2	-	11
8475	3475	2 Sources + 17 Positions	Digital/8247	96	14.75 (374.65)	7.50 (190.50)	5.30 (2.40)	2	-	11
8458	3458	2 Sources + 18 Positions	Analog/9630, 9353	100	10.50 (266.70)	13.75 (349.25)	9.10 (4.12)	3	1	12
8469	3469	2 Sources + 20 Positions	-	-	14.75 (374.65)	7.50 (190.50)	5.30 (2.40)	2	-	14
8494	3494	3 Sources + 25 Positions	Analog/9630, 9353	100	14.75 (374.65)	11.25 (285.75)	9.00 (4.08)	3	1	16
8496	3496	3 Sources + 28 Positions	Digital/8247	96	14.75 (374.65)	11.25 (285.75)	10.10 (4.58)	3	1	19
8477	3477	2 Sources + 29 Positions	Analog/9630, 9353	100	14.75 (374.65)	11.25 (285.75)	9.20 (4.17)	2	-	20
8476	3476	2 Sources + 32 Positions	Digital/8247	96	14.75 (374.65)	11.25 (285.75)	10.30 (4.67)	2	-	23

230 VOLT		AC Source Selector Circuit Breaker Panels (Typical of Europe)								
PN	PN	Description	Meter Type/PN	Meter Page	Width in" (mm)	Height in" (mm)	Weight Lb (Kg)	Installed Double Pole Circuit Breakers		Installed Single Pole Circuit Breakers
								16A	32A	8A
8132	3132	2 Sources	-	-	5.25 (133.35)	3.75 (95.25)	1.84 (0.83)	2	-	-
8161	3161	2 Sources	-	-	5.25 (133.35)	3.75 (95.25)	1.84 (0.83)	-	2	-
8595	3595	3 Sources - Vertical	-	-	5.25 (133.35)	7.50 (190.50)	2.24 (1.00)	3	1	-
8598	3598	3 Sources - Horizontal	-	-	10.50 (266.70)	4.50 (114.30)	1.90 (0.86)	3	1	-
8574	3574	3 Sources + 2 Positions	-	-	5.25 (133.35)	7.50 (190.50)	1.90 (0.86)	3	-	-
8567	3567	2 Sources + 4 Positions	-	-	5.25 (133.35)	7.50 (190.50)	1.90 (0.86)	2	-	2
8599	3599	2 Sources + 4 Positions	-	-	10.50 (266.70)	4.50 (114.30)	1.90 (0.86)	2	-	2
8589	3589	2 Sources + 6 Positions	Analog/9354	100	5.25 (133.35)	11.25 (285.75)	3.00 (1.36)	2	-	3
8559	3559	2 Sources + 8 Positions	-	-	14.75 (374.65)	4.50 (114.30)	3.15 (1.43)	2	-	6
8566	3566	2 Sources + 9 Positions	-	-	5.25 (133.35)	11.25 (285.75)	2.81 (1.27)	2	-	6
8562	3562	2 Sources + 9 Positions	Analog/9354	100	10.50 (266.70)	7.50 (190.50)	3.80 (1.72)	2	-	6
8568	3568	2 Sources + 12 Positions	-	-	10.50 (266.70)	7.50 (190.50)	3.75 (1.70)	2	-	8
8573	3573	2 Sources + 14 Positions	Analog/9630, 9354	100	14.75 (374.65)	7.50 (190.50)	6.00 (2.72)	2	-	11
8575	3575	2 Sources + 17 Positions	Digital/8247	96	14.75 (374.65)	7.50 (190.50)	5.30 (2.40)	2	-	11
8569	3569	2 Sources + 20 Positions	-	-	14.75 (374.65)	7.50 (190.50)	5.30 (2.40)	2	-	14
8594	3594	3 Sources + 25 Positions	Analog/9630, 9354	100	14.75 (374.65)	11.25 (285.75)	9.00 (4.08)	3	1	16
8596	3596	3 Sources + 28 Positions	Digital/8247	96	14.75 (374.65)	11.25 (285.75)	10.10 (4.58)	3	1	19
8577	3577	2 Sources + 29 Positions	Analog/9630, 9354	100	14.75 (374.65)	11.25 (285.75)	9.20 (4.17)	2	-	20
8576	3576	2 Sources + 32 Positions	Digital/8247	96	14.75 (374.65)	11.25 (285.75)	10.30 (4.67)	2	-	23

AC Main Circuit Breaker Panels

▷ Available with white or black circuit breakers installed. 

Common Features

- Red reverse polarity indication LED
- All hot, neutral, and safety ground buses installed, fully pre-wired
- Includes set of 30 common AC labels (see page 90)
- Label backlighting pre-installed excluding AC Main Only panels
- All LEDs installed
- Maximum panel amperage - 50 Amperes

Main + 34 Positions



8487/8587*   3487/3587*  

AC Main + 31 Positions



8486/8586*   3486/3586*  

Main + 19 Positions



8472/8572*   3472/3572*  



Main + 16 Positions



8471/8571*   3471/3571*  





Main + 3 Positions



8405/8505*  





Main + 3 Positions



8409/8509*   3409/3509*  





Main + 3 Positions



8043/8143*   3043/3143*  

Main + 6 Positions



8027/8127*   3027/3127*  

Main + 22 Positions



8465/8565*   3465/3565*  

Main + 10 Positions



8463/8563*   3463/3563*  

Main + 11 Positions



8407/8507*   3407/3507*  

Main + 11 Positions



8076/8176*   3076/3176*  

Main + 11 Positions



8470/8570*   3470/3570*  

Main + 14 Positions



8464/8564*   3464/3564*  

Main + 6 Positions



8412/8512*   3412/3512*  





Main + 4 Positions



8099/8199*   3099/3199*  





Main + 8 Positions



8406/8506*   3406/3506*  





Main + 8 Positions



8488/8588*   3488/3588*  





Main + 11 Positions



8485/3485*   8585/3585*  





Main + 8 Positions



8074/8174*   3074/3174*  





Main + 1 Position¹



8029/8129*   3029/3129*  

Main Only¹



8077/8079/8177*/8179*   3077/3079/3177*/3179*  

¹ Includes labels illustrated only
* 230 Volt (typical of Europe)

Specifications subject to change. See www.blueseasystems.com for current information.

Use the tables below to select AC Distribution Panels with AC Main Circuit Breakers where a single AC electrical source is brought to the panel and AC Main Circuit Protection is required.

120 VOLT		AC Main Toggle Circuit Breaker Panels								
PN	PN	Description	Meter Type/PN	Meter Page	Width in" (mm)	Height in" (mm)	Weight Lb (Kg)	Installed Double Pole Circuit Breakers		Installed Single Pole Circuit Breakers
								30A	50A	15A
8077	3077	Main only	-	-	2.63 (66.68)	3.75 (95.25)	0.51 (0.23)	1	-	-
8079	3079	Main only	-	-	2.63 (66.68)	3.75 (95.25)	0.51 (0.23)	-	1	-
8029	3029	Main + 1 Position	-	-	5.25 (133.35)	3.75 (95.25)	0.95 (0.43)	1	-	-
8043	3043	Main + 3 Positions	Analog/9353	100	5.25 (133.35)	7.50 (190.50)	2.00 (0.91)	1	-	3
8409	3409	Main + 3 Positions	Analog/8246, 8244	100	5.25 (133.35)	7.50 (190.50)	4.06 (1.84)	1	-	3
8405	3405	Main + 3 Positions	Digital/8247	96	5.25 (133.35)	7.50 (190.50)	2.94 (1.33)	1	-	3
8099	3099	Main + 4 Positions	-	-	10.50 (266.70)	3.75 (95.25)	2.22 (1.00)	1	-	4
8027	3027	Main + 6 Positions	-	-	5.25 (133.35)	7.50 (190.50)	1.87 (0.85)	1	-	3
8412	3412	Main + 6 Positions	-	-	10.50 (266.70)	4.50 (114.30)	1.90 (0.86)	1	-	4
8488	3488	Main + 8 Positions	Analog/9353	100	5.25 (133.35)	11.25 (285.75)	3.00 (1.36)	1	-	5
8074	3074	Main + 8 Positions	Analog/8246, 8244	100	5.25 (133.35)	11.25 (285.75)	3.18 (1.44)	1	-	5
8406	3406	Main + 8 Positions	Digital/8247	96	5.25 (133.35)	11.25 (285.75)	3.18 (1.44)	1	-	5
8463	3463	Main + 10 Positions	-	-	14.75 (374.65)	4.50 (114.30)	3.15 (1.43)	1	-	8
8470	3470	Main + 11 Positions	Analog/9353	100	10.50 (266.70)	7.50 (190.50)	3.74 (1.70)	1	-	8
8076	3076	Main + 11 Positions	Analog/8246, 8244	100	10.50 (266.70)	7.50 (190.50)	4.24 (1.92)	1	-	8
8407	3407	Main + 11 Positions	Digital/8247	96	10.50 (266.70)	7.50 (190.50)	4.78 (2.17)	1	-	8
8485	3485	Main + 11 Positions	-	-	5.25 (133.35)	11.25 (285.75)	2.81 (1.27)	1	-	8
8464	3464	Main + 14 Positions	-	-	10.50 (266.70)	7.50 (190.50)	3.74 (1.70)	1	-	8
8471	3471	Main + 16 Positions	Analog/9630, 9353	100	14.75 (374.65)	7.50 (190.50)	5.96 (2.70)	1	-	13
8472	3472	Main + 19 Positions	Digital/8247	96	14.75 (374.65)	7.50 (190.50)	6.72 (3.05)	1	-	13
8465	3465	Main + 22 Positions	-	-	14.75 (374.65)	7.50 (190.50)	5.25 (2.38)	1	-	13
8486	3486	Main + 31 Positions	Analog/9630, 9353	100	14.75 (374.65)	11.25 (285.75)	8.94 (4.05)	1	-	22
8487	3487	Main + 34 Positions	Digital/8247	96	14.75 (374.65)	11.25 (285.75)	10.00 (4.54)	1	-	25

230 VOLT		AC Main Toggle Circuit Breaker Panels (Typical of Europe)								
PN	PN	Description	Meter/PN	Meter Page	Width in" (mm)	Height in" (mm)	Weight Lb (Kg)	Installed Double Pole Circuit Breakers		Installed Single Pole Circuit Breaker
								16A	32A	8A
8177	3177	Main only	-	-	2.63 (66.68)	3.75 (95.25)	0.51 (0.23)	1	-	-
8179	3179	Main only	-	-	2.63 (66.68)	3.75 (95.25)	0.51 (0.23)	-	1	-
8129	3129	Main + 1 Position	-	-	5.25 (133.35)	3.75 (95.25)	0.95 (0.43)	1	-	-
8143	3143	Main + 3 Positions	Analog/9354	100	5.25 (133.35)	7.50 (190.50)	2.00 (0.91)	1	-	3
8509	3509	Main + 3 Positions	Analog/8246, 8245	100	5.25 (133.35)	7.50 (190.50)	4.06 (1.84)	1	-	3
8505	3505	Main + 3 Positions	Digital/8247	96	5.25 (133.35)	7.50 (190.50)	2.94 (1.33)	1	-	3
8199	3199	Main + 4 Positions	-	-	10.50 (266.70)	3.75 (95.25)	2.22 (1.00)	1	-	4
8127	3127	Main + 6 Positions	-	-	5.25 (133.35)	7.50 (190.50)	1.87 (0.85)	1	-	3
8512	3512	Main + 6 Positions	-	-	10.50 (266.70)	4.50 (114.30)	1.90 (0.86)	1	-	4
8588	3588	Main + 8 Positions	Analog/9354	100	5.25 (133.35)	11.25 (285.75)	3.00 (1.36)	1	-	5
8174	3174	Main + 8 Positions	Analog/8246, 8245	100	5.25 (133.35)	11.25 (285.75)	3.18 (1.44)	1	-	5
8506	3506	Main + 8 Positions	Digital/8247	96	5.25 (133.35)	11.25 (285.75)	3.18 (1.44)	1	-	5
8563	3563	Main + 10 Positions	-	-	14.75 (374.65)	4.50 (114.30)	3.15 (1.43)	1	-	8
8570	3570	Main + 11 Positions	Analog/9354	100	10.50 (266.70)	7.50 (190.50)	3.74 (1.70)	1	-	8
8176	3176	Main + 11 Positions	Analog/8246, 8245	100	10.50 (266.70)	7.50 (190.50)	4.24 (1.92)	1	-	8
8507	3507	Main + 11 Positions	Digital/8247	96	10.50 (266.70)	7.50 (190.50)	4.78 (2.17)	1	-	8
8585	3585	Main + 11 Positions	-	-	5.25 (133.35)	11.25 (285.75)	2.81 (1.27)	1	-	8
8564	3564	Main + 14 Positions	-	-	10.50 (266.70)	7.50 (190.50)	3.74 (1.70)	1	-	8
8571	3571	Main + 16 Positions	Analog/9630, 9354	100	14.75 (374.65)	7.50 (190.50)	5.96 (2.70)	1	-	13
8572	3572	Main + 19 Positions	Digital/8247	96	14.75 (374.65)	7.50 (190.50)	6.72 (3.05)	1	-	13
8565	3565	Main + 22 Positions	-	-	14.75 (374.65)	7.50 (190.50)	5.25 (2.38)	1	-	13
8586	3586	Main + 31 Positions	Analog/9630, 9354	100	14.75 (374.65)	11.25 (285.75)	8.94 (4.05)	1	-	22
8587	3587	Main + 34 Positions	Digital/8247	96	14.75 (374.65)	11.25 (285.75)	10.00 (4.54)	1	-	25

AC BRANCH POWER DISTRIBUTION AND CIRCUIT PROTECTION

AC Branch Circuit Breaker Panels

▷ Available with white or black circuit breakers installed. 

Common Features

- All hot, neutral, and safety ground buses installed, fully pre-wired
- Includes set of 30 common AC labels (see page 90)
- Label backlighting pre-installed
- All LEDs installed
- Maximum panel amperage - 100 Amperes

36 Position



8484/8584*   3484/3584* 

33 Position¹



8483/8583*   3483/3583* 

21 Position



8482/8582*   3482/3582* 

18 Position¹



8481/8581*   3481/3581* 

24 Position



8265/8165*   3265/3165* 

12 Position



8460/8560*   3460/3560* 

13 Position



8479/8579*   3479/3579* 

16 Position



8461/8561*   3461/3561* 

8 Position



8411/8511*   3411/3511* 





6 Position



8097/8197*   3097/3197* 





10 Position



8478/8578*   3478/3578*  





13 Position



8480/8580*   3480/3580*  





8 Position



8059/8159*   3059/3159*  

3 Position



8058/8158*   3058/3158*  

AC BRANCH POWER DISTRIBUTION AND CIRCUIT PROTECTION

¹ Maximum panel amperage - 50 Amperes
*230 Volt (typical of Europe)

Use the tables below to select AC Distribution Panels with AC Branch Circuit Breakers where a single AC electrical source is brought to the panel and AC Main Circuit Protection has been provided elsewhere.

120 VOLT		AC Branch Toggle Circuit Breaker Panels							
PN	PN	Description	Meter Type/PN	Meter Page	Width in" (mm)	Height in" (mm)	Weight Lb (Kg)	Installed Single Pole Circuit Breakers	
								8A	15A
8058	3058	3 Position	-	-	5.25 (133.35)	3.75 (95.25)	1.14 (0.52)	-	3
8097	3097	6 Position	-	-	10.50 (266.70)	3.75 (95.25)	2.22 (1.00)	-	6
8059	3059	8 Position	-	-	5.25 (133.35)	7.50 (190.50)	1.85 (0.84)	-	5
8411	3411	8 Position	-	-	10.50 (266.70)	4.50 (114.30)	1.90 (0.86)	-	6
8478	3478	10 Position	Analog/9353	100	5.25 (133.35)	11.25 (285.75)	3.00 (1.36)	-	7
8460	3460	12 Position	-	-	14.75 (374.64)	4.50 (114.30)	3.15 (1.43)	-	10
8479	3479	13 Position	Analog/9353	100	10.50 (266.70)	7.50 (190.50)	3.74 (1.70)	-	10
8480	3480	13 Position	-	-	5.25 (133.35)	11.25 (285.75)	2.81 (1.27)	-	10
8461	3461	16 Position	-	-	10.50 (266.70)	7.50 (190.50)	3.74 (1.70)	-	10
8481	3481	18 Position	Analog/9630, 9353	100	14.75 (374.64)	7.50 (190.50)	5.96 (2.70)	-	15
8482	3482	21 Position	Digital/8247	96	14.75 (374.64)	7.50 (190.50)	6.72 (3.05)	-	15
8265	3265	24 Position	-	-	14.75 (374.64)	7.50 (190.50)	5.12 (3.32)	-	15
8483	3483	33 Position	Analog/9630, 9353	100	14.75 (374.64)	11.25 (285.75)	8.94 (4.05)	-	24
8484	3484	36 Position	Digital/8247	96	14.75 (374.64)	11.25 (285.75)	10.00 (4.54)	-	27

230 VOLT		AC Branch Toggle Circuit Breaker Panels (Typical of Europe)							
PN	PN	Description	Meter/PN	Meter Page	Width in" (mm)	Height in" (mm)	Weight Lb (Kg)	Installed Single Pole Circuit Breakers	
								8A	15A
8158	3158	3 Position	-	-	5.25 (133.35)	3.75 (95.25)	1.14 (0.52)	3	-
8197	3197	6 Position	-	-	10.50 (266.70)	3.75 (95.25)	2.22 (1.00)	6	-
8159	3159	8 Position	-	-	5.25 (133.35)	7.50 (190.50)	1.85 (0.84)	5	-
8511	3511	8 Position	-	-	10.50 (266.70)	4.50 (114.30)	1.90 (0.86)	6	-
8578	3578	10 Position	Analog/9354	100	5.25 (133.35)	11.25 (285.75)	3.00 (1.36)	7	-
8560	3560	12 Position	-	-	14.75 (374.64)	4.50 (114.30)	3.15 (1.43)	10	-
8579	3579	13 Position	Analog/9354	100	10.50 (266.70)	7.50 (190.50)	3.74 (1.70)	10	-
8580	3580	13 Position	-	-	5.25 (133.35)	11.25 (285.75)	2.81 (1.27)	10	-
8561	3561	16 Position	-	-	10.50 (266.70)	7.50 (190.50)	3.74 (1.70)	10	-
8581	3581	18 Position	Analog/9630, 9354	100	14.75 (374.64)	7.50 (190.50)	5.96 (2.70)	15	-
8582	3582	21 Position	Digital/8247	96	14.75 (374.64)	7.50 (190.50)	6.72 (3.05)	15	-
8165	3165	24 Position	-	-	14.75 (374.64)	7.50 (190.50)	5.12 (3.32)	15	-
8583	3583	33 Position	Analog/9630, 9354	100	14.75 (374.64)	11.25 (285.75)	8.94 (4.05)	24	-
8584	3584	36 Position	Digital/8247	96	14.75 (374.64)	11.25 (285.75)	10.00 (4.54)	27	-

Combination AC/DC Circuit Breaker Panels

Common Features

- Includes set of 30 common AC and 30 common DC labels (see page 90)
- All AC and DC buses installed, fully pre-wired
- Label backlighting pre-installed
- Red reverse polarity indicating LED
- All LEDs installed
- Maximum panel amperage - 100 Amperes DC/50 Amperes AC

▶ Available with white or black circuit breakers installed. 

AC Main + 6 Positions/DC 16 Position



8684/8685*

DC Features

- Owner upgradeable to 24 Volt DC with 8240, 18-32 Volt DC Voltmeter

AC Main + 6 Positions/DC Main + 18 Positions



8408/8508*  3408/3508* 

AC Features

- Ready for installation of optional 4029 AC Isolation Cover (see page 88)

DC Features

- 100 Ampere C-Series Circuit Breaker provides main circuit protection and switching for DC branch circuits
- All positive, negative and grounding buses installed fully prewired

AC Main + 8 Positions/DC Main + 29 Positions



8095/8195*  3095/3195* 

DC Features

- Owner upgradeable to 24 Volt DC with 8240, 18-32 Volt DC Voltmeter

AC 2 Sources + 12 Positions/DC Main + 19 Positions



8086/8186*  3086/3186* 

AC Features

- Ready for installation of optional 4031 AC Isolation Cover (see page 88)

DC Features

- 100 Ampere C-Series Circuit Breaker provides main circuit protection and switching for DC branch circuits
- All positive, negative and grounding buses installed fully prewired

AC Main + 6 Positions/DC Main + 15 Positions



8084/8184*  3084/3184* 

AC Features

- Ready for installation of optional 4029 AC Isolation Cover - 2 required (see page 88)

DC Features

- 100 Ampere C-Series Circuit Breaker provides main circuit protection and switching for DC branch circuits
- Owner upgradeable to 24 Volt DC with 8240, 18-32 Volt DC Voltmeter

AC 2 Sources + 12 Positions/DC Main + 7 Positions



8085/8185*  3085/3185* 

AC Features

- Ready for installation of optional 4029 AC Isolation Cover - 2 required (see page 88)

DC Features

- 100 Ampere C-Series Circuit Breaker provides main circuit protection and switching for DC branch circuits
- Owner upgradeable to 24 Volts DC with 8240, 18-32 Volt DC Voltmeter

* 230 Volt (typical of Europe)

Blue Sea Systems

Specifications subject to change. See www.blueseasystems.com for current information.

120 VOLT		AC/DC Toggle Circuit Breaker Panels										
PN	PN	Description	Voltage	Meter Type/PN	Width in" (mm)	Height in" (mm)	Weight Lb (Kg)	Installed AC Circuit Breakers			Installed DC Circuit Breakers	
								30A	50A	15A	100A Main	15A
8085	3085	AC 2 Sources + 12 Positions DC Main + 7 Positions	120V AC 12V DC	Analog*/8003, 9630, 9353	14.75 (374.65)	10.00 (254.00)	6.50 (2.95)	2	-	9	1	4
8084	3084	AC Main + 6 Positions DC Main + 15 Positions	120V AC 12V DC	Analog*/8003, 8017, 9353	14.75 (374.65)	10.00 (254.00)	6.50 (2.95)	1	-	3	1	9
8408	3408	AC Main + 6 Positions DC Main + 18 positions	120V AC 12/24V DC	Digital**/8247, 8248	15.75 (400.05)	10.00 (254.00)	8.73 (3.96)	1	-	3	1	12
8086	3086	AC 2 Sources + 12 Positions DC Main + 19 Positions	120V AC 12V DC	Analog*/8003, 8017, 9630, 9353	19.50 (495.30)	11.50 (292.10)	12.80 (5.81)	3	1	6	1	13
8095	3095	AC Main + 8 Positions DC Main + 29 Positions	120V AC 12V DC	Analog*/8003, 8017, 9630, 9353	19.50 (495.30)	11.50 (292.10)	12.80 (5.81)	1	-	5	1	20

230 VOLT		AC/DC Toggle Circuit Breaker Panels (Typical of Europe)										
PN	PN	Description	Voltage	Meter Type/PN	Width in" (mm)	Height in" (mm)	Weight Lb (Kg)	Installed AC Circuit Breakers			Installed DC Circuit Breakers	
								16A	32A	8A	100A Main	15A
8185	3185	AC 2 Sources + 12 Positions DC Main + 7 Positions	230V AC 12V DC	Analog*/8003, 9630, 9354	14.75 (374.65)	10.00 (254.00)	6.50 (2.95)	2	-	9	1	4
8184	3184	AC Main + 6 Positions DC Main + 15 Positions	230V AC 12V DC	Analog*/8003, 8017, 9354	14.75 (374.65)	10.00 (254.00)	6.50 (2.95)	1	-	3	1	9
8508	3508	AC Main + 6 Positions DC Main + 18 positions	230V AC 12/24V DC	Digital**/8247, 8248	15.75 (400.05)	10.00 (254.00)	8.73 (3.96)	1	-	3	1	12
8186	3186	AC 2 Sources + 12 Positions DC Main + 19 Positions	230V AC 12V DC	Analog*/8003, 8017, 9630, 9354	19.50 (495.30)	11.50 (292.10)	12.80 (5.81)	3	1	6	1	13
8195	3195	AC Main + 8 Positions DC Main + 29 Positions	230V AC 12V DC	Analog*/8003, 8017, 9630, 9354	19.50 (495.30)	11.50 (292.10)	12.80 (5.81)	1	-	5	1	20

120 VOLT		AC/DC Rocker Circuit Breaker Panels										
PN	Description	Voltage	Meter Type/PN	Width in" (mm)	Height in" (mm)	Weight Lb (Kg)	Installed AC Circuit Breakers				Installed DC Circuit Breakers	
							16A	30A	8A	15A	100A Main	15A
8684	AC Main + 6 Positions DC 16 Positions	120V AC 12V DC	Analog*/8003, 8017, 9353	14.75 (374.65)	10.00 (254.00)	6.50 (2.95)	-	1	-	3	-	10

230 VOLT		AC/DC Rocker Circuit Breaker Panels (Typical of Europe)										
PN	Description	Voltage	Meter Type/PN	Width in" (mm)	Height in" (mm)	Weight Lb (Kg)	Installed AC Circuit Breakers				Installed DC Circuit Breakers	
							16A	30A	8A	15A	100A Main	15A
8685	AC Main + 6 Positions DC 16 Position	230V AC 12V DC	Analog*/8003, 8017, 9354	14.75 (374.65)	10.00 (254.00)	6.50 (2.95)	1	-	3	-	-	10

* Analog meters see pages 100-102
 ** Digital meters see pages 95-99, 102

Combined AC/DC panels require a Circuit Breaker Isolating Cover to meet ABYC Standards.

ABYC E11.11.1.1. In the case of systems with a combined AC and DC panel, the panel shall be designed so that when the panel is open there is no access to energized AC parts without the use of tools.



PN 4031 Circuit Breaker Isolating Cover (see page 88) Installed on PN 8086 AC/DC Circuit Breaker Panel (see page 84)

Panel Switches

- Perfect for generator starters, bilge pumps, horns, wipers, engine controls and any other application that requires switching action other than ON-OFF or different pole configuration separate from circuit protection
- All panel switches mount in Blue Sea Systems toggle type circuit breaker panels
- Supplied with mounting adapter for standard 5/8" circuit breaker mounting hole
- Nickel-plated brass and phenolic non-corrosive construction

Specifications	Toggle Switches	Push Button Switch
Rating 250 Volts AC	10 Amperes	3 Amperes
Rating 125 Volts AC	15 Amperes	6 Amperes
Rating 32 Volts DC	15 Amperes	6 Amperes
Terminal Size	0.25" (6.35mm)	0.25" (6.35mm)
Terminal Type	Quick Connect Tab	Quick Connect Tab
Actuator Color	White	White

PN	Type	Pole/Throw	Action	Weight Lb (Kg)
8200	Push Button	SPST	OFF-(ON)	0.07 (0.03)
8204	Toggle	SPST	OFF-ON	0.08 (0.04)
8205	Toggle	SPST	OFF-(ON)	0.08 (0.04)
8206	Toggle	SPDT	ON-OFF-ON	0.08 (0.04)
8207	Toggle	SPDT	(ON)-OFF-ON	0.08 (0.04)
8208	Toggle	SPDT	(ON)-OFF-(ON)	0.08 (0.04)
8209	Toggle	DPST*	OFF-ON-(ON) OFF-OFF-(ON)	0.08 (0.04)
8210	Toggle	DPST	OFF-ON	0.08 (0.04)
8211	Toggle	DPDT	ON-OFF-ON	0.08 (0.04)
8212	Toggle	DPDT	(ON)-OFF-ON	0.08 (0.04)

() = momentary

*Progressive Two Circuit Switch - maintains circuit one while momentarily switching circuit two

Push Button Switch



8200

Toggle Switch



8204-8212

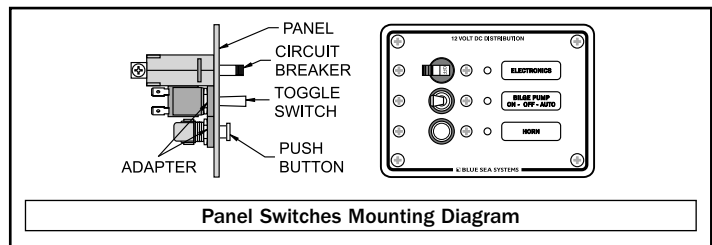
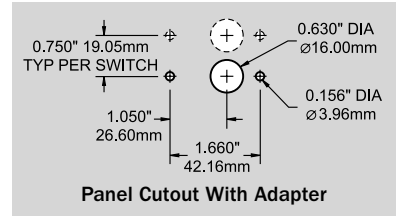
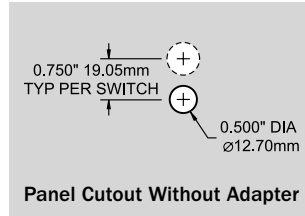

Circuit Breaker Mounting Screws

- Fits all single and double pole Toggle Type, Rocker and C-Series circuit breakers
- Sold in packages of 6

PN	Description	Weight Lb (Kg)
8035	6-32 x 1/4" Flat Head	0.03 (0.01)



8035

Circuit Breaker Panel Plug

- Black plug fits standard toggle World Circuit Breaker hole

PN	Description	Weight Lb (Kg)
8037	Circuit Breaker Panel Plug	0.03 (0.01)



8037

Rocker Series CLB Adapter

- Fits on Blue Sea Systems Rocker Panels and new Battery Management Panels (see pages 20-21, 45, 76)

PN	Description	Weight Lb (Kg)
4111	Circuit Breaker Panel Adapter	0.03 (0.01)

NEW PRODUCT



4111

24 Hour Round Label

- Tough, weatherproof material
- Fits over any Blue Sea Systems LED
- Sold in packages of 12
- Used on any standard panel
- Included with Battery Management Panels (see pages 20-21)

PN	Description
4140	24 Hour Round Label

NEW PRODUCT

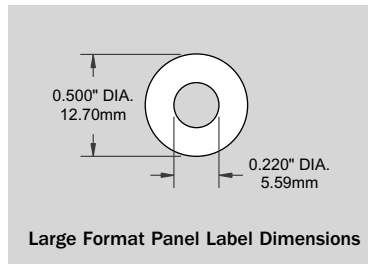

Large Format Panel Label Dimensions



4140



5021

Water Resistant Fuse Holder

- Improved, easy to open, water resistant fuse holder
- Withstands water exposure normally encountered in above deck applications: rain, sea spray or hose spray washdown

Specifications

Mounting Hole Size 0.506" (12.8mm)

PN	Description	Weight Lb (Kg)
5021	Water Resistant Fuse Holder	0.02 (0.01)

LED Indicator Lights

- Easily installed in any Blue Sea Systems circuit breaker panel
- Simple push-in installation mounts in any thickness material
- Useful as general indicator and alarm lights



Specifications

Mounting Hole Size 11/64" (4.36mm)

CE marked

PN	Color	Voltage	Amperage Draw	Weight Lb (Kg)
8033	Amber	12/24V DC	5 Milliampers	0.07 (0.03)
8171	Red	12/24V DC	5 Milliampers	0.07 (0.03)
8172	Green	12/24V DC	5 Milliampers	0.07 (0.03)
8169	Amber	120V AC	0.5 Milliampers	0.07 (0.03)
8066	Red	120V AC	0.5 Milliampers	0.07 (0.03)
8034	Green	120V AC	0.5 Milliampers	0.07 (0.03)
8167	Amber	230V AC	0.25 Milliampers	0.07 (0.03)
8166	Red	230V AC	0.25 Milliampers	0.07 (0.03)
8134	Green	230V AC	0.25 Milliampers	0.07 (0.03)



8072

8173

Mounting Panel for Toggle Type Magnetic Circuit Breakers

- Mounts any World or A-Series single or double pole circuit breaker or panel switch
- Slate gray matches standard panel color

Specifications

Panel Material 0.125" Aluminum 5052 Alloy

Dimensions 2.63" (66.68mm) x 3.75" (95.25mm)

PN	Description	Weight Lb (Kg)
8072	Mounting Panel - Single Pole	0.08 (0.04)
8173	Mounting Panel - Double Pole	0.08 (0.04)

▶ See page 54 for single and double pole World Circuit Breakers

RATED 12 or 24 VOLT DC

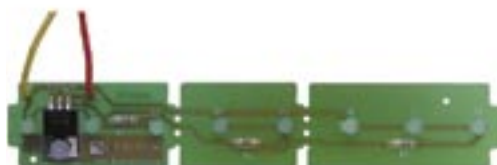

8065

Label Backlight System

- Easily installed in Blue Sea Systems circuit breaker panels
- Connects to 12 or 24 Volt sources via two 6" 18 AWG wire leads
- Backlighting is standard on panels - No kit required
- Reverse polarity protection built-in
- PN 8065 snaps apart for 5 or 3 positions

Specifications

Voltage 12 or 24 Volts DC

Amperage Draw <7 mA per label

PN	Description	Weight Lb (Kg)
8065	8/5/3 Positions	0.07 (0.03)
8384	4 Positions	0.05 (0.02)
8069	10 Positions	0.09 (0.04)
8383	13 Positions	0.11 (0.05)

Toggle Guard

- Protects circuit breakers from being accidentally switched ON or OFF
- Fits all World or A-Series single pole toggle circuit breakers
- Fits all panel switches (see page 86_)
- Can be used on any brand of circuit breaker panel using standard toggle type circuit breakers
- Uses circuit breaker mounting screw hole
- Includes 2 mounting screws

Specifications

Material Acetal
 Mounting Hole Size #6 Flat Head Screw

PN	Description	Weight Lb (Kg)
4100	Toggle Guard	0.05 (0.02)



4100 (2 shown)

World and Rocker AC Lockout Slide

- Allows only 1 double pole AC circuit breaker to be activated at a time
- Guarantees that AC power from 2 or 3 sources (shore power, genset, or inverter) will not be mixed
- Fits all double pole World or A-Series and Rocker Circuit Breaker Panels (see page 63, 72)
- Uses circuit breaker mounting screw holes - Requires no modification
- Includes mounting screws

Specifications

Material Acetal
 Mounting Screw Size #6 Flat Head Screw

PN	Poles	AC Sources	Weight Lb (Kg)
4125	2	2	0.06 (0.03)
4126	2	3	0.07 (0.03)



4125



4126

AC C-Series Circuit Breaker Lockout Slide

- Allows only 1 of a pair of double pole or triple pole AC circuit breakers to be activated at a time
- Guarantees that AC power from 2 sources (shore power, genset, or inverter) will not be mixed
- Fits all double pole or triple pole C-Series Circuit Breakers shown (see page 65, 74)
- Uses circuit breaker mounting screw holes
- Requires no special panel modification
- Includes mounting screws

Specifications

Material Acetal
 Mounting Screw Size #6 Flat Head Screw

PN	Poles	Positions	Weight Lb (Kg)
4130	2	2	0.06 (0.03)
4131	3	2	0.17 (0.08)



4130



4131

Circuit Breaker Insulating Covers

- Provides electrical insulation for exposed panel backs
- Provides mechanical protection for panel backs protruding into lockers
- Lightweight material is easily drilled for wire entrance and exit
- AC isolation covers meet ABYC safety requirements for panels with combined AC and DC loads

Specifications

Material ABS

PN	Description	Weight Lb (Kg)
4026	Cover for 5-1/4" x 3-3/4"	0.09 (0.04)
4027	Cover for 5-1/4" x 7-1/2"	0.14 (0.06)
4028	Cover for 10-1/2" x 7-1/2"	0.39 (0.18)
4029	Cover for 1 Column x 8 Position + Meter	0.24 (0.11)
4031	Cover for 2 Column x 10 Position + Meter	0.38 (0.17)



4031



4027



4031 installed on 8086 AC/DC Circuit Breaker Panel (see pages 84-85)

Blue Sea Systems Label Formats



WeatherDeck™ Water Resistant Panel Labels
- used on WeatherDeck™ Water Resistant Panels and new DC Battery Management Panels.

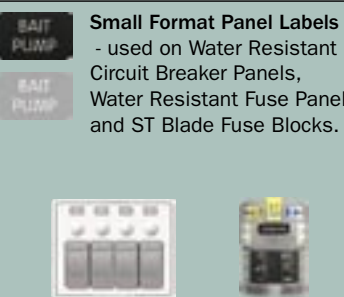

Small Format Panel Labels
- used on Water Resistant Circuit Breaker Panels, Water Resistant Fuse Panels, and ST Blade Fuse Blocks.

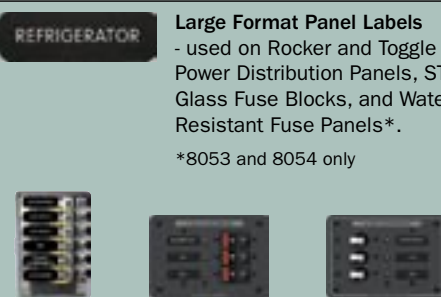

Large Format Panel Labels
- used on Rocker and Toggle Power Distribution Panels, ST Glass Fuse Blocks, and Water Resistant Fuse Panels*.
*8053 and 8054 only

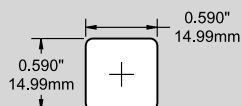

WeatherDeck™ Panel Label Dimensions

WeatherDeck™ Water Resistant Panel Labels

- Tough, weatherproof material
- Used on WeatherDeck™ Water Resistant Panels (see page 48-51)
- 4215 included with WeatherDeck™ Water Resistant Panels (see pages 48-51)
- 4218 included with DC Management Panels - 8686, 8687, 8689, 8690, 8691, and 8693 (see pages 20-21)

PN	Color	Description	Quantity	PN	Color	Description	Quantity
4215	Black	DC Labels	30 Labels	4216	Black	DC Labels	60 Labels
4218	Black	DC Labels	30 Labels	4217	Black	DC Labels	120 Labels

NEW PRODUCT

► See pages 48-51 for Blue Sea Systems WeatherDeck™ Panels

Order labels online at www.bluesea.com.

4215 Label Kit

- ACCESSORY
- AERATOR
- ANCHOR LIGHT
- AUTOPILOT
- BAIT PUMP
- BILGE PUMP
- BLOWER
- CABIN LIGHTS
- DEPTH SOUNDER
- ELECTRONICS
- GPS
- HORN
- INSTRUMENTS
- KNOTMETER
- NAVIGATION LIGHTS
- RADAR
- REFRIGERATOR
- RUNNING LIGHTS
- SEARCHLIGHT
- SPARE
- SPREADER LIGHTS
- STEAMING LIGHT
- STEREO
- TRIM TABS
- VHF
- WASHDOWN
- WATER PRESSURE
- WATER PUMP
- WINDLASS
- WIPERS

4218 Label Kit

- 12 V DC
- 24 V DC
- ALARM
- BILGE PUMP
- BILGE PUMP 2
- BILGE PUMP 3
- BILGE PUMP 4
- BOW THRUSTER
- CLOCK
- DC MAIN
- DC SUB PANEL
- ELECTRONICS
- ENGINE
- ENGINES
- ENG 1/ENG 2
- GENERATOR
- HOUSE
- HOUSE/ENG
- HOUSE/GEN
- INVERTER
- LIGHTS
- MEMORY
- PORT/STBD ENG
- RADAR
- RADIO
- SOLAR PANEL
- VHF
- WINCH
- WINDLASS
- BLANK (WRITE-ON)

4216 Label Kit

- (BLANK)
- 12 VOLT DC
- 12 VOLT DC OUTLETS
- ANCHOR WASH DOWN
- BAITWELL
- BATTERY
- BATTERY PARALLEL
- BILGE
- BILGE PUMP 2
- BILGE PUMP ON-OFF-AUTO
- BOW LIGHT
- CABIN
- CB RADIO
- CELLULAR PHONE
- CHART LIGHT
- CHART PLOTTER
- COCKPIT LIGHTS
- COMPASS LIGHT
- COURTESY LIGHTS
- DAVIT
- DC OUTLETS
- DC SUB PANEL
- DECK LIGHTS
- DOCKING LIGHTS
- DOWN RIGGER
- ELECTRIC HATCH
- ENGINE ROOM BLOWER
- ENGINE ROOM LIGHTS
- FAN
- FISH FINDER
- FISHING LIGHT
- FISHWELL PUMP
- FLOOD LIGHTS
- FRESH WATER PUMP
- FUEL PUMP
- GALLEY OUTLETS
- GAS ALARM
- GPS/PLOTTER
- HEAD
- IGNITION
- INSTRUMENT LIGHTS
- LIGHTS
- LIVWELL
- MACERATOR PUMP
- NAV LIGHT ANCHOR OFF NAV
- OUTLETS
- PUMPOUT
- RADIO
- SEAWATER WASH DOWN
- SHOWER SUMP PUMP
- SSB
- STERN LIGHT
- STROBE LIGHT
- TRICOLOR LIGHT
- TROLLING MOTOR
- WASHDOWN
- WATER MAKER
- WINCHES
- WIPER PORT
- WIPER STBD

4217 Label Kit

- (BLANK)
- 12 VOLT DC
- 12 VOLT DC OUTLETS
- 24V DC
- AIR HORN
- ANCHOR LIGHT MAIN
- ANCHOR LIGHT MIZZEN
- ANCHOR WASH DOWN
- APPLIANCES
- ARCH LIGHTS
- AUTO/MAN
- BAITWELL
- BATTERY
- BATTERY PARALLEL
- BILGE ALARM
- BILGE PUMP 2
- BILGE PUMP ON-OFF-AUTO
- BOW LIGHT
- BOW THRUSTER
- BRIDGE INSTRUMENTS
- BRIDGE LIGHTS
- CABIN
- CB RADIO
- CD PLAYER
- CHART LIGHT
- CHART PLOTTER
- COCKPIT LIGHTS
- COMPASS LIGHT
- COURTESY LIGHTS
- DAVIT
- DC OUTLETS
- DC SUB PANEL
- DECK LIGHTS
- DEFROSTER
- DEPTH/SPEED
- DIMMER
- DISCHARGE PUMP
- DOCKING LIGHT PORT
- DOCKING LIGHT STBD
- DOCKING LIGHTS
- DOWN RIGGER
- ELECTRIC HATCH
- ENGINE HATCH
- ENGINE INSTRUMENTS
- ENGINE ROOM BLOWER
- ENGINE ROOM LIGHTS
- ENGINE SHUTDOWN
- ENTRY STEP
- FAN
- FAN 2
- FIRE ALARM
- FIRE EXT
- FISH FINDER
- FISHING LIGHT
- FISHWELL PUMP
- FLOOD LIGHTS
- FLYBRIDGE
- FLYBRIDGE ELECTRONICS
- FLYBRIDGE LIGHTS
- FOG LIGHTS
- FOREDECK LIGHT
- FRESH WATER PUMP
- FRESH WATER WASH DOWN
- FUEL PUMP
- FUEL TRANSFER
- FURLER JIB
- FURLER MAINSAIL
- GALLEY
- GAS ALARM
- GPS/PLOTTER
- HAILER
- HAM RADIO
- HEAD
- HEATER
- IGNITION
- INSTRUMENT LIGHTS
- INTERCOM HAILER
- LAZARETTE LIGHTS
- LIGHTS
- LIGHTER
- LIVWELL
- LOCKER LIGHTS
- LPG CONTROL
- MAIN
- MAST LIGHTS
- MASTHEAD LIGHT
- MIZZEN FLOOD
- NAVIGATION ELECTRONICS
- NAVIGATION INSTRUMENTS
- NAV LIGHT ANCHOR OFF NAV
- ON-OFF
- OUTLETS
- PUMP
- PUMPOUT
- RADIO
- ROD LOCKER
- RUDDER ANGLE INDICATOR
- SAILING CONTROLS
- SAILING INSTRUMENTS
- SALT WATER PUMP
- SEAWATER WASH DOWN
- SHOWER SUMP PUMP
- SOLAR PANEL
- SSB
- START-STOP
- STERN LIGHT
- STROBE LIGHT
- SUMP PUMP
- TRANSFER
- TRICOLOR LIGHT
- TROLLING MOTOR
- WASHDOWN PUMP
- WASHDOWN
- WINCHES
- WIND GENERATOR
- WIND INSTRUMENTS
- WINDSHIELD WASHER
- WIPER CENTER
- WIPER PORT
- WIPER STBD

Small Format Panel Labels

- Tough, weatherproof material
- 8214 and 8217 - Includes 60 common DC labels
- 8214 and 8217 - Used on DC Water Resistant Panels (pages 52-53) and ST Blade Fuse Blocks (see page 57)
- 4139 - Write-on circuit labels used on ST Blade Fuse Blocks (see page 57)

PN	Color	Description	Quantity
8214	Black	Small Format Panel Labels	60 Labels
8217	Gray	Small Format Panel Labels	60 Labels

- ▶ See page 57 for Blue Sea Systems ST Blade Fuse Blocks.
- ▶ See pages 52, 53 for Blue Sea Systems Water Resistant Circuit Breaker Panels and Water Resistant Fuse Panels (8261 and 8262).

DC Small Format Label Listing			
(BLANK)	CABIN	GAS ALARM	SEARCH LIGHT
12 VOLT DC	CABIN LIGHTS	GPS	SPARE
24 VOLT DC	CB RADIO	HORN	SPREADER LIGHTS
ACCESSORY	CELLULAR PHONE	IGNITION	STEAMING LIGHT
AERATOR	CHARGER INVERTER	INSTR. LIGHTS	STEREO
ANCHOR LIGHT	CHART PLOTTER	INVERTER	STROBE LIGHT
AUTO PILOT	DECK LIGHTS	KNOT METER	TRICOLOR LIGHT
BAIT PUMP	DEPTH SOUNDER	LIGHTS	TRIM TABS
BAITWELL	DOWN RIGGER	LIVEWELL	VHF
BATTERY	ELECTRONICS	NAV LIGHTS	WASH DOWN
BATTERY CHARGER	FAN	OUTLETS	WATER PRESSURE
BILGE	FISH FINDER	RADIO	WATER PUMP
BILGE PUMP	FISHING LIGHT	RADAR	WINCHES
BLOWER	FLOOD LIGHTS	REFRIGERATOR	WINDLASS
BOW LIGHT	FUEL PUMP	RUNNING LIGHTS	WIPERS

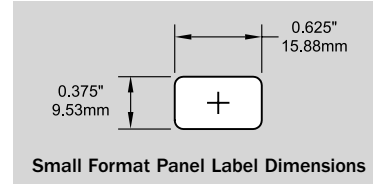

Order labels online at www.bluesea.com.

Large Format Panel Labels

For use with Blue Sea Systems Rocker and Toggle Power Distribution Panels, ST Glass Fuse Blocks, and Water Resistant Fuse Panels (8053 and 8054).

- Tough, weatherproof material
- Used on water resistant panels
- Large Format Panel Labels are available for purchase individually or in sets. Individual labels and label sets are listed on pages 91-94. To purchase individual Large Format Panel Labels online go to www.bluesea.com.

PN	Color	Description	Quantity
8031	Black	AC Panel Basic	30 Labels
8067	Black	AC Panel Extended	120 Labels
8030	Black	DC Panel Basic	30 Labels
8039	Black	DC Panel Extended	120 Labels

- ▶ See pages 90-94 for label listing and part numbers.

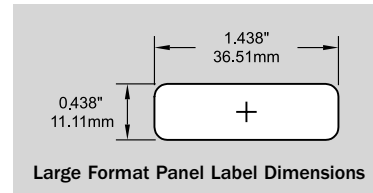

Order labels online at www.bluesea.com.

REFRIGERATOR

Label Number	Description	8067 AC Extended				Label Number	Description	8067 AC Extended			
		8031 AC Basic		8039 DC Extended	8030 DC Basic			8031 AC Basic		8039 DC Extended	8030 DC Basic
		8039 DC Basic	8030 DC Basic					8039 DC Basic	8030 DC Basic		
1	#1				485	BEDROOM SLIDEOUT					
2	#2				55	BILGE					
3	(BLANK)			✓	56	BILGE ALARM				✓	
5	12 VOLT DC			✓	57	BILGE ALARM 2					
4	12 VOLT DC OUTLETS			✓	58	BILGE ALARM 3					
499	12 VOLT OUTLETS INSIDE				59	BILGE ALARM 4					
500	12 VOLT OUTLETS OUTSIDE				60	BILGE LIGHTS					
502	120 VOLT 60Hz SHORE POWER				61	BILGE PUMP			✓		
6	120 VOLT AC OUTLETS				62	BILGE PUMP 2				✓	
7	120 VOLT AC / 60 HZ				63	BILGE PUMP 3					
516	120/240V 60Hz				64	BILGE PUMP 4					
517	120/240V 60Hz SHORE POWER				453	BILGE PUMP ON-OFF-AUTO					
10	24 VOLTS DC				65	BLOWER			✓		
9	24 VOLT DC OUTLET				66	BOAT DAVIT					
8	240 VOLTS AC				67	BOOM LIGHT					
460	240 VOLTS AC / 60 HZ				68	BOW LIGHT					
515	250 VOLT 50Hz SHORE POWER				69	BOW THRUSTER					
468	250 VOLTS AC / 50 HZ				70	BRIDGE					
462	AC BUS 1				71	BRIDGE INSTRUMENTS				✓	
11	AC COMPRESSOR				72	BRIDGE LIGHTS					✓
12	AC FAN				73	BRIDGE OUTLETS					✓
13	AC MAIN				74	CABIN					✓
14	AC PANEL				75	CABIN 2					✓
15	AC POWER				501	CABIN 2 FAN					
16	AC REFRIGERATOR				76	CABIN 2 LIGHTS			✓		✓
17	AC SUB PANEL				77	CABIN 2 OUTLETS					✓
18	ACCESSORY	✓		✓	78	CABIN 3					✓
19	ADF				79	CABIN 3 LIGHTS			✓		✓
20	AERATOR				80	CABIN 3 OUTLETS					✓
21	AFT CABIN			✓	81	CABIN 4					✓
22	AFT CABIN LIGHTS			✓	82	CABIN 4 LIGHTS			✓		✓
23	AFT CABIN OUTLETS			✓	83	CABIN 4 OUTLETS					✓
24	AFT HEAD			✓	84	CABIN FAN			✓		
25	AIR COMPRESSOR				85	CABIN HEATER					✓
26	AIR CONDITIONER			✓	86	CABIN LIGHTS			✓		✓
27	AIR CONDITIONER 2			✓	87	CABIN OUTLETS				✓	
28	AIR CONDITIONER 3				88	CABLEMASTER					
29	AIR CONDITIONER 4				89	CASSETTE PLAYER					
30	AIR CONDITIONER PUMP				90	CB RADIO			✓		
31	AIR HORN				91	CCTV					✓
32	ALARM SYSTEM			✓	92	CD PLAYER					
461	ALTERNATOR			✓	93	CELLULAR PHONE			✓		
33	ALTERNATOR DISCONNECT				94	CHARGER/INVERTER					✓
34	AMPLIFIER				95	CHART LIGHT			✓		
35	ANCHOR LIGHT	✓			96	CHART PLOTTER			✓		
36	ANCHOR LIGHT MAIN				97	CHOKE					
37	ANCHOR LIGHT MIZZEN				98	CIRCULATOR PUMP					
38	ANCHOR WASH DOWN			✓	508	CLOCK					
39	APPLIANCES			✓	99	CLOSET LIGHT					
40	ARCH LIGHTS				100	COCKPIT LIGHTS			✓		✓
41	AUDIO/VIDEO SYSTEM				101	COCKPIT REFRIG					✓
42	AUTO/MAN				102	COLOR SOUNDER			✓		
524	AUTOMATIC CHARGING RELAY				103	COMM ELECTRONICS			✓		
43	AUTOPILOT	✓			104	COMPARTMENT HEATER					
44	BAIT PUMP			✓	105	COMPARTMENT LIGHT					✓
45	BAITWELL				106	COMPASS LIGHT			✓		
46	BALLAST CONTROLS				107	COMPUTER				✓	
47	BALLAST PUMP				514	COMPUTER DISPLAY					
48	BAR				108	CONDENSER PUMP					
481	BATHROOM				109	CONSOLE LIGHT					
49	BATTERY				110	CONVERTER					
473	BATTERY 1				111	COOKING GRILL					
474	BATTERY 2				112	COOKTOP					✓
50	BATTERY CHARGER			✓	113	COOLING PUMP					
51	BATTERY CHARGER 2			✓	114	COURTESY LIGHTS					
52	BATTERY COMPARTMENT				115	CREW LIGHTS					
53	BATTERY PARALLEL				116	CREW QUARTERS					
54	BEACON				117	DAVIT					
480	BEDROOM				118	DC LIGHTS			✓		

PANEL ACCESSORIES

LARGE FORMAT PANEL LABELS LISTING

REFRIGERATOR

Label Number	Description	8067 AC Extended			Label Number	Description	8067 AC Extended		
		8031 AC Basic		8039 DC Extended			8031 AC Basic		8039 DC Extended
		8030 DC Basic					8030 DC Basic		
119	DC MAIN		✓		187	FIRE HORN			
120	DC OUTLETS		✓		459	FISH FINDER			
121	DC REFRIGERATOR		✓		188	FISHBOX ICEMAKER			
122	DC SUB PANEL		✓		520	FISHBOX PUMP			
123	DECK				521	FISHBOX REFRIGERATOR			
124	DECK LIGHTS		✓	✓	189	FISHING LIGHT		✓	
125	DECK LIGHTS AFT		✓		487	FISHWELL PUMP			
126	DECK LIGHTS FWD		✓		488	FISHWELL PUMP 2			
127	DECK LIGHTS PORT				190	FLOOD LIGHTS		✓	✓
128	DECK LIGHTS STBD				191	FLOSCAN			
129	DEFROSTER				192	FLYBRIDGE			
130	DEPTH RECORDER		✓		193	FLYBRIDGE ELECTRONICS		✓	
131	DEPTH SOUNDER	✓			194	FLYBRIDGE LIGHTS		✓	
132	DEPTH/SPEED		✓		195	FLYBRIDGE OUTLETS			
133	DESALINATOR		✓		196	FOG LIGHTS			
134	DIMMER		✓	✓	197	FOREDECK LIGHT	✓		
135	DINING AREA LIGHTS		✓	✓	198	FREEZER			✓
136	DINING AREA OUTLETS			✓	199	FRESH WATER			
137	DISCHARGE PUMP				200	FRESH WATER PUMP		✓	
138	DISHWASHER			✓	201	FRESH WATER PUMP 2			
139	DISPOSAL			✓	202	FRESH WATER PUMP 3			
140	DIVE COMPRESSOR				203	FRESH WATER PUMP 4			
141	DOCKING LIGHT PORT				204	FRESH WATER WASH DOWN		✓	
142	DOCKING LIGHT STBD				482	FRONT SLIDEOUT			
143	DOCKING LIGHTS		✓		205	FUEL PRIMER PUMP			
144	DOWN RIGGER				206	FUEL PUMP			
145	DRYER			✓	207	FUEL PUMP 2			
146	DUMP VALVES				208	FUEL PUMP 3			
147	ELECTRIC HATCH				209	FUEL PUMP 4			
469	ELECTRONIC CONTROL UNIT				210	FUEL TANK HEATER			
148	ELECTRONICS	✓			211	FUEL TRANSFER			
149	EMERGENCY BACKUP SYS				507	FUME DETECTOR			
150	EMERGENCY LIGHTS		✓	✓	212	FURLER JIB			
151	EMERGENCY PUMPS				213	FURLER MAINSAIL			
158	ENGINE ALARM		✓		214	FURLER SPINNAKER			
159	ENGINE BLOCK HEATER				215	FURNACE			✓
160	ENGINE CONTROL PORT				216	FWD CABIN			
161	ENGINE CONTROL STBD				217	FWD CABIN LIGHTS	✓		✓
162	ENGINE CONTROLS				218	FWD CABIN OUTLETS			✓
163	ENGINE DRIVEN REFRIG				219	GALLEY			✓
164	ENGINE EXHAUST FAN				220	GALLEY APPLIANCES			✓
165	ENGINE HATCH				221	GALLEY DRAIN			
166	ENGINE HEATER PORT				222	GALLEY FAN			
167	ENGINE HEATER STBD				223	GALLEY LIGHTS		✓	✓
168	ENGINE INSTRUMENTS	✓			224	GALLEY OUTLETS		✓	
169	ENGINE OIL PAN PUMP				490	GALVANIC ISOLATOR			
152	ENGINE ROOM BILGE ALARM		✓		225	GARBAGE DISPOSAL			✓
153	ENGINE ROOM BLOWER				226	GAS ALARM			
154	ENGINE ROOM HEATER				227	GENERAL PURPOSE			
155	ENGINE ROOM LIGHTS		✓	✓	523	GENERATOR			
156	ENGINE ROOM OUTLETS			✓	228	GENERATOR 1			✓
157	ENGINE ROOM PANEL MAIN		✓		229	GENERATOR 2			
170	ENGINE SHUTDOWN				454	GENERATOR OFF ON START			
171	ENGINE TEMP				230	GENERATOR ROOM BLOWER			
172	ENTERTAINMENT CENTER			✓	466	GENERATOR RUNNING			
173	ENTRANCE DOOR				455	GENERATOR STOP			
174	ENTRY STEP				231	GFI OUTLET			✓
175	EXHAUST FAN			✓	232	GPS	✓		
176	EXHAUST TEMP				233	GPS/LORAN			
177	EXTERIOR				234	GPS/PLOTTER		✓	
178	EXTERIOR LIGHTS		✓	✓	510	GUN LOCKS			
179	FAN	✓		✓	235	GYRO COMPASS			
180	FAN 2		✓	✓	236	HAILER		✓	
181	FAN 3			✓	237	HALLWAY LIGHTS			✓
182	FAN 4			✓	238	HALON FIRE SYSTEM			
183	FAX				239	HAM RADIO		✓	
184	FILLING PUMP				240	HEAD		✓	
185	FIRE ALARM		✓		241	HEAD 2			
186	FIRE EXT				242	HEAD 2 FAN			

REFRIGERATOR					8067 AC Extended					8067 AC Extended							
					8031 AC Basic					8031 AC Basic							
Label Number	Description	8039 DC Extended			✓	Label Number	Description	8039 DC Extended			✓	Label Number	Description	8039 DC Extended			
		8030 DC Basic						8030 DC Basic						8030 DC Basic			
243	HEAD 2 OUTLETS				✓	299	LIGHTS STBD					299	LIGHTS STBD				
244	HEAD 3					300	LIVWELL				✓	300	LIVWELL				✓
245	HEAD 3 FAN					301	LIVWELL INPUT					301	LIVWELL INPUT				
246	HEAD 3 OUTLETS				✓	302	LIVWELL OUTPUT					302	LIVWELL OUTPUT				
247	HEAD 4					303	LOCKER LIGHTS					303	LOCKER LIGHTS				
248	HEAD 4 FAN					304	LOG				✓	304	LOG				✓
249	HEAD 4 OUTLETS				✓	305	LORAN				✓	305	LORAN				✓
250	HEAD FAN					306	LPG CONTROL					306	LPG CONTROL				
251	HEAD LIGHTS			✓	✓	307	LUBE OIL PUMP					307	LUBE OIL PUMP				
252	HEAD LIGHTS 2			✓	✓	308	MACERATOR PUMP			✓		308	MACERATOR PUMP			✓	✓
253	HEAD LIGHTS 3				✓	309	MAIN					309	MAIN				✓
254	HEAD LIGHTS 4				✓	310	MAIN BREAKER					310	MAIN BREAKER				✓
255	HEAD OUTLETS				✓	311	MAIN CABIN				✓	311	MAIN CABIN			✓	✓
256	HEADLIGHTS					312	MAIN CABIN LIGHTS			✓		312	MAIN CABIN LIGHTS			✓	✓
257	HEATER			✓		313	MAIN CABIN OUTLETS					313	MAIN CABIN OUTLETS			✓	
519	HEATER & AIR CONDITIONER					314	MAIN SAIL FURLING					314	MAIN SAIL FURLING				
258	HEATER 2			✓	✓	315	MAP LIGHT				✓	315	MAP LIGHT				✓
259	HEATER 3				✓	316	MAST LIGHTS				✓	316	MAST LIGHTS				✓
260	HEATER 4				✓	317	MASTHEAD LIGHT					317	MASTHEAD LIGHT				
261	HELM ELECTRONICS			✓	✓	318	MICROWAVE					318	MICROWAVE			✓	
262	HELM GAUGES			✓		319	MINI DISC PLAYER					319	MINI DISC PLAYER				
263	HELM INSTRUMENTS			✓		320	MIZZEN FLOOD					320	MIZZEN FLOOD				
264	HIGH WATER ALARM			✓		456	NAV LIGHT ANCHOR OFF NAV					456	NAV LIGHT ANCHOR OFF NAV				
265	HOLDING TANK			✓		321	NAV STATION ELECTRONICS				✓	321	NAV STATION ELECTRONICS				✓
266	HOLDING TANK ALARM			✓		322	NAV STATION GAUGES				✓	322	NAV STATION GAUGES				✓
267	HOLDING TANK PUMP			✓		323	NAV STATION INSTRUMENTS				✓	323	NAV STATION INSTRUMENTS				✓
268	HOOD FAN				✓	324	NAV STATION LIGHTS				✓	324	NAV STATION LIGHTS				✓
269	HOOD LIGHT					325	NAVIGATION ELECTRONICS				✓	325	NAVIGATION ELECTRONICS				✓
270	HORN	✓				326	NAVIGATION INSTRUMENTS				✓	326	NAVIGATION INSTRUMENTS				✓
475	HOT TUB					327	NAVIGATION LIGHTS				✓	327	NAVIGATION LIGHTS				✓
271	HOT WATER PUMP					328	NIGHT LIGHTS					328	NIGHT LIGHTS				
272	HYDRAULIC ALARM					329	OFF					329	OFF				
273	HYDRAULIC SYSTEM					331	OIL CHANGE PUMP					331	OIL CHANGE PUMP				
274	HYDRAULIC TANK ALARM					332	ON					332	ON				
275	ICE MAKER				✓	330	ON-OFF					330	ON-OFF				
276	IGNITION					333	OUTLETS					333	OUTLETS			✓	
277	IGNITION PORT					334	OUTLETS 2					334	OUTLETS 2				✓
278	IGNITION STBD					335	OUTLETS 3					335	OUTLETS 3				✓
279	INSTRUMENT LIGHTS			✓		336	OUTLETS 4					336	OUTLETS 4				✓
280	INSTRUMENTS			✓		505	OUTLETS AFT					505	OUTLETS AFT				
281	INTERCOM			✓		337	OUTLETS DECK					337	OUTLETS DECK				✓
282	INTERCOM HAILER					506	OUTLETS ENGINE ROOM					506	OUTLETS ENGINE ROOM				
283	INTERCOM/TELEPHONE					338	OUTLETS EXTERIOR					338	OUTLETS EXTERIOR				✓
284	INTERIOR LIGHTS			✓	✓	503	OUTLETS FORWARD					503	OUTLETS FORWARD				✓
285	INVERTER			✓		339	OUTLETS INTERIOR					339	OUTLETS INTERIOR				✓
467	INVERTER 2					504	OUTLETS PILOT HOUSE					504	OUTLETS PILOT HOUSE				
476	INVERTER AC BUS					458	PANEL LIGHTS					458	PANEL LIGHTS				
471	INVERTER AC SUPPLY					496	PILOT HOUSE FAN					496	PILOT HOUSE FAN				
470	INVERTER DC SUPPLY					340	PORT					340	PORT				
286	INVERTER OUTLET				✓	341	PORT THRUSTER					341	PORT THRUSTER				
287	ISOLATION TRANSFORMER				✓	342	POWER					342	POWER				
479	KITCHEN					343	POWER WASHER					343	POWER WASHER				
484	KITCHEN SLIDEOUT					457	PRE-HEAT					457	PRE-HEAT				
288	KNOTMETER	✓				344	PRIMARY WINCHES					344	PRIMARY WINCHES				
289	LAZARETTE LIGHTS				✓	345	PRINTER					345	PRINTER				
290	LECTRASAN				✓	346	PUMP					346	PUMP				
291	LIGHTER					497	PUMP BLACK WATER					497	PUMP BLACK WATER				
292	LIGHTS	✓		✓		498	PUMP GRAY WATER					498	PUMP GRAY WATER				
293	LIGHTS 2			✓	✓	347	RACK LIGHTS				✓	347	RACK LIGHTS				✓
294	LIGHTS 3				✓	348	RACK OUTLETS					348	RACK OUTLETS				✓
295	LIGHTS 4				✓	349	RADAR			✓		349	RADAR				
296	LIGHTS AFT				✓	350	RADAR ARCH LIGHTS					350	RADAR ARCH LIGHTS				
494	LIGHTS AFT CABIN					351	RADIO				✓	351	RADIO				✓
297	LIGHTS FWD				✓	352	RANGE					352	RANGE				✓
493	LIGHTS MASTER CABIN					353	RDF					353	RDF				
495	LIGHTS PANTRY					483	REAR SLIDEOUT					483	REAR SLIDEOUT				
492	LIGHTS PILOTHOUSE					354	RECEIVER					354	RECEIVER				
298	LIGHTS PORT					355	RECEPTACLE					355	RECEPTACLE				
491	LIGHTS SETTEE					356	REFRIGERATOR			✓		356	REFRIGERATOR			✓	

PANEL ACCESSORIES

LARGE FORMAT PANEL LABELS LISTING

REFRIGERATOR

Label Number	Description	8067 AC Extended			Label Number	Description	8067 AC Extended		
		8031 AC Basic		8039 DC Extended			8031 AC Basic		8039 DC Extended
		8030 DC Basic					8030 DC Basic		
357	REFRIGERATOR PUMP				518	TRANSFORMER SECONDARY			
358	REFRIGERATOR/FREEZER			✓	420	TRASH COMPACTOR			✓
359	REGULATOR				478	TRAVEL LOCKS			
360	REVERSE POLARITY			✓	421	TRICOLOR LIGHT	✓		
361	ROD LOCKER				422	TRIM TABS		✓	
489	RUDDER ANGLE INDICATOR				423	TV		✓	✓
362	RUNNING LIGHTS	✓			424	TV ANTENNA			
363	SAILING CONTROLS				425	TV/STEREO			✓
364	SAILING INSTRUMENTS	✓			426	TV/VCR		✓	
365	SALOON		✓	✓	427	UPS SYSTEM			✓
366	SALOON HEATER			✓	428	UTILITY		✓	
367	SALOON LIGHTS		✓	✓	429	VACUUM			✓
368	SALOON OUTLETS			✓	430	VACUUM PUMP			
369	SALT WATER PUMP				431	VCR			✓
370	SAT/COM		✓		432	VHF	✓		
371	SAT/NAV		✓		511	VHF 1			
372	SATELLITE DISH		✓	✓	512	VHF 2			
373	SCRUBBER				433	VIDEO PLOTTER		✓	
374	SEARCHLIGHT		✓		434	VIDEO SYSTEM			✓
375	SEARCHLIGHT HAND HELD				513	WASHDOWN PUMP			
376	SEARCHLIGHT REMOTE				435	WASHER			✓
377	SEAWATER TEMP		✓		436	WASHER/DRYER			✓
378	SEAWATER WASH DOWN		✓		437	WATER ALARM		✓	
379	SECURITY SYSTEM		✓		438	WATER HEATER			✓
380	SHIP			✓	439	WATER LEVEL			
381	SHORE			✓	440	WATER MAKER		✓	✓
463	SHORE 1				441	WATER PRESSURE	✓		
464	SHORE 2				442	WATER PUMP		✓	
382	SHORE CORD REEL				443	WEATHER FAX		✓	
383	SHORE POWER			✓	444	WEATHER INSTRUMENT		✓	
384	SHORE POWER CORD				445	WINCHES		✓	
385	SHOWER SUMP PUMP		✓		477	WIND GENERATOR			
386	SINK DRAIN				446	WIND INSTRUMENTS		✓	
486	SLIDEOUT				447	WINDEX LIGHT		✓	
387	SOLAR PANEL				448	WINDLASS			
388	SONAR		✓		522	WINDSHIELD VENT			
389	SPARE	✓		✓	449	WINDSHIELD WASHER			
390	SPEED/LOG		✓		472	WIPER CENTER			
391	SPREADER LIGHTS	✓			450	WIPER PORT		✓	
392	SPREADER LT MIZZEN				451	WIPER STBD		✓	
393	SSB		✓		452	WIPERS		✓	
394	STABILIZER								
395	STARBOARD								
396	START								
398	START PORT								
399	START STBD								
397	START-STOP								
400	STBD THRUSTER								
401	STEAMING LIGHT	✓							
402	STEP LIGHT								
403	STEREO	✓		✓					
404	STERN LIGHT								
509	STERN THRUSTER								
405	STOP								
406	STOVE			✓					
407	STOVE/MICROWAVE			✓					
408	STROBE LIGHT	✓							
409	SUB PANEL		✓	✓					
410	SUMP PUMP		✓						
411	SUMP PUMP 2								
412	SYNCHRO								
413	TAPE DECK								
414	TELEPHONE SYSTEM		✓	✓					
415	TEST								
416	TOWING LIGHTS								
417	TRACK LIGHTS		✓	✓					
465	TRANSFER								
418	TRANSFER PUMP		✓						
419	TRANSFORMER								

AC and DC Digital Meters

- DC Digital Meters for Voltage and Amperage
- AC Digital Meters for Voltage, Amperage, Frequency, and Watts
- Voltmeters, Ammeters, Frequency Meters, and Multimeters
- Easy spin on mounting system
- Readable in low light
- Can be rear or front panel mounted
- Direct replacement for analog meters
- Scan mode on multi-function units
- Low current drain

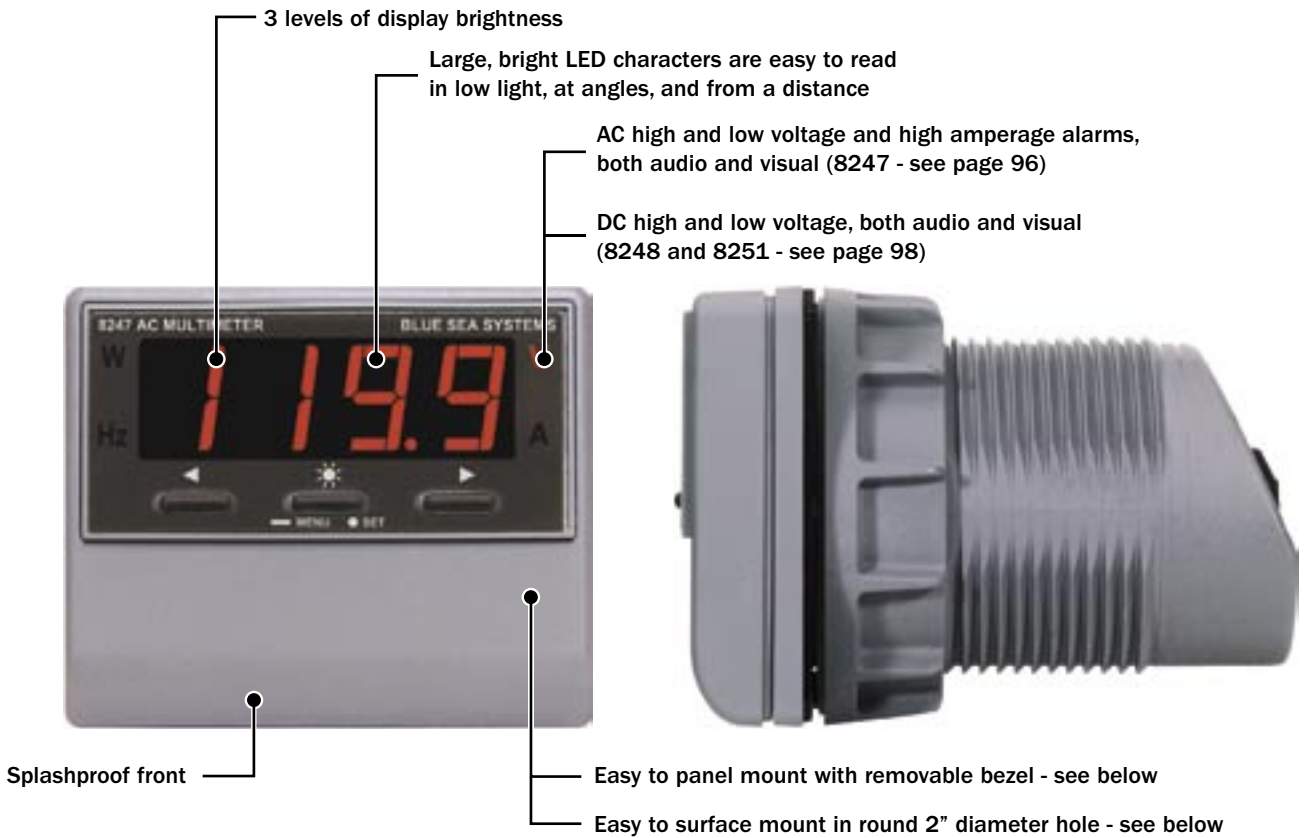

Digital Meter Front Panel Mount

Surface mounting features a finger nut and locking ring for quick and easy installation into a 2.00" (52.00mm) diameter hole.

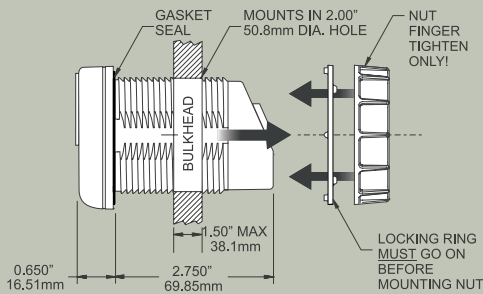

Digital Meter Rear Panel Mount

To panel mount simply remove the bezel and mount in any Blue Sea Systems full sized meter cutout

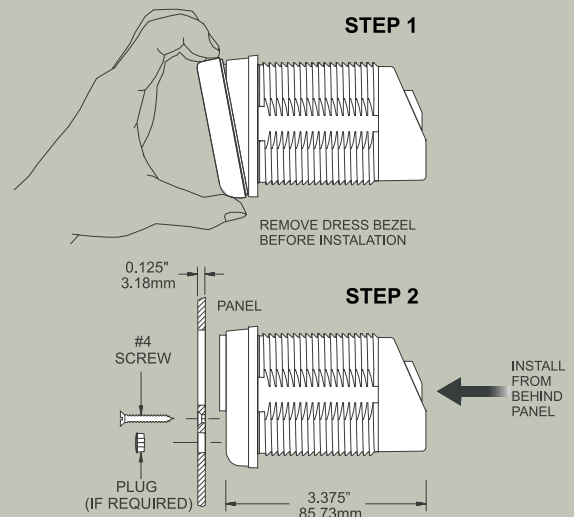

AC Digital Multimeter with Alarm

- Displays amperage from 0 to 150 Amperes
- Displays voltage from 80 to 270 Volts AC
- Displays power from 10 to 45 Kilowatts
- Displays frequency from 40 to 90 Hertz
- High and low voltage and high amperage alarms, both audio and visual
- 3 levels of display brightness
- Programmable sleep mode blanks display for power conservation
- Splashproof front
- Includes current transformer - reference 8256, (see page 103)

Specifications

Display Character Size	9/16" (14.29mm)
Input Voltage	80-270V AC*
Minimum Power Consumption	0.010 Watt**
Maximum Power Consumption	0.027 Watt**
Dimensions	Width 2.90" (73.56mm) Height 2.43" (61.75mm) Depth 3.40" (86.36mm)
Weight	0.78Lb (0.35Kg)

* For 120 & 240 Volt AC single phase systems

** Variable with voltage, display intensity, segments illuminated and sleep mode



8247

AC Digital Frequency Meter

- Displays frequency from 40 to 90 Hertz
- 3 levels of display brightness
- Splashproof front
- Manual sleep mode blanks display for power conservation

Specifications

Display Character Size	9/16" (14.29mm)
Input Voltage	80-270V AC*
Minimum Power Consumption	0.010 Watt**
Maximum Power Consumption	0.027 Watt**
Dimensions	Width 2.90" (73.56mm) Height 2.43" (61.75mm) Depth 3.40" (86.36mm)
Weight	0.72Lb (0.35Kg)

* For 120 & 240 Volt AC single phase systems

** Variable with voltage, display intensity, segments illuminated and sleep mode



8239

AC Digital Ammeter

- Displays amperage from 0 to 150 Amperes
- 3 levels of display brightness
- Splashproof front
- Includes current transformer - reference 8256, (see page 103)
- Manual sleep mode blanks display for power conservation

Specifications

Display Character Size	9/16" (14.29mm)
Input Voltage	80-270V AC*
Minimum Power Consumption	0.010 Watt**
Maximum Power Consumption	0.027 Watt**
Dimensions	Width 2.90" (73.56mm) Height 2.43" (61.75mm) Depth 3.40" (86.36mm)
Weight	0.78Lb (0.35Kg)

* For 120 & 240 Volt AC single phase systems

** Variable with voltage, display intensity, segments illuminated and sleep mode



8238



8237

AC Digital Voltmeter

- Displays voltage from 80 to 270 Volts AC
- 3 levels of display brightness
- Splashproof front
- Manual sleep mode blanks display for power conservation

Specifications

Display Character Size	9/16" (14.29mm)
Input Voltage	80-270V AC*
Minimum Power Consumption	0.010 Watt**
Maximum Power Consumption	0.027 Watt**
Dimensions	Width 2.90" (73.56mm)
	Height 2.43" (61.75mm)
	Depth 3.40" (86.36mm)
Weight	0.72Lb (0.33Kg)

- * For 120 & 240 Volt AC single phase systems
- ** Variable with voltage, display intensity, segments illuminated and sleep mode

AC Digital Meter Specifications

PN	Description	Current Measurement	Voltage Measurement	Frequency Measurement	Power Measurement
8247	AC Digital Multimeter with Alarm	✓	✓	✓	✓
8239	AC Digital Frequency Meter	-	-	✓	-
8238	AC Digital Ammeter	✓	-	-	-
8237	AC Digital Voltmeter	-	✓	-	-

<p>Current Measurement</p> <p>Current Transformer: 150A-50mV</p> <p>Range 1 (Resolution 0.01A): 0.00-9.99A AC (RMS)</p> <p>Range 2 (Resolution 0.10A): 10-150A AC (RMS)</p> <p>Accuracy (% of Reading): ±1.0%²</p>	<p>Frequency Measurement</p> <p>Range: 40-90Hz</p> <p>Resolution: 0.1Hz</p> <p>Accuracy (% of Reading): ±1.0%²</p> <p>(Calibrated with sine wave input)</p>
<p>Voltage Measurement</p> <p>Range: 80-270V AC¹</p> <p>Resolution: 0.1V AC</p> <p>Accuracy (% of Reading)</p> <p>90-270V AC (RMS): ±1.0%²</p> <p>80-90V AC (RMS): ±5.0%²</p>	<p>Power Measurement</p> <p>Range 1 (Resolution 10W): 0.00-9990W</p> <p>Range 2 (Resolution 0.1kW): 10-45kW</p> <p>Accuracy (% of Reading): ±5.0%²</p>

¹ For 120 & 240 Volt AC single phase systems

² ±1 least digit of resolution

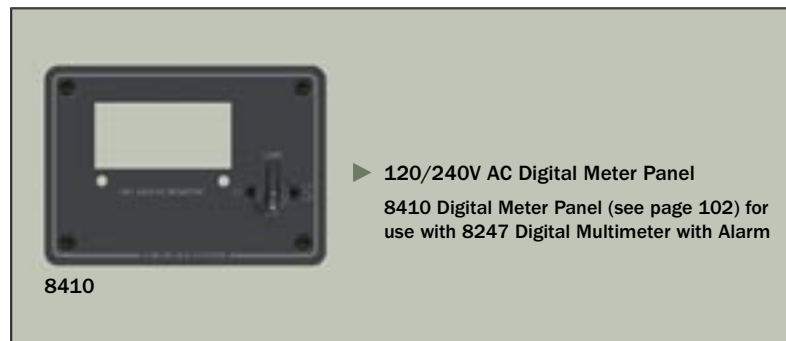
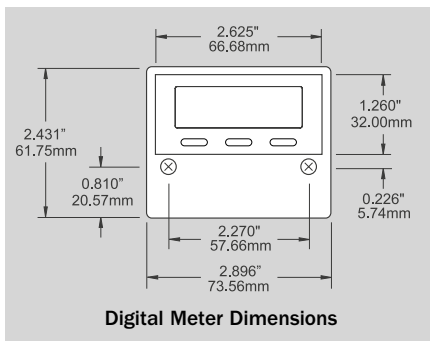

DC Digital Multimeter with Alarm

- Displays amperage from -500 to +500 Amperes
- Displays voltage from 0 to 60 Volts DC in 0.01 Volt increments
- High and low voltage, audio and visual alarms
- Standard meter operates in negative side of circuit only. Shunt shifter required for positive side installation such as alternators - reference 8242 (see page 103)
- 3 levels of display brightness
- Programmable sleep mode blanks display for power conservation
- Splashproof front
- Includes 500 Amp shunt - reference 8255 (see page 103)

Specifications

Display Character Size	9/16" (14.29mm)
Input Voltage	7-60V DC*
Minimum Power Consumption	0.60 Watt**
Maximum Power Consumption	1.00 Watt**
Dimensions	Width 2.90" (73.56mm) Height 2.43" (61.75mm) Depth 3.40" (86.36mm)
Weight	1.12Lb (0.51Kg)

* Applicable for 12, 24, 32, 36, and 42 Volt DC systems
 ** Variable with voltage, display intensity, segments illuminated and sleep mode



8248

DC Digital Voltmeter with Alarm

- Displays voltage from 0 to 60 Volts DC
- High and low voltage audio and visual alarms
- 3 levels of display brightness
- Programmable sleep mode blanks display for power conservation
- Splashproof front

Specifications

Display Character Size	9/16" (14.29mm)
Input Voltage	7-60V DC*
Minimum Power Consumption	0.60 Watt**
Maximum Power Consumption	1.00 Watt**
Dimensions	Width 2.90" (73.56mm) Height 2.43" (61.75mm) Depth 3.40" (86.36mm)
Weight	0.44Lb (0.20Kg)

* Applicable for 12, 24, 32, 36, and 42 Volt DC systems
 ** Variable with voltage, display intensity, segments illuminated and sleep mode



8251

DC Digital Voltmeter

- Displays voltage from 0 to 60 Volts DC
- 3 levels of display brightness
- Splashproof front
- Manual sleep mode blanks display for power conservation

Specifications

Display Character Size	9/16" (14.29mm)
Input Voltage	7-60V DC*
Minimum Power Consumption	0.60 Watt**
Maximum Power Consumption	1.00 Watt**
Dimensions	Width 2.90" (73.56mm) Height 2.43" (61.75mm) Depth 3.40" (86.36mm)
Weight	0.44Lb (0.20Kg)

* Applicable for 12, 24, 32, 36, and 42 Volt DC systems
 ** Variable with voltage, display intensity, segments illuminated and sleep mode



8235



8236

DC Digital Ammeter

- Displays amperage from -500 to +500 Amperes
- 3 levels of display brightness
- Splashproof front
- Manual sleep mode blanks display for power conservation
- Standard meter operates in negative side of circuit only. Shunt shifter required for positive side installation such as alternators - reference 8242 (see page 103)
- Includes 500 Ampere shunt - reference 8255 (see page 103)
- Manual sleep mode blanks display for power conservation

Specifications

Display Character Size	9/16" (14.29mm)
Input Voltage	7-60V DC*
Minimum Power Consumption	0.60 Watt**
Maximum Power Consumption	1.00 Watt**
Dimensions	Width 2.90" (73.56mm) Height 2.43" (61.75mm) Depth 3.40" (86.36mm)
Weight	1.12Lb (0.51Kg)

* Applicable for 12, 24, 32, 36, and 42 Volt DC systems

** Variable with voltage, display intensity, segments illuminated and sleep mode

DC Digital Meter Specifications

PN	Description	Current Measurement	Voltage Measurement
8248	DC Digital Multimeter with Alarm	✓	✓
8251	DC Digital Voltmeter with Alarm	-	✓
8235	DC Digital Voltmeter	-	✓
8236	DC Digital Ammeter	✓	-

Current Measurement		Voltage Measurement	
Shunt:	500A-50mV	Range:	0-60V DC
Range:	±500A DC	Resolution:	0.01V DC
Resolution (0.0-99.9):	0.1A DC	Accuracy (% of Reading)	±0.5% ¹
Resolution (100-500):	1.0A DC		
Accuracy (% of Reading):	±0.5% ¹		

¹ ±1 least digit of resolution

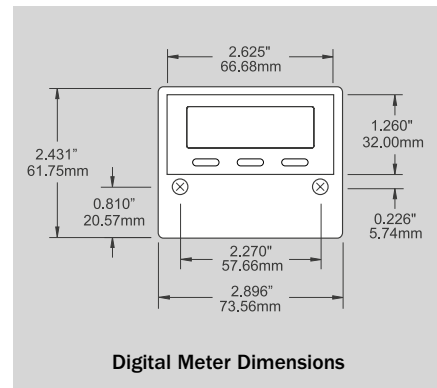

8403 with Digital Meter
(see page 46-47)



8678 with Digital Meter
(see page 45)

AC Analog Voltmeters

- Dial marked in 5 Volt increments
- Simple 2-wire connection to AC hot and neutral
- Meter senses and powers from same connection

Specifications

Accuracy ±2.5% of scale range

Standard Size 2-3/4" Face Meters		
PN	Description	Weight Lb (Kg)
9353	Voltmeter 0-150V AC	0.26 (0.12)
9354	Voltmeter 0-250V AC	0.26 (0.12)

Compact 2" Face Micro Meters		
PN	Description	Weight Lb (Kg)
8244	Micro Voltmeter 0-150V AC	0.19 (0.09)
8245	Micro Voltmeter 0-250V AC	0.19 (0.09)



9353



8245

AC Analog Ammeters

- 50 Amp dial marked in 2 Amperes increments
- Simple 2-wire connection
- Meter senses and powers from coil slipped over wire to be measured
- Includes AC current transformer (see page 103)

Specifications

Accuracy ±2.5% of scale range
 Meter Current 50 Milliamperes AC at full scale

Standard Size 2-3/4" Face Meters		
PN	Description	Weight Lb (Kg)
9630	Ammeter 0-50A AC + Transformer	0.32 (0.15)
8258	Ammeter 0-100A AC + Transformer	0.32 (0.15)

Compact 2" Face Micro Meter		
PN	Description	Weight Lb (Kg)
8246	Micro Ammeter 0-50A AC + Transformer	0.26 (0.12)



9630



8246

METERS AND ELECTRONIC CONTROLS

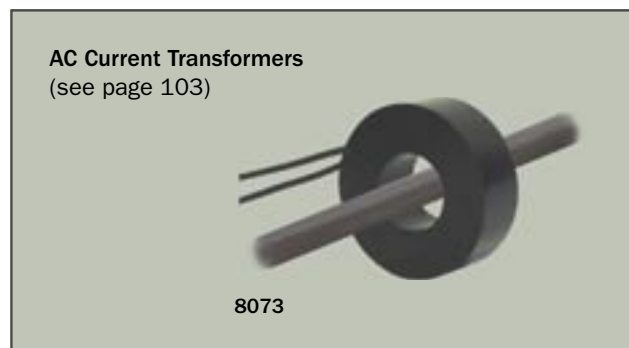
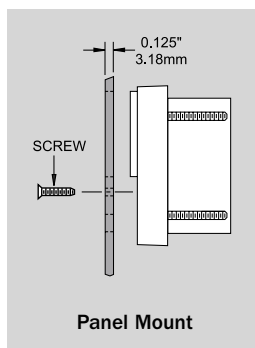
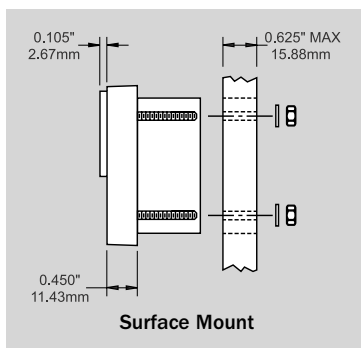
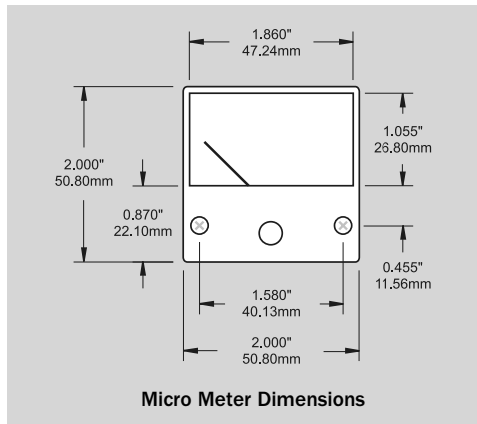
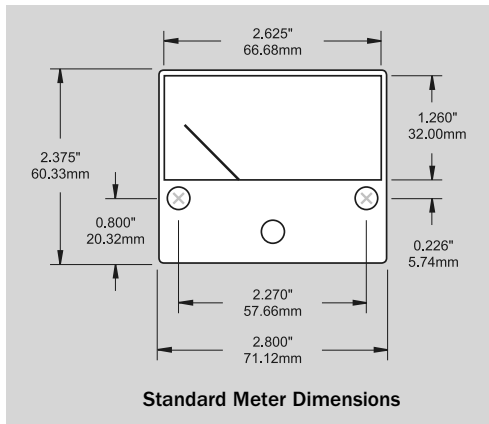

DC Analog Voltmeters

- Simple 2-wire connection

Specifications

Meter Current 1 Milliampere at full scale
 Accuracy ±2.5% of scale range



8240



8028

Standard Size 2-3/4" Face Meters		
PN	Description	Weight Lb (Kg)
8003	Voltmeter 8-16V DC	0.25 (0.11)
8240	Voltmeter 18-32V DC	0.25 (0.11)

Compact 2" Face Micro Meters		
PN	Description	Weight Lb (Kg)
8028	Micro Voltmeter 8-16V DC	0.19 (0.09)
8243	Micro Voltmeter 18-32V DC	0.19 (0.09)

DC Analog Ammeters

- Simple 2-wire connection from shunt - no other power required
 - Meter senses and powers from shunt connection
 - Includes DC shunt (see page 103)
- (Except 8005 and 8038 meters with internal shunts)

Specifications

External Shunt Type 50 Millivolt at meter full scale
 Meter Current 1 Milliampere at full scale
 Accuracy ±2.5% of scale range



8005



8041

Standard Size 2-3/4" Face Meters			
PN	Description	Shunt Type	Weight Lb (Kg)
8005	Ammeter 0-25A DC	Internal	0.26 (0.12)
8022	Ammeter 0-50A DC + Shunt	External	0.54 (0.24)
8016	Ammeter 0-75A DC + Shunt	External	0.54 (0.24)
8017	Ammeter 0-100A DC + Shunt	External	0.54 (0.24)
8018	Ammeter 0-150A DC + Shunt	External	0.54 (0.24)
8019	Ammeter 0-200A DC + Shunt	External	0.54 (0.24)

Compact 2" Face Micro Meters			
PN	Description	Shunt Type	Weight Lb/Kg
8038	Micro Ammeter 0-15A DC	Internal	0.20 (0.09)
8041	Micro Ammeter 0-50A DC + Shunt	External	0.40 (0.18)
8250	Micro Ammeter 0-100A DC + Shunt	External	0.40 (0.18)

DC Analog Zero Center Ammeters

- Meters read both discharge and charge current
- Simple 2-wire connection from shunt - no other power required
- Meter senses and powers from shunt connection
- Includes DC shunt (see page 103)

Specifications

External Shunt Type 50 Millivolt at meter full scale
 Meter Current 1 Milliampere at full scale
 Accuracy ±2.5% of scale range



8253



8254

Standard Size 2-3/4" Face Meters			
PN	Description	Shunt Type	Weight Lb (Kg)
8252	Ammeter 50-0-50A DC +Shunt	External	0.54 (0.24)
8253	Ammeter 100-0-100A DC +Shunt	External	0.54 (0.24)

Compact 2" Face Micro Meter			
PN	Description	Shunt Type	Weight Lb (Kg)
8254	Ammeter 50-0-50A DC +Shunt	External	0.40 (0.18)

DC Shunts power
 Blue Sea Systems
 DC Ammeters with
 external shunt
 (see page 103).



9228

120/240V AC Digital Meter Panel

- Perfect solution for monitoring 120/240 Volt AC systems
- Monitor Line 1 or Line 2 to Neutral and Line 1 to Line 2 voltages
- Monitor 120 Volt and 240 Volt currents
- Intended for use with 8247 AC Digital Multimeter (Not included) (see page 96)
- Includes two additional Current Transformers 8256 (see page 103)

Specifications

8247 AC Digital Multimeter See page 96
 Dimensions 5.25" (133.35mm) x 3.75" (95.25mm)

PN	Description
8410	120/240V AC Digital Meter Panel



8410

DC Voltmeter Panel

- 8003 DC Analog Voltmeter (see page 101)
- 8-16 Volts DC
- 3 position switch for multiple battery banks
- Full-size 2-3/4" meter

Specifications

Voltage 16 Volts DC Maximum
 Dimensions 5.25" (133.35mm) x 3.75" (95.25mm)

PN	Description	Weight Lb (Kg)
8015	Panel with Analog Voltmeter	0.49 (0.22)



8015

DC Digital Voltmeter Panel

- 8235 DC Digital Meter (see page 98)
- 7-60 Volts DC
- 4 digit display
- Full-size 2-3/4" meter

Specifications

Voltage 60 Volts DC Maximum
 Dimensions 5.25" (133.35mm) x 3.75" (95.25mm)

PN	Description	Weight Lb (Kg)
8051	Panel with Digital Voltmeter	0.64 (0.29)



8051

Meter Mounting Panels

- Surface mounts Blue Sea Systems 2-3/4" Analog or Digital Meters

Specifications

Panel Material 0.125" Aluminum 5052 Alloy
 Panel Undercoating Chemical Treatment
 Mil-C-5541C or equivalent
 Panel Front Coating Two part polyurethane slate gray finish
 Dimensions 8013 5.25" (133.35mm) x 3.75" (95.26mm)
 Dimensions 8014 5.25" (133.35mm) x 7.50" (190.50mm)

PN	Description	Weight Lb (Kg)
8013	Mounting Panel For (1) 2-3/4" Meter	0.22 (0.10)
8014	Mounting Panel For (2) 2-3/4" Meters	0.36 (0.16)



8014



8013



8255



9228

DC Shunts

- Power all Blue Sea Systems external shunt, DC ammeters
- For continuous operation, it is recommended that shunts not be run at more than two-thirds (66%) the rated current under normal conditions

Specifications

Shunt Type	Resistive, Manganin Metal Element
Full Scale Resistance	50 Millivolts
Accuracy	±0.25% Rated Current
Continuous Duty	66% of Rated Current
Intermittent Duty	100% - 5 Minutes 300% - 3 Seconds

PN	Description	Weight Lb (Kg)
9228	Analog Meter Shunt 50A/50mV	0.20 (0.09)
9229	Analog Meter Shunt 75A/50mV	0.20 (0.09)
9230	Analog Meter Shunt 100A/50mV	0.20 (0.09)
9231	Analog Meter Shunt 150A/50mV	0.20 (0.09)
9233	Analog Meter Shunt 200A/50mV	0.71 (0.32)
8255	Digital Meter Shunt 500A/50mV	0.71 (0.32)

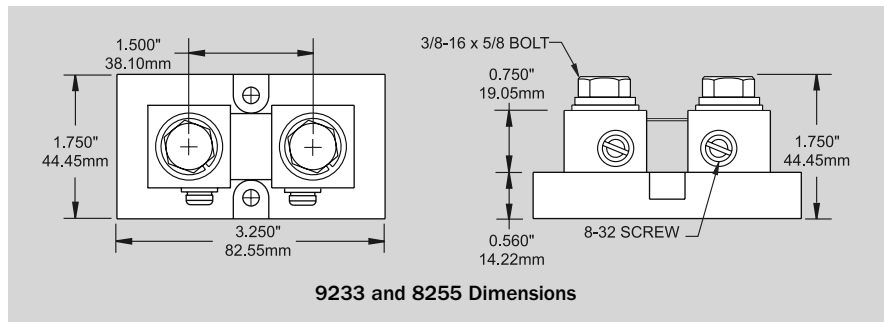
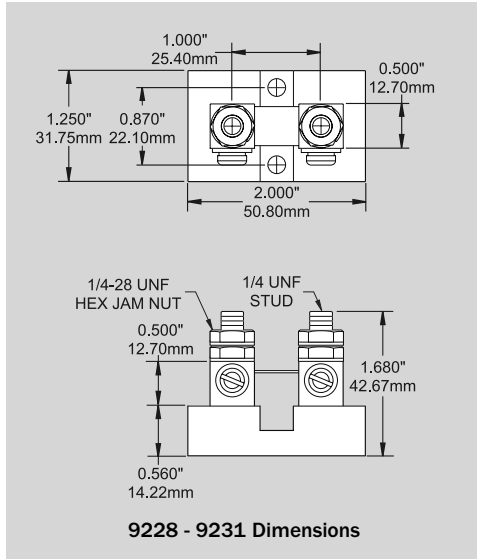

8242

Shunt Shifter

- Shunt adapter for DC Digital Ammeter positive side shunt applications, such as alternator measurement
- The Shunt Shifter is designed for use with Blue Sea Systems 8255 Digital Meter Shunt
- Advanced technology shifts the shunt's positive reference to negative as required by digital meters
- Easily installs directly onto shunt using existing sense screws
- Ideal for use with 12-36 Volt DC systems
- Includes all necessary hardware

PN	Description	Weight Lb (Kg)
8242	Shunt Adapter for DC Digital Ammeter	0.42 (0.02)

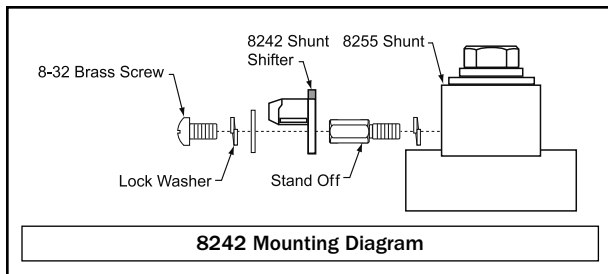

8073

AC Current Transformers

- For use with AC meters

Specifications

Dimensions	0.60" (15.24mm) Inside Diameter 1.38" (35.05mm) Outside Diameter
Accuracy	±1%

PN	Description	Ratio	Weight Lb (Kg)
8073	Analog Ammeter	50A AC/50mA AC	0.20 (0.09)
8257	Analog Ammeter	100A AC/50mA AC	0.20 (0.09)
8256	Digital Ammeter	150A AC/50mA AC	0.20 (0.09)

2 Ampere Digital Dimmer

- Continuous voltage control from 0 to 100% of input voltage
- Last setting memory - Power returns to previous setting with optional ON/OFF switch
- -20°C to +85°C operating temperature range
- Water resistant, sealed housings
- Operates on 10 to 32 Volt DC systems
- Rated for dashboard gauge or small single fixture interior dimming
- Small fans

Specifications

Surge Rating: 10 sec 5 Amperes
 Internal Over Current Protection 10 Amperes
 Draw 0% output 5mA (0.005A)

PN	Continuous Rating	Width in" (mm)	Height in" (mm)	Depth in" (mm)	Weight Lb (Kg)
7501	2A	1.67 (42.42)	2.05 (52.07)	1.50 (38.10)	0.35 (0.16)



7501

5 Ampere Digital Dimmer

- Continuous voltage control from 0 to 100% of input voltage
- Last setting memory - Power returns to previous setting with optional ON/OFF switch
- -20°C to +85°C operating temperature range
- Water resistant, sealed housings
- Operates on 10 to 32 Volt DC systems
- Rated for medium to large single fixture interior dimming
- Most fans and small blowers

Specifications

Surge Rating: 10 sec 10 Amperes
 Internal Over Current Protection 20 Amperes
 Draw 0% output 5mA (0.005A)

PN	Continuous Rating	Width in" (mm)	Height in" (mm)	Depth in" (mm)	Weight Lb (Kg)
7502	5A	2.16 (54.86)	3.06 (77.72)	1.60 (40.64)	0.62 (0.28)



7502

10 Ampere Digital Dimmer

- Continuous voltage control from 0 to 100% of input voltage
- Last setting memory - Power returns to previous setting with optional ON/OFF switch
- -20°C to +85°C operating temperature range
- Water resistant, sealed housings
- Operates on 10 to 32 Volt DC systems
- Rated for multiple fixture area lighting dimming
- Large fans and blowers
- Robust aluminum housing

Specifications

Surge Rating: 10 sec 25 Amperes
 Internal Over Current Protection 50 Amperes
 Draw 0% Output 5mA (0.005A)

PN	Continuous Rating	Width in" (mm)	Height in" (mm)	Depth in" (mm)	Weight Lb (Kg)
7503	10A	2.16 (54.86)	3.06 (77.72)	1.60 (40.64)	0.97 (0.44)



7503

20 Ampere Digital Dimmer

- Continuous voltage control from 0 to 100% of input voltage
- Last setting memory - Power returns to previous setting with optional ON/OFF switch
- -20°C to +85°C operating temperature range
- Water resistant, sealed housings
- Operates on 10 to 32 Volt DC systems
- Rated for multiple fixture area lighting dimming
- Large fans and blowers
- Robust aluminum housing

Specifications

Surge Rating: 10 sec 50 Amperes
 Internal Over Current Protection 70 Amperes
 Draw 0% Output 5mA (0.005A)

PN	Continuous Rating	Width in" (mm)	Height in" (mm)	Depth in" (mm)	Weight Lb (Kg)
7505	20A	2.16 (54.86)	3.06 (77.72)	1.60 (40.64)	1.10 (0.50)



7505



8216



8291

► For use with Blue Sea Systems DC Digital Dimmers (page 104)

Water Resistant Contura Switches

- Mounts in Blue Sea Systems water resistant panels
- Legend - BRIGHT and DIM
- Contura switch mounting panel and accessories (see page 55)

Specifications

Rating: 12 Volts DC	20 Amperes
Rating: 24 Volts DC	15 Amperes
Terminal Size	0.25" (6.35mm)
Terminal Type	Quick Connect Tab
Seals	Internal and External Gasket Panel Seal
Temperature Rating	-40°C to 85°C
Mounting Hole	1.45" (36.83mm) x 0.83" (21.08mm)

PN	Color	Pole/Throw	Action
8216	Gray	Single/Double	(ON)-OFF-(ON)
8291	Black	Single/Double	(ON)-OFF-(ON)



8208

► For use with Blue Sea Systems DC Digital Dimmers (page 104)

Toggle Panel Switch

- Mounts in Blue Sea Systems toggle panels

Specifications

Voltage 250 Volts AC	10 Amperes
Voltage 125 Volts AC	15 Amperes
Voltage 32 Volts AC	15 Amperes
Terminal Size	0.25" (6.35mm)
Terminal Type	Quick Connect Tab
Actuator Color	White

PN	Poles/Throw	Action	Weight Lb (Kg)
8208	Single/Double	(ON)-OFF-(ON)	0.42 (0.02)

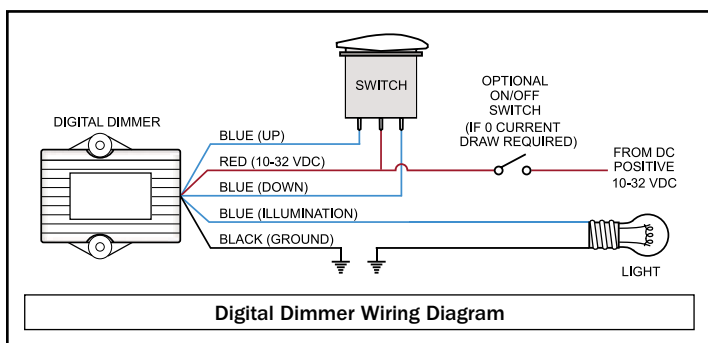

Updated Version Available January, 2006

Redesign of Popular 2301 150 Ampere BusBar

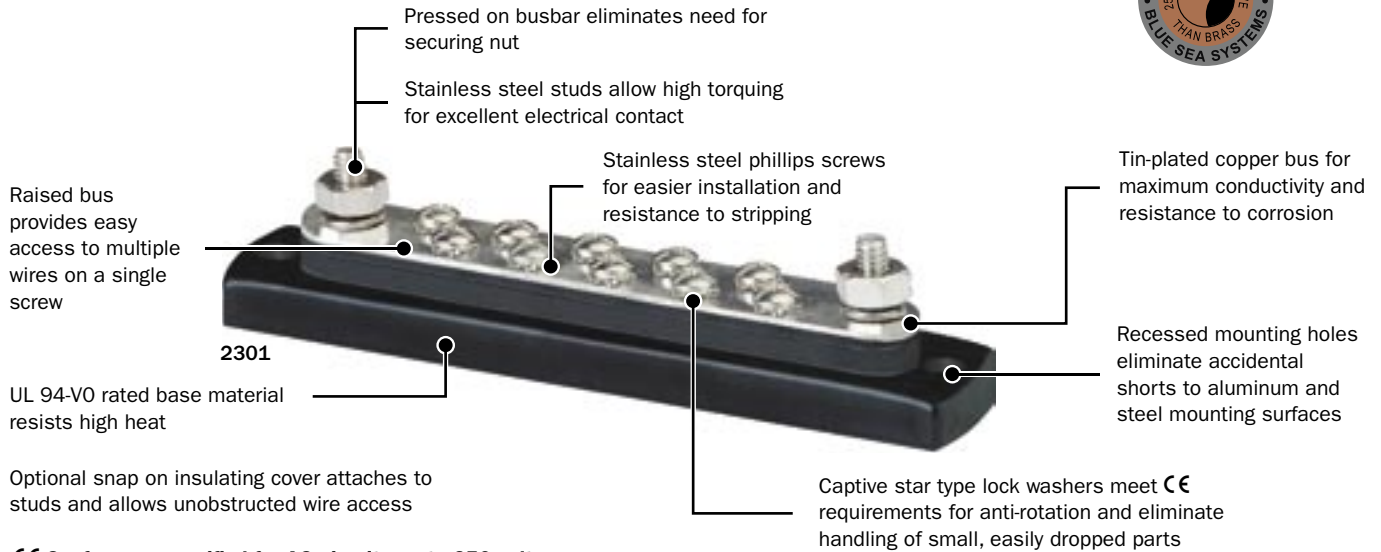

CE Conformance verified for AC circuits up to 250 volts

MiniBus 100 Ampere Common BusBars

• Great for limited space applications



Specifications

Continuous Amperage	100 Amperes AC/DC
Voltage Rating	300 Volts AC Maximum/48 Volts DC Maximum
Bus Material	Tin-Plated Copper CDA 110/UNS11000
Base Material	ABS
Cover Material	ABS

PN	Description	Weight Lb (Kg)
2304	5 x 8-32 Screw Terminal	0.14 (0.06)
2305	4 x 10-32 Stud Terminal	0.15 (0.07)
2306	Grounding BusBar 6 x 8-32 Screw Terminal	0.08 (0.04)
2714	Cover For MiniBus 2304 and 2305	0.03 (0.01)



2304 CE



2305 CE



2306



2714

CONNECTORS

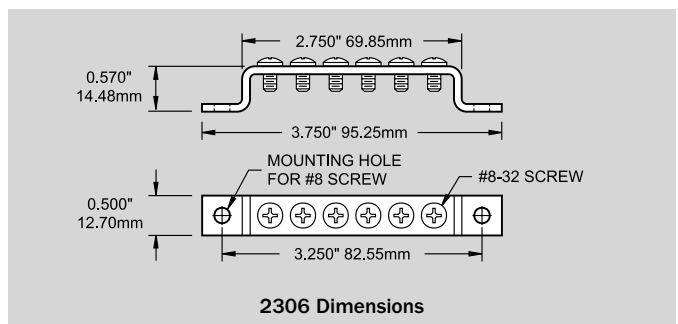
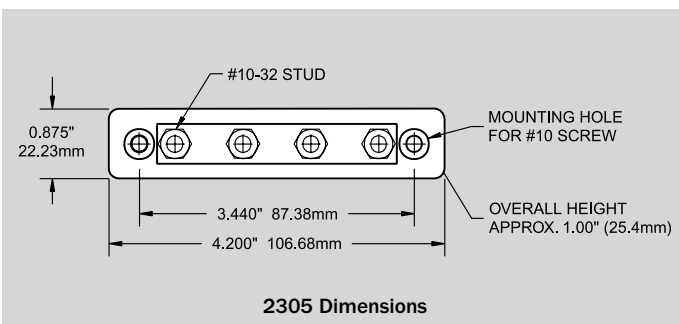
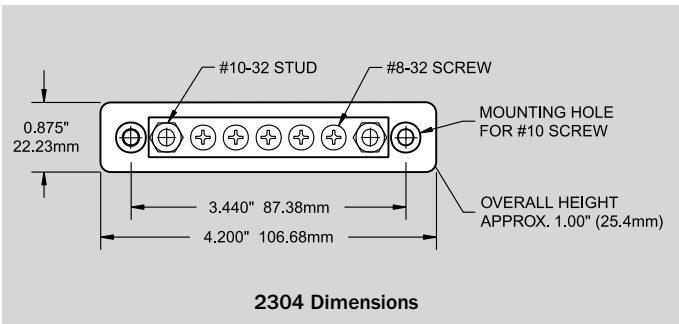



DualBus 100 Ampere Common BusBars

- Combines negative and positive buses on one block

Specifications

Continuous Amperage 100 Amperes AC/DC
 Voltage Rating 300 Volts AC Maximum/48 Volts DC Maximum
 Bus Material Tin-Plated Copper CDA 110/UNS11000
 Base Material ABS
 Cover Material ABS
 CE marked



2701



2702

PN	Description	Weight Lb (Kg)
2701	5 x 8-32 Screw Terminal	0.17 (0.08)
2702	10 x 8-32 Screw Terminal	0.27 (0.12)

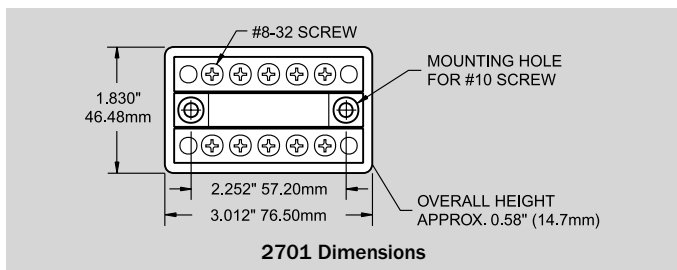

2701 Dimensions

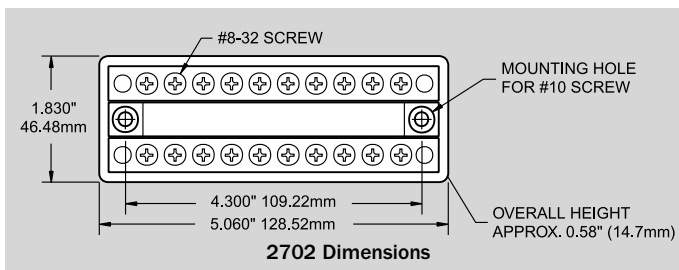

2702 Dimensions

Cover For DualBus 100 Ampere Common BusBars

Specifications

Cover Material ABS



2709



2710

PN	Description	Weight Lb (Kg)
2709	Cover For DualBus 2701	0.04 (0.02)
2710	Cover For DualBus 2702	0.05 (0.02)

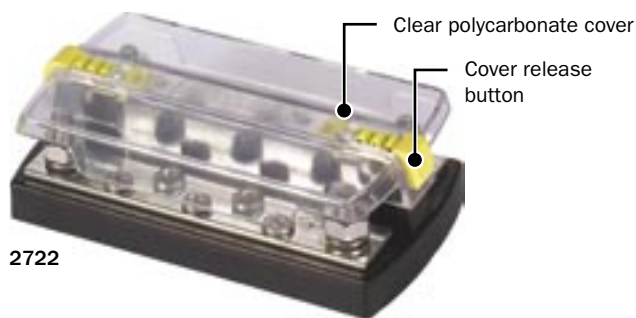

2722

DualBus Plus

- Combines negative and positive buses on one block
- Clear polycarbonate cover snaps on to meet Coast Guard and ABYC insulation requirements

Specifications

Continuous Amperage 130 Amperes AC/150 Amperes DC
 Voltage Rating 300 Volts AC Maximum/48 Volts DC Maximum
 Bus Material Tin-Plated Copper CDA 110/UNS11000
 Base Material Reinforced Polycarbonate
 Cover Material Clear Polycarbonate



PN	Description	Weight Lb (Kg)
2720	1/4" Stud	0.61 (0.28)
2722	1/4" Stud, 5 x 10-32 Screw Terminal	0.61 (0.28)
2723	5/16" Stud, 5 x 10-32 Screw Terminal	0.61 (0.28)

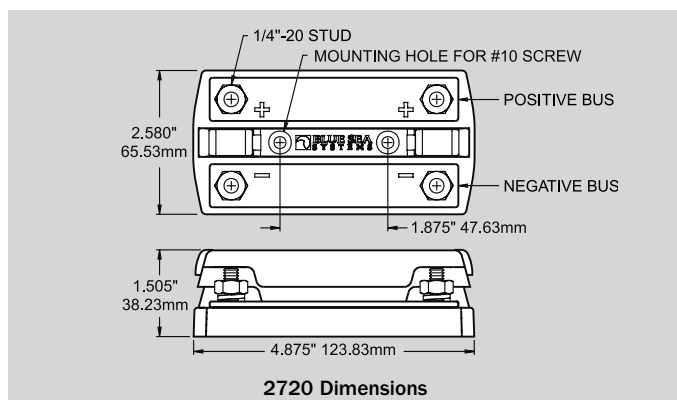

2720 Dimensions

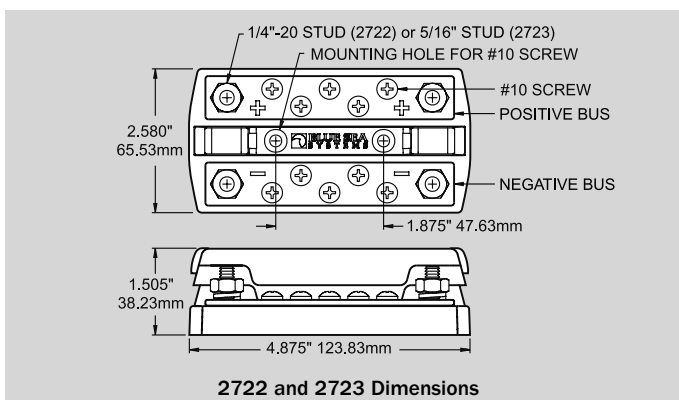

2722 and 2723 Dimensions

150 Ampere Common BusBars

- The industry standard busbar for positive distribution (2301)
- The industry standard busbar for the collection of negative or AC ground circuits (2301)



Specifications

Continuous Amperage	130 Amperes AC 150 Amperes DC
Voltage Rating	300 Volts DC Maximum 48 Volts DC Maximum
Bus Material	Tin-Plated Copper CDA 110/UNS11000
Base Material	Reinforced Nylon

CE marked

PN	Description	Weight Lb (Kg)
2300	10 x 8-32 Screw Terminal with Cover	0.34 (0.15)
2301	10 x 8-32 Screw Terminal	0.28 (0.13)
2302	20 x 8-32 Screw Terminal	0.40 (0.18)
2303	4 x 1/4" Stud Terminal	0.34 (0.15)

NEW PRODUCT

UPDATED PRODUCT

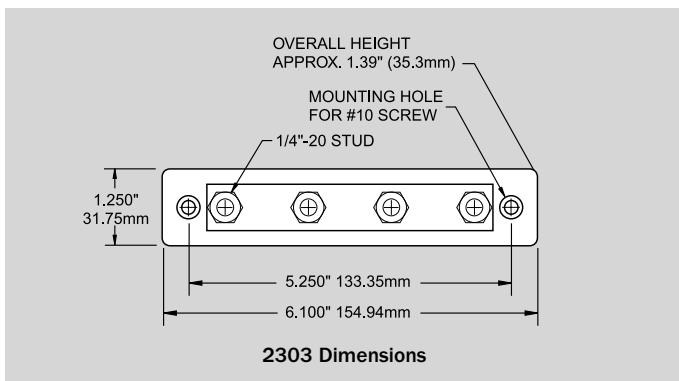
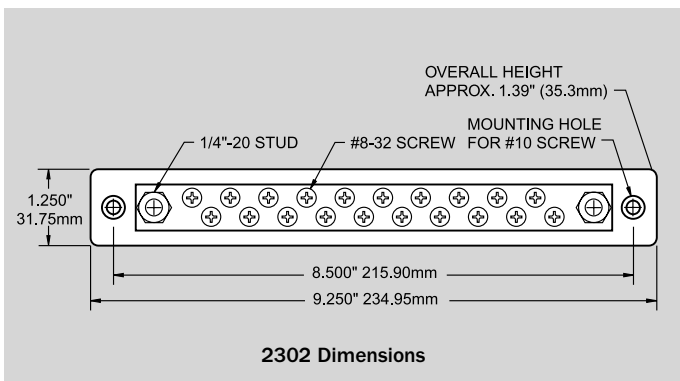
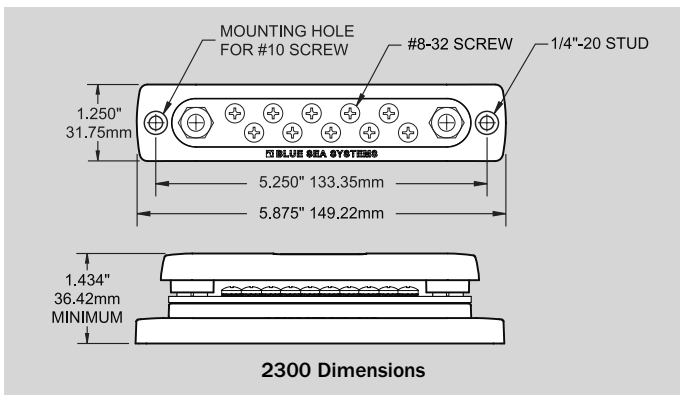

CONNECTORS

Covers For 150 Ampere Common BusBars

Specifications

Cover Material ABS

PN	Description	Weight Lb (Kg)
2715	Cover For BusBar 2301 and 2303	0.07 (0.03)
2707	Cover For BusBar 2302	0.06 (0.03)

NEW PRODUCT

Note: 2715 replaces 2706





MaxiBus 250 Ampere Common BusBars

Specifications

Continuous Amperage 250 Amperes AC/DC
 Voltage Rating 300 Volts AC Maximum
 48 Volts DC Maximum
 Bus Material Tin-Plated Copper CDA 110/UNS11000
 Base Material Reinforced Polycarbonate

CE marked



2105



2106

PN	Description	Weight Lb (Kg)
2105	12 x #10-32 Terminal Screws	0.17 (0.08)
2106	4 x 5/16" Stud Terminals	0.27 (0.12)

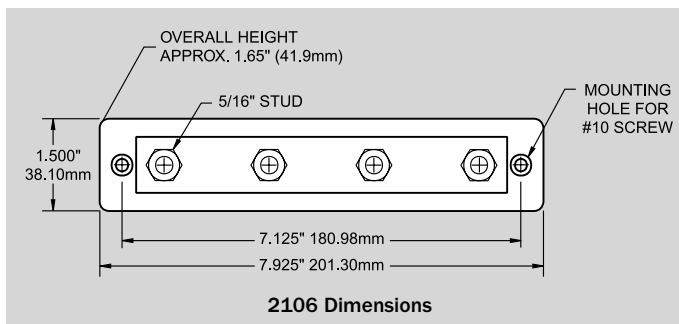
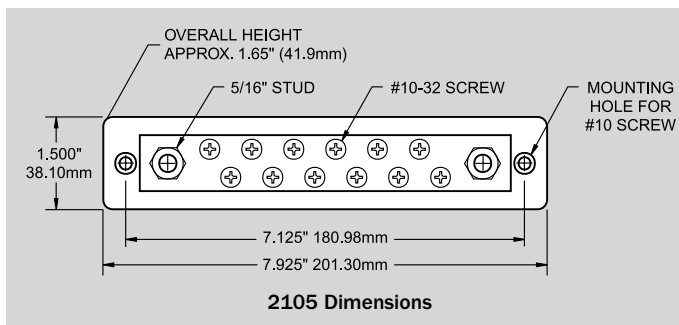

2711

Cover For MaxiBus 250 Ampere Common BusBars

Specifications

Cover Material ABS

PN	Description	Weight Lb (Kg)
2711	Cover For MaxiBus 2105 and 2106	0.06 (0.03)



Squalicum Harbor - Bellingham, Washington

PowerBar 600 Ampere Cable Connectors



Specifications

Continuous Amperage	545 Amperes AC 600 Amperes DC
Voltage Rating	300 Volts AC Maximum 48 Volts DC Maximum
Bus Material	Tin-Plated Copper CDA 110/UNS11000
Base Material	Reinforced Polycarbonate
CE marked	

PN	Description	Weight Lb (Kg)
2104	4 x 3/8-16 Stud Terminal	1.71 (0.78)
2107	8 x 3/8-16 Stud Terminal	3.42 (1.55)



2104



2107

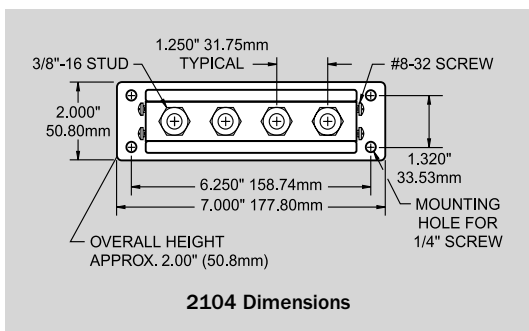

2104 Dimensions

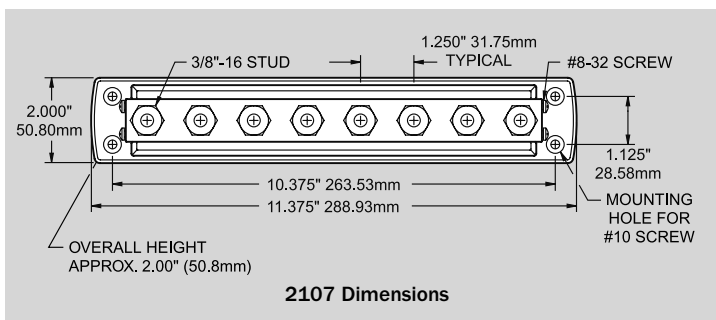

2107 Dimensions

Cover For 600 Ampere Cable Connector

Specifications

Cover Material	ABS
----------------	-----

PN	Description	Weight Lb (Kg)
2708	Cover For PN 2104	0.09 (0.04)



2708



2104 with 1 AWG Cables

20 Ampere Terminal Blocks

- Closed back design completely insulates power from the mounting surface
- Each screw pair is 1 isolated circuit
- Jumpers allow creation of common circuits (9218 - see page 112)

Specifications

Bus Material Nickel-Plated Brass
 Base Material Nylon
 Screw Size #6
 Continuous Rating 20 Amperes AC/DC
 Voltage Rating 300 Volts AC/DC Maximum

CE marked

PN	Circuit	Weight Lb (Kg)	[A] in" (mm)	[B] Length in" (mm)
2402	2	0.05 (0.02)	1.13 (28.70)	1.41 (35.70)
2404	4	0.06 (0.03)	1.88 (47.73)	2.16 (54.76)
2406	6	0.08 (0.04)	2.63 (66.80)	2.91 (73.82)
2408	8	0.10 (0.05)	3.38 (85.85)	3.66 (92.88)
2410	10	0.13 (0.06)	4.13 (104.90)	4.41 (111.94)

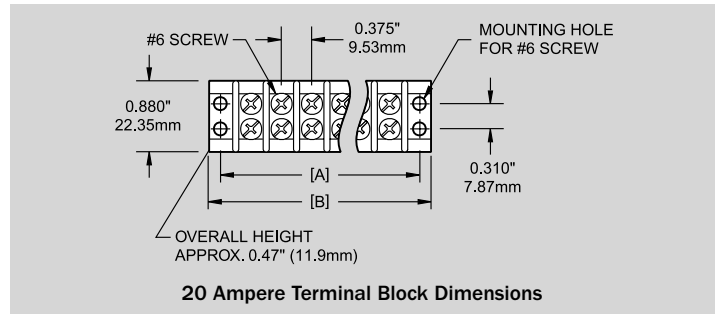
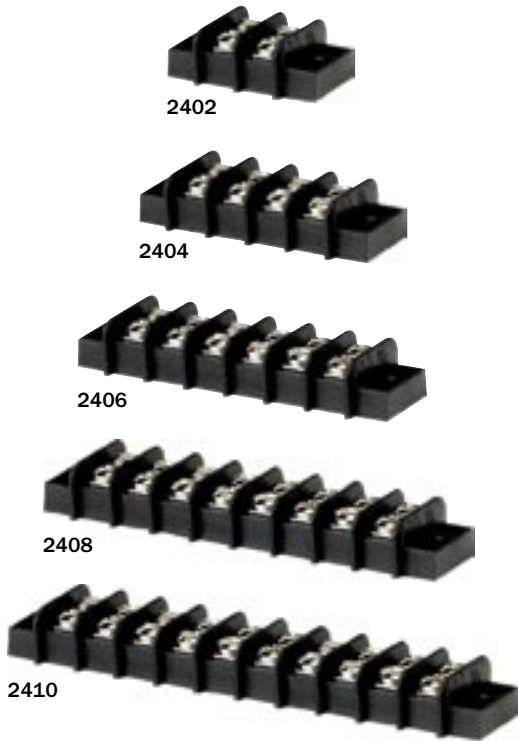

30 Ampere Terminal Blocks

- Closed back design completely insulates power from the mounting surface
- Each screw pair is 1 isolated circuit
- Jumpers allow creation of common circuits (9217 - see page 112)

Specifications

Bus Material Nickel-Plated Brass
 Base Material Phenolic
 Screw Size #8
 Continuous Rating 30 Amperes AC/DC
 Voltage Rating 600 Volts AC/DC Maximum

CE marked

PN	Circuit	Weight Lb (Kg)	[A] in" (mm)	[B] Length in" (mm)
2502	2	0.11 (0.05)	1.69 (42.93)	2.10 (59.35)
2504	4	0.15 (0.07)	2.81 (71.37)	3.22 (87.79)
2506	6	0.21 (0.10)	3.93 (99.82)	4.34 (116.23)
2508	8	0.27 (0.12)	5.05 (128.27)	5.46 (144.67)
2510	10	0.33 (0.15)	6.17 (156.72)	6.58 (173.11)
2512	12	0.44 (0.20)	7.29 (185.17)	7.70 (201.55)

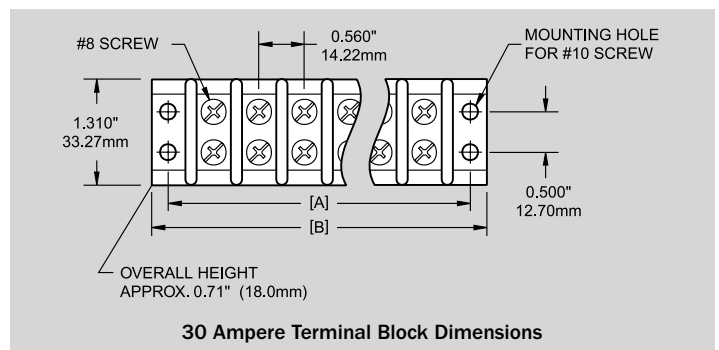

CONNECTORS

65 Ampere Terminal Blocks

- Closed back design completely insulates power from the mounting surface
- Each screw pair is 1 isolated circuit
- Jumpers allow creation of common circuits (9216 - see below)

Specifications

Bus Material Nickel-Plated Brass
 Base Material Phenolic
 Screw Size #10
 Continuous Rating 65 Amperes AC/DC
 Voltage Rating 600 Volts AC/DC Maximum

CE marked

PN	Circuit	Weight Lb (Kg)	[A] in" (mm)	[B] Length in" (mm)
2602	2	0.15 (0.07)	2.06 (52.32)	2.50 (63.49)
2604	4	0.23 (0.11)	3.44 (87.38)	3.88 (98.55)
2606	6	0.34 (0.16)	4.82 (122.43)	5.26 (133.61)
2608	8	0.43 (0.20)	6.20 (157.48)	6.64 (168.67)
2610	10	0.52 (0.24)	7.58 (192.53)	8.02 (203.73)

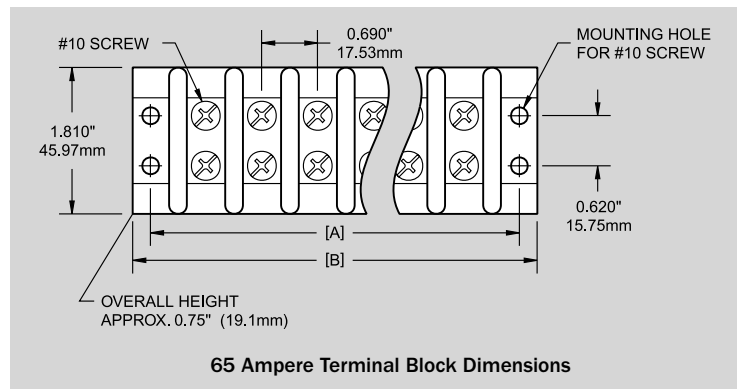

Terminal Block Jumpers

- Jumpers allow creation of common circuits on independent connectors
- 9218 - Fits 20 Ampere terminal blocks (2400 Series)
- 9217 - Fits 30 Ampere terminal blocks (2500 Series)
- 9216 - Fits 65 Ampere terminal blocks (2600 Series)

Specifications

Bus Material Nickel-Plated Brass
 Continuous Amperage Equivalent to matching block

PN	Description	Weight Lb (Kg)
9218	Terminal Block Jumpers for 2400 Series	0.03 (0.01)
9217	Terminal Block Jumpers for 2500 Series	0.04 (0.02)
9216	Terminal Block Jumpers for 2600 Series	0.05 (0.03)

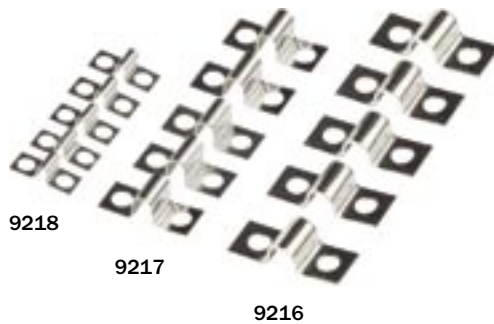

CONNECTORS

Euro Style Terminal Blocks

- Stainless Steel pressure plates meet ABYC requirements for stranded wire connections without the use of crimp-on terminals
- Strips are easily cut to required length
- Screw and pressure plate construction meet ABYC pull-out strength requirements
- Nylon insulating body meets ABYC and USCG insulating requirements without the use of external covers

Specifications

Bus Body	Nickel-Plated Brass
Clamping Screw Material	Nickel-Plated Brass
Wire protection pressure plate	Stainless Steel
Body Material	Polyamide 6 Nylon
Voltage Rating	600 Volts AC/DC Maximum
Wire Size Range PN 28XX	12-18 AWG
Wire Size Range PN 29XX	8-14 AWG
Continuous Rating PN 28XX	27 Amperes
Continuous Rating PN 29XX	45 Amperes

CE marked



27 Ampere Euro Style Connectors			
PN	Position	Weight Lb (Kg)	Length in" (mm)
2804	4	0.06 (0.14)	1.46 (37.00)
2808	8	0.09 (0.20)	3.03 (77.00)
2812	12	0.12 (0.26)	4.61 (117.00)

45 Ampere Euro Style Connectors			
PN	Position	Weight Lb (Kg)	Length in" (mm)
2904	4	0.11 (0.23)	1.46 (37.00)
2908	8	0.18 (0.39)	3.61 (91.70)
2912	12	0.25 (0.55)	5.47 (138.93)

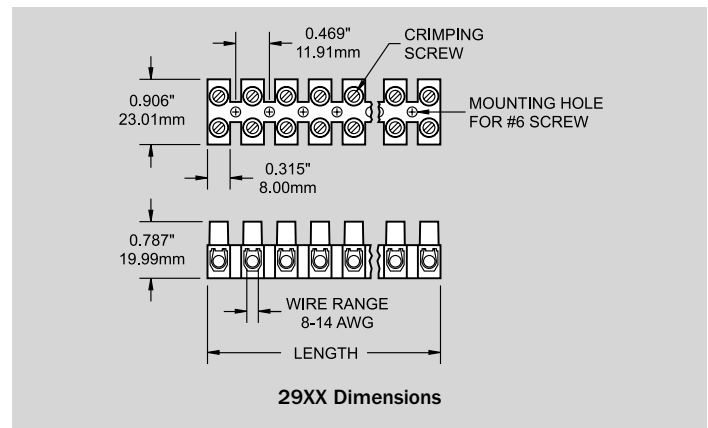
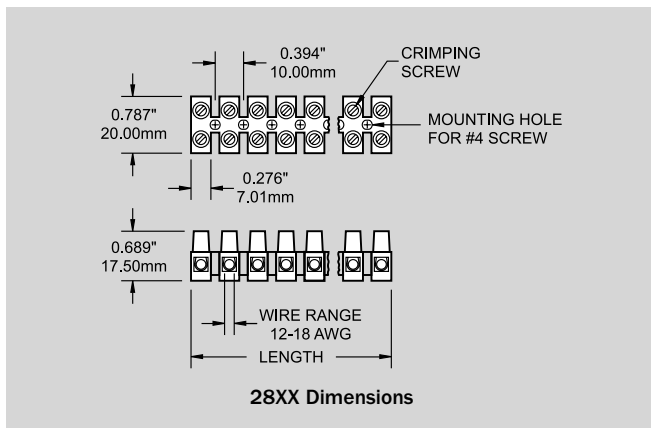

Pressure Connections vs. Crimp Terminal Connections

The majority of the terminations performed in marine applications are crimped barrel style. This has come to be the preferred termination method due to the high vibration environment and the fine strand of marine wire. However, pressure terminations are superior to barrel crimp terminations in marine situations where either very small wires are being used or where high quality ratcheting wire crimpers are not available.

If a pressure connector is used, it is crucial that it meets ABYC standards.

ABYC E-11.16.3.5 Connections may be made using a set screw pressure type conductor, providing a means is used to prevent the set screw from bearing directly on the conductor strands.

A well constructed pressure connector meeting ABYC Standards has the following attributes of Blue Sea Systems Euro Style Connectors:

Pressure plates protect delicate wire strands from cutting action of terminal screw. Stainless steel pressure plates are non-corrosive and exert uniform pressure to meet ABYC pull-out requirements

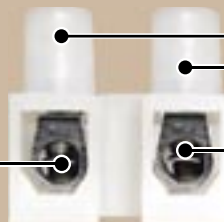

Nylon body meets ABYC and USCG requirements for insulation

Nickel-plated brass screw and connector body will not corrode, maintaining long term conductivity and pressure

A pressure connection that uses an ABYC compliant connector block provides a superior connection in situations where either very small wires are being used or where high quality ratcheting wire crimpers are not available.

Terminal Feed Through Connectors

Perfect for passing high current through hulls, decks and bulkheads. Large cables passed through holes are subject to chafing even when protective grommeting is used. Terminal Feed Through Connectors eliminate chafing and provide excellent strain relief for the cables. The large terminals have a mounting face that can be gasketed or bedded to provide a water tight installation.

Specifications

Voltage Rating 48 Volts DC Maximum
 Base Material Reinforced Thermoplastic
 Stud Material Tin-Plated Copper Alloy

PN	Size	Description	Continuous Amperage	Color	Weight Lb (Kg)
2201	Small	5/16"-18 Stud	250A	Black	0.23 (0.10)
2202	Small	5/16"-18 Stud	250A	Red	0.23 (0.10)
2203	Small	3/8"-16 Stud	250A	Black	0.23 (0.10)
2204	Small	3/8"-16 Stud	250A	Red	0.23 (0.10)
2205	Large	3/8"-16 Stud	400A	Black	0.69 (0.31)
2206	Large	3/8"-16 Stud	400A	Red	0.69 (0.31)
2207	Large	1/2"-13 Stud	400A	Black	0.69 (0.31)
2208	Large	1/2"-13 Stud	400A	Red	0.69 (0.31)



2201



2202



2207



2208

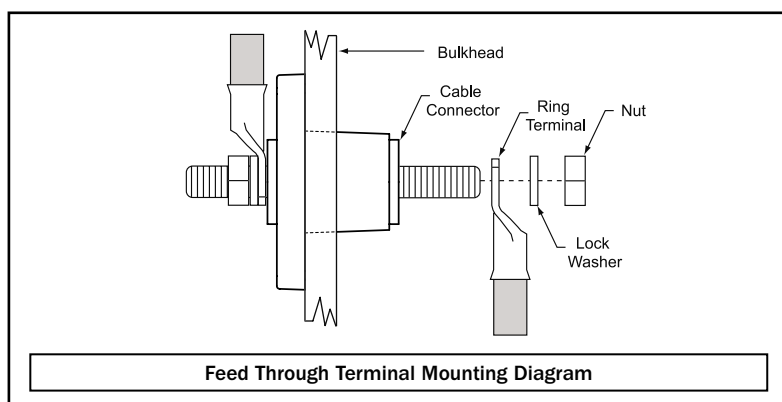
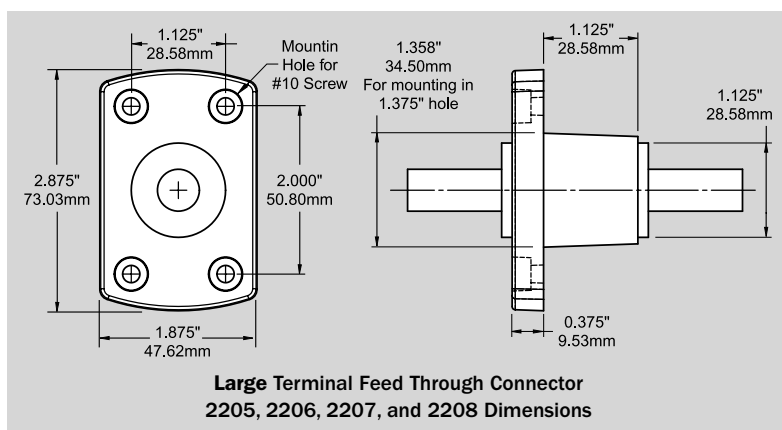
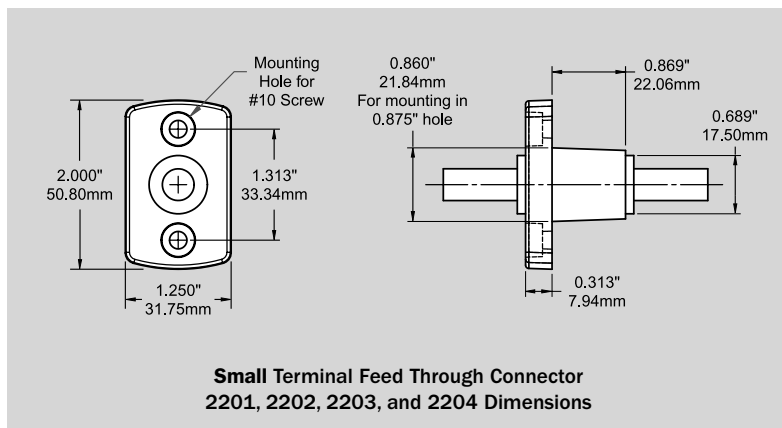

CONNECTORS

PowerPost High Amperage Cable Connectors

- Connects high amperage cables securely

Specifications

Continuous Amperage Not rated - Amperage flows between terminals stacked on post and is determined by wire and terminals used.

Voltage Rating 48 Volts DC Maximum

Base Material Reinforced Thermoplastic

C E marked



2010



2003

PN	Size	Description	Weight Lb (Kg)
2010	Small	#10-32 x 5/8" stud	0.06 (0.03)
2011	Small	1/4" x 3/4" Stud	0.08 (0.04)
2001	Large	1/4" x 1-1/16" Stud	0.21 (0.10)
2002	Large	5/16" x 7/8" Stud	0.23 (0.11)
2003	Large	3/8" x 7/8" Stud	0.27 (0.12)

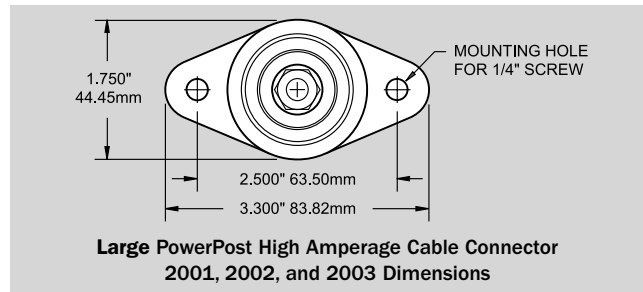
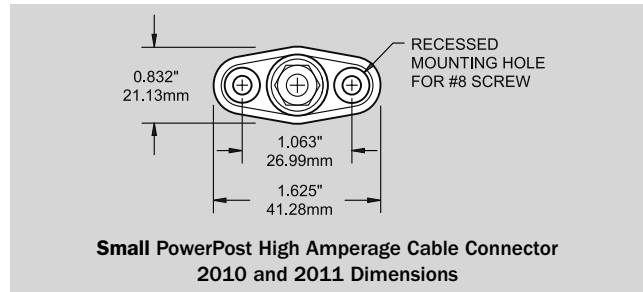

PowerPost Plus Cable Connectors

- 150 Ampere bus allows small wire connections at high amperage cable connections

Specifications

Bus Continuous Amperage 150 Amperes AC/DC

Voltage Rating 48 Volts DC Maximum

Bus Material Tin-Plated Copper

Base Material Reinforced Thermoplastic

C E marked



2103

PN	Description	Weight Lb (Kg)
2101	1/4" x 1" Stud	0.29 (0.13)
2102	5/16" x 3/4" Stud	0.30 (0.14)
2103	3/8" x 3/4" Stud	0.34 (0.15)

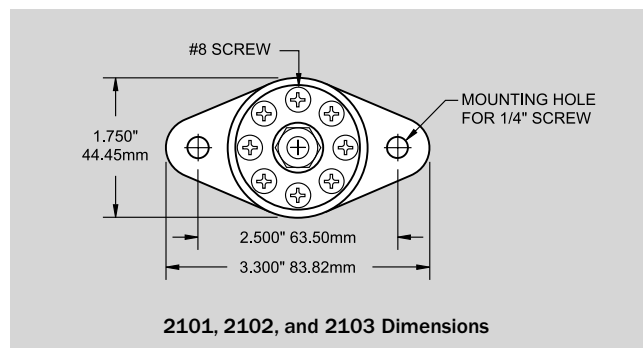

CONNECTORS

CableClams

- Perfect for antenna installation
- Waterproof co-axial installation without removing connectors
- Save the expense of removing and replacing connectors
- Avoid poor connections from removing factory connectors

Specifications

Body Material Acetal
 Seal Material UV-Stabilized Buna-N Rubber
 Screws Stainless Steel

PN	Connector Opening in" (mm)	Weight Lb (Kg)
1001	0.63 (15.87)	0.15 (0.07)
1002	0.83 (20.95)	0.19 (0.09)
1003	1.39 (35.18)	0.22 (0.10)



1001-1003

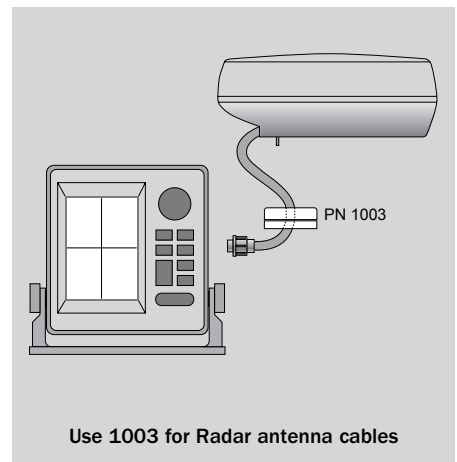
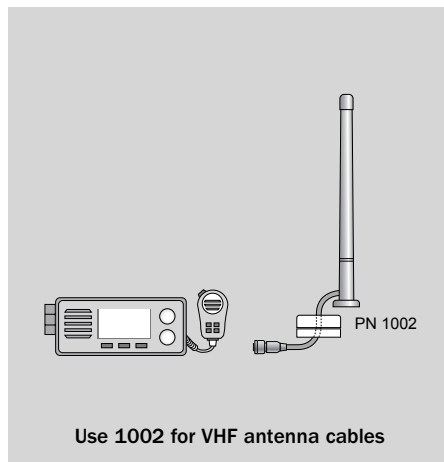
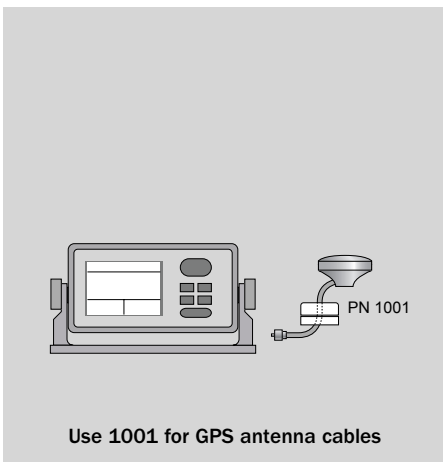
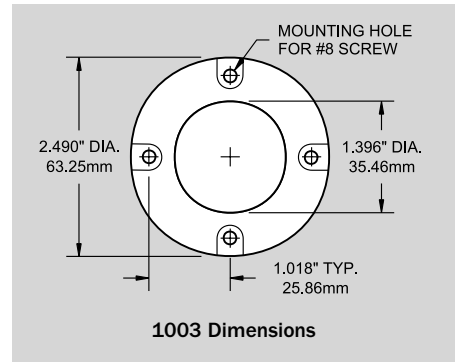
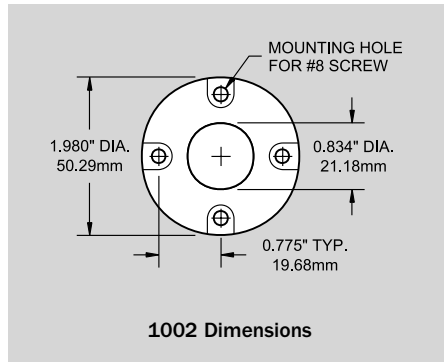
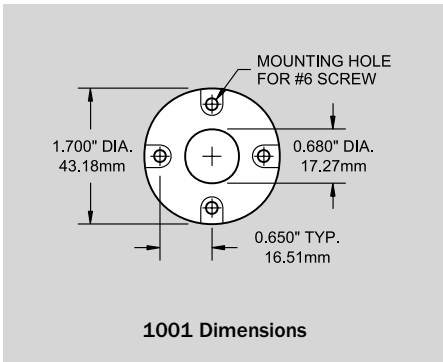
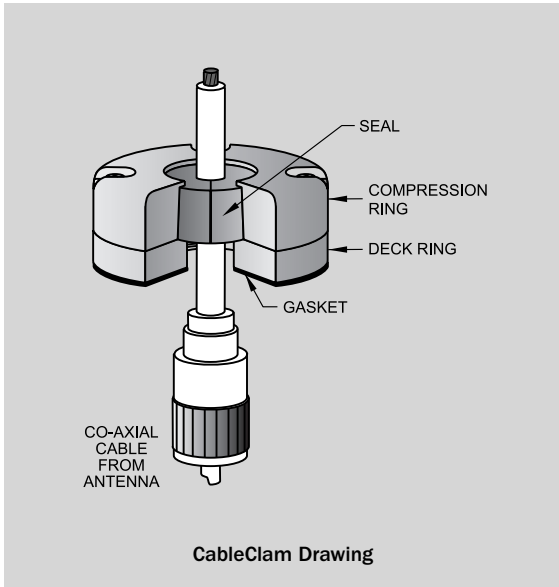

INSULATION AND SAFETY



4001

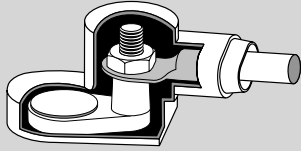

Rotating CableCaps

- Top rotates 360 degrees to allow cable entry from any angle
- For batteries with integral marine wing nut posts

Specifications

Material PVC

PN	Cable Size	Color	Package	Weight Lb (Kg)
4001	All	Red/Black	Retail/Pair	0.24 (0.11)
9030	All	Black	Bulk	0.10 (0.45)
9031	All	Red	Bulk	0.10 (0.45)



4005

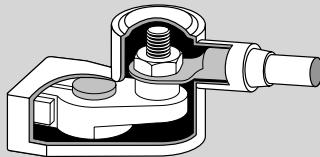

Standard CableCaps

- For batteries with marine adaptor terminals added on

Specifications

Material PVC

PN	Cable Size	Color	Package	Weight Lb (Kg)
4005	4, 2, 1	Red/Black	Retail/Pair	0.17 (0.08)
4006	1/0, 2/0	Red/Black	Retail/Pair	0.17 (0.08)
9038	4, 2, 1	Black	Bulk	0.07 (0.03)
9039	4, 2, 1	Red	Bulk	0.07 (0.03)
9040	1/0, 2/0	Black	Bulk	0.07 (0.03)
9041	1/0, 2/0	Red	Bulk	0.07 (0.03)



4016

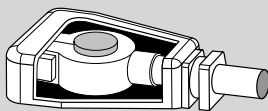

Automotive CableCaps

- Designed to fit standard automotive posts

Specifications

Material PVC

PN	Cable Size	Color	Package	Weight Lb (Kg)
4016	4, 2, 1	Red/Black	Retail	0.15 (0.07)
4017	1/0, 2/0	Red/Black	Retail	0.15 (0.07)
9174	4, 2, 1	Black	Bulk	0.07 (0.03)
9175	4, 2, 1	Red	Bulk	0.07 (0.03)
9176	1/0, 2/0	Red	Bulk	0.07 (0.03)
9177	1/0, 2/0	Black	Bulk	0.07 (0.03)



4009

4008

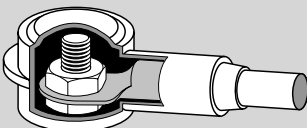

CableCap Stud Insulators

- Insulate stud type connectors on alternators, starters, windlasses and other high amperage devices

Specifications

Material PVC

PN	Cable Size	Color	Package	Weight Lb (Kg)
4008	18-10	Red	Retail/3	0.05 (0.02)
4009	18-10	Black	Retail/3	0.05 (0.02)
4010	8-4	Red	Retail/2	0.05 (0.02)
4011	8-4	Black	Retail/2	0.05 (0.02)
4012	2-2/0	Red	Retail/1	0.07 (0.03)
4013	2-2/0	Black	Retail/1	0.07 (0.03)
4014	3/0-4/0	Red	Retail/1	0.07 (0.03)
4015	3/0-4/0	Black	Retail/1	0.07 (0.03)

Battery Boxes

The most advanced design available for Golf Cart, 4-D and 8-D batteries.

- Direct restraint system - the easiest installation of any box
- Straight cable entry path - no awkward bending of heavy cables
- Electrolyte reservoir - the battery is held away from spilled electrolyte
- Captive lid hold-down system - no more lost nuts in the bilge
- When installed according to instructions this battery box satisfies the following:
 - United States Coast Guard Code of Federal Regulations Title 33, Subpart I, Part 183.420
 - American Boat and Yacht Council (ABYC) Standards and Recommended Practices for small craft section E-10.7

Specifications

Material UV Stabilized Polyethylene



Winner Industrial Design Excellence Award

PN	Description	Weight Lb (Kg)
4021	Twin Golf Cart	10.70 (4.86)
4022	4D	12.50 (5.68)
4023	8D	13.90 (6.32)



4021



4022



4023

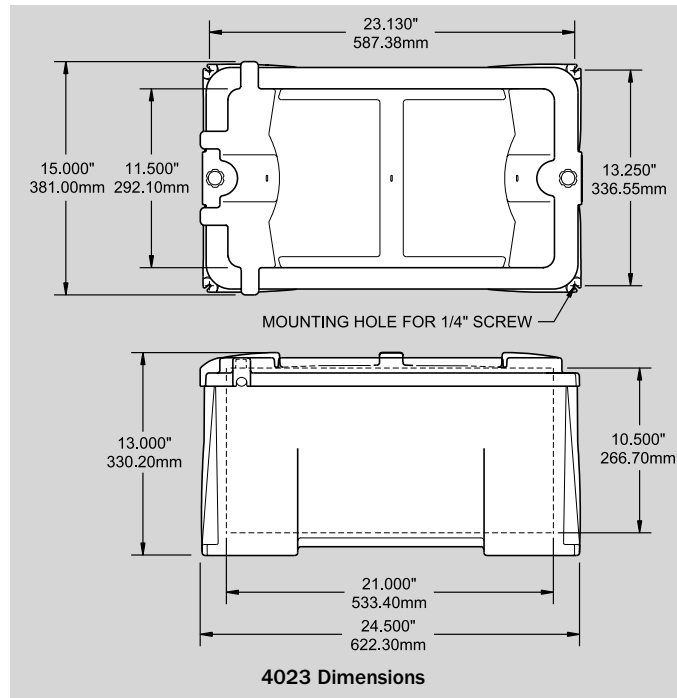
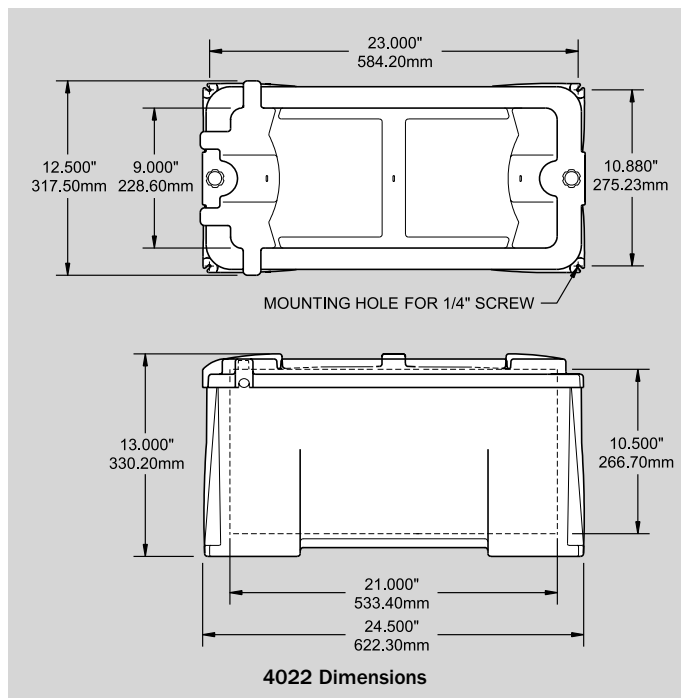
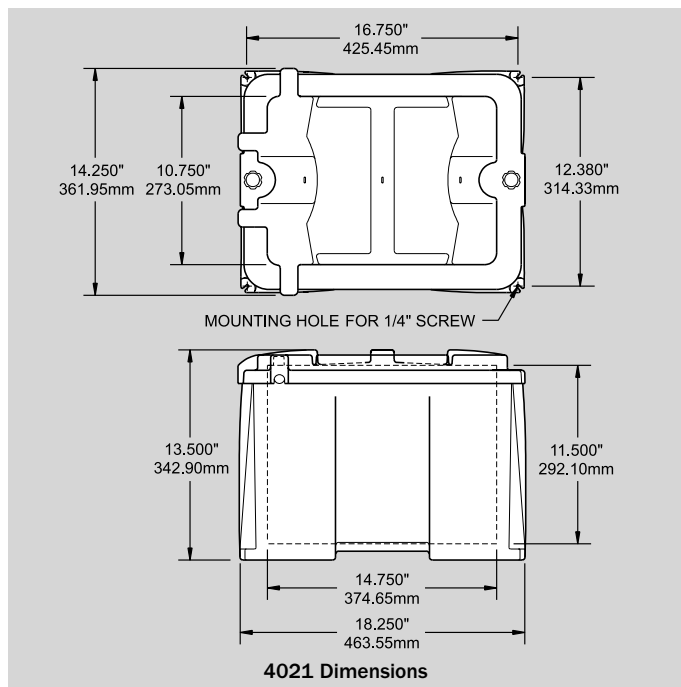

NUMERIC

120V AC

The line to neutral voltage in a single-phase two wire AC, not including green safety ground, system as commonly found in the US.

240V AC

The line to line voltage in a single-phase three wire (not including green safety ground) AC system as commonly found in the US.

230V AC

The line to neutral voltage in a single-phase two wire (not including green safety ground) AC system as commonly found in Europe and many other parts of the world.

3 phase *see also Single Phase*

Refers to 3 phase power generation typically 480V AC and higher. The AC utility is a three-phase system. In its simplest form there are three conductors connected to three conductive coils, which pass through a magnetic field, thus, inducing the electrons in the wires to flow. As the polarity of the magnetic field changes from North to South, electrons are induced to flow first one way then the other. This produces AC current flow. The current that is induced in the three wires is 120° out of phase. The current flow in the first conductor starts 120° before the second and it starts 120° before the third. Three phase generators are only found on the largest boats.

3 stage charging

A technique of battery charging that uses three distinct stages to ensure a fast and complete charge and a safe maintenance voltage. As there are several manufacturers of multiple stage charging systems, there is a slight difference in terminology in the field. See each key word for a more complete definition.

- Stage 1: Charge or Bulk Mode
- Stage 2: Acceptance or Absorption
- Stage 3: Float

A

ABYC

American Boat and Yacht Council, a voluntary standards creating body for the marine industry responsible for Standards and Recommended Practices.

AC

see Alternating Current

AFD

see Alternator Field Disconnect

AGC Fuse

A 1-1/4 inch long x 1/4 inch diameter glass fuse with fast blow characteristics.

AIC Amperes Interrupt Capacity

see Interrupt Rating

ATO/ATC Fuse

The blade type fuse now commonly used in the automobile industry. It has fast blow characteristics like the AGC fuse.

AWG (American Wire Gauge)

see also SAE Wire Gauge

AWG (American Wire Gauge) is a U.S. standard set of non-ferrous (copper or aluminum) wire conductor sizes. The "gauge" refers to the diameter. Typical household wiring is AWG number 12 or 14. Telephone wire is usually 22, 24, or 26. The higher the gauge number, the smaller the diameter and the thinner the wire. Thicker wire can carry more current because it has less electrical resistance over a given length. Also larger wire is used when the voltage drop along its length must be minimized. For example: High output alternator wiring might be a 2 AWG while the starter cable for a modest engine a 1 or 0 AWG.

absorption *see 3 Stage Charging*

see also Float Charge, Bulk, Equalization

Absorption refers to the second phase of a multistage charging system, also called acceptance by some manufacturers. During the absorption cycle the battery is maintained at the maximum charging voltage. Typically about 2.4V per cell or 14.4V for a typical 12V system. (28.8V for a 24V system). This is the gassing voltage for a liquid battery. Gelled batteries are typically charged at slightly lower voltages. The gassing voltage is also temperature dependent. The battery cannot be maintained for long periods of time in the absorption phase.

acceptance

see absorption

alternating current

A periodic current (sine wave) with an average value over a cycle of zero. The current reverses at regular intervals of time and has alternately positive and negative values.

alternator

Commonly refers to the DC charging source on an engine. The alternator is a three-phase AC device that produces alternating current, which is then rectified by a diode bridge to create direct current. Three-phase AC devices are reliable and inexpensive to make compared to a DC generator of the same ampacity.

alternator field disconnect

The alternator field is created by a coil of wire surrounded by ferrous metals. When the coil is energized with electric current it becomes an electro-magnet. This electromagnet is rotated, inducing current flow in the three phase coils that surround it. By controlling the strength of the magnetic field, the output of the alternator may be controlled. If the output of the alternator is open circuited there is no place for the energy to go. The voltage rises to a dangerous level. By disconnecting the alternator field, the magnetic field is turned off, thus the voltage cannot soar. This is a safety feature on some battery switches.

ambient temperature

The temperature of the medium in which the heat of a device is dissipated. The ambient temperature is often specified in standards for device performance (such as the UL Standards) as the basis for determining the heat rise of the component.

ammeter

Ammeter measures current flow in a circuit. An ammeter is inserted in series in the circuit. We consider four types:

Analog

The classic analog ammeter uses the magnetic field associated with current flow through a moving coil of wire, to in turn move a needle over a meter face which displays amps. This type of meter can only measure very small current, micro-amps, before the moving coil becomes too large to be practical. To measure higher currents a shunt resistor is inserted into the circuit. (see Shunt). Most of the current flows through the shunt resistor but some passes through a meter movement as described to read amps when the movement is scaled appropriately.

Digital DC

The digital DC ammeter uses a shunt resistor to measure current flow. (see Shunt). The shunt is connected in series in the wiring of the circuit whose current is to be measured. The shunt sense leads are connected to the DC ammeter, which is really a millivolt meter. The millivolt input from the shunt is scaled to read amps per the resistance of the shunt. For example, a current flow of 10 amps through a 100A-100mV shunt would result in a voltage of 10mV across the sense leads. A millivolt meter would display 10, which we would interpret as 10 Amps.

Digital AC

The digital AC ammeter also uses a shunt resistor to measure a voltage drop, which is then scaled to read amps. The difference, however, is that the resistor is not normally connected directly in the AC wire of the circuit to be measured. A device called a current transformer (CT, see Current Transformer) is placed around the AC wire. A current is induced in the CT, which is then passed through a load resistor. The digital meter actually measures the voltage across this load resistor and internally scales it to read the appropriate number of amps.

Portable

Most portable meters today are digital and use the same techniques of measurement as described above. However, they are commonly limited to a few amps when connected in series to measure current. If high currents are to be measured, the portable meter must use some external sensing means. Commonly these consist of shunt resistors and clamp-on ammeter sensors that use Hall Effect sensors. (Operation of which are beyond the scope of this appendix. In short, they generate a voltage, which can be scaled to read amps just as the shunt resistor.)

ampacity

The current carrying capacity of a conductor or device.

ampere *see Coulomb*

Definition 1

The classic definition of an ampere is a unit of electric current flow equivalent to the motion of 1 coulomb of charge, or 6.25 X 10¹⁸ electrons, past any cross section in 1 second. This is an intuitive way to think about an ampere. It is the flow of a huge number of electrons through a conductor.

Definition 2

In 1948 this alternative definition was adopted: A unit of electric current in the meter-kilogram-second system. It is the steady current that when flowing in straight parallel wires of infinite length and negligible cross section, separated by a distance of one meter in free space, produces a force between the wires of 2 x 10⁻⁷ newtons per meter of length.

ampere-hour

The electric charge transferred past a specified circuit point by a current of one ampere in one hour.

Amp-Hour Rating (AH)

This is a common rating for batteries. This is the total number of ampere-hours that a battery can deliver over 20 hours at a constant rate of discharge before the battery voltage falls below 10.5 volts.

analog

Refers to a signal or input that varies continuously over time. Voltages and currents are analog signals, as are temperature and pressure.

anode

The electrode of an electrochemical cell with the more negative potential. The less noble metal of an electrolytic cell that tends to corrode.

B

battery *see also Cell*

Two or more cells connected together. Thus a group of batteries connected together can also be referred to as a battery.

battery bank

When groups of batteries are wired in series or parallel or a combination to increase voltage or capacity the entire group is referred to as a battery bank. When batteries are connected in series the amp-hour rating is the same and the voltage is additive. When batteries are connected in parallel the voltage is the same and the amp-hour rating is additive.

battery state-of-charge

The term is used to describe and estimate of how much energy the battery is able to deliver. There have been many attempts to develop improved state-of-charge estimates. The most common methods include: specific gravity, at-rest open-circuit voltage, and amp-hour measurement.

battery switch rating

see *Continuous Switch Rating and Intermittent Switch Rating*

battery types

AGM (Absorbed Glass Mat)

A technique for sealed lead-acid batteries. The electrolyte is absorbed in a matrix of glass fibers, which holds the electrolyte next to the plate, and immobilizes it, preventing spills. AGM batteries tend to have good power characteristics, low internal resistance, and good behavior during charging.

Flooded

A design for lead-acid batteries. The electrolyte is an ordinary liquid solution of sulfuric acid. Flooded cells are prone to making gas while being charged. Flooded cells must be periodically checked for fluid level and water added as necessary. Flooded cells are also typically less expensive than AGM or gel cell type lead-acid batteries.

Gel cell

Gel or sealed lead acid batteries are basically the same chemistry as a wet (flooded cell) battery. The batteries' electrolyte is in a gelatin form and is absorbed into the plates and the battery is sealed with epoxies. The batteries are exceptionally leak resistant and may be used in any position. Battery uses include UPS, emergency lights, and camcorders. These batteries are 2 volts per cell, so the common batteries are 4, 6, and 12 volt.

blade

That portion of a fuse to which the fuse block connects.

bonding, cathodic

The electrical interconnection of metal objects in common contact with water, to the engine negative terminal, or its bus, and to the source of cathodic protection.

branch circuit see also *Main*

The portion of the wiring system after the main circuit protection device.

break (rating)

The amount of current that can be passing through a set of contacts, such as those in a solenoid, when they open, without damaging the contacts. This can be a rating for a single event or over some number of cycles, generally 1000, 10,000 or 1,000,000.

bulk

That part of a multi-stage charge regime at which the maximum amount of current is flowing. This is normally limited by the size of the charging source. Lead acid batteries have the ability to accept, or absorb, large charging currents as long as they do not overheat or begin gassing. The bulk cycle allows the fastest possible charge.

bus, busbar

A bus is a group of common connections, often consisting of a strip of copper or brass with a number of screws or bolt studs for the connection of wires. It may be a negative or a positive bus.

C

CE (Conformité Européenné)

The CE marking is a conformity marking consisting of the letters "CE". The CE marking is applied to products regulated by certain European health, safety and environmental protection legislation. The CE marking is obligatory for products it applies to. The manufacturer affixes the marking certifying that the product conforms to applicable regulations, in order to be allowed to sell the product in the European market.

CFR (Code of Federal Regulations)

The written regulations of the United States Federal Government.

cathode

The electrode of an electrochemical cell with the more positive potential. The more noble metal of an electrolytic cell that tends not to corrode.

cell

An electrochemical system that converts chemical energy into electrical energy. Typically consisting of two conductive plates with different galvanic potential immersed in an electrolyte.

cell, primary

An electrochemical device, which is discharged only once and then, discarded.

cell, secondary

see also *Battery*
An electrochemical device, which may be discharged and recharged a number of times.

charge

Classically refers to an accumulation of electrons producing an electrostatic charge. In common use it often refers to restoring energy to a battery. Specifically, it would refer to the part of a multi-stage battery charging cycle when the voltage was held constant at or about the gassing voltage.

charge cycle

The stages through which a multi-stage charging source restores energy to a battery. A four-stage charge cycle includes:

bulk or charge cycle

Constant current for fast charging

acceptance or absorption cycle

Constant voltage for thorough charging

float cycle

For maintenance and long life

equalization cycle

Controlled overcharge for maximum capacity.
see *key words above*

circuit

A closed path of electrically, or electro-magnetically connected, components or devices that is capable of current flow. Typically consisting of loads, sources, conductors, and circuit protection (circuit breakers and fuses). For example: A battery, fuse, and bilge pump connected together with wire are a circuit. The path must be continuous and closed.

circuit breaker

A device that, like a fuse, interrupts current in an electric circuit when the current becomes too high. Unlike a fuse, a circuit breaker can be reset after it has tripped. When high current passes through the circuit breaker, the heat it generates or the magnetic field it creates causes a trigger to rapidly separate the pair of contacts that normally conduct the current.

Circular mils

A method of specifying wire size mathematically. One Circular Mil is a unit of area equal to that of a circle .001" in diameter. The actual area of a Circular Mil is:

$$A = \pi r^2$$

$$A = 3.1428 \times (.0005)^2 \text{ inches}$$

$$A = .0000007857 \text{ square inches}$$

Class-T fuse

A very robust fuse with a 20,000 AIC. It also has very fast response to short circuit currents.

coil

see *inductor*

Cold Cranking Amperes (CCA)

see also *Marine Cranking Amperes*
CCA is the discharge load in amps which a battery can sustain for 30 seconds at 0° F. (-18° C) and not fall below 1.2 volts per cell (7.2V on 12V battery). This battery rating measures a burst of energy that an engine needs to start in a cold environment. This

rating is used mainly for rating batteries for engine starting capacity and does not apply to NiCad batteries, NiMH batteries or Alkaline batteries.

common

May have more than one meaning. Typically denotes a bus that is at ground potential most often. The negative bus is called "the common"; sometimes the neutral bus is also called "the common". May also mean a group of connections that are connected together "in common" even though they are at a different potential than ground.

conductivity

Conductance is the reciprocal of resistance, which depends on the resistivity constant of the material. Resistivity is the resistance of a conductor having unit cross section and unit length. Conductivity is the reciprocal of the resistivity. Its units are 1/ohm-cm or ohm/cm, or 1/ohm-circular mils/ft.

conductor

That part of an electrical circuit whose resistance relative to the balance of the circuit is zero. For example, in a circuit consisting of a light bulb and a battery, connected together with wire, the wire is referred to as the conductor.

Conformité Européenné

see *CE*

continuous current

The current flow, which a device or a conductor can carry, consume, or supply with no time limit. The continuous current rating is normally dependent on the temperature, since resistance increases with temperature. For battery switches the continuous current rating is established by testing for one hour at the rating. This is reasonable since thermal equilibrium would be reached within one hour.

continuous switch rating (UL 1107)

The two ratings in the UL marine battery switch standard are Intermittent and Continuous. Intermittent is a 5 minute rating and is based on temperature rise of various sections of the switch as the rated current is applied over a 5 minute period. The Continuous rating is the same, but the time period is 1 hour.

converter

An electrical device that converts one type of electrical energy into another. Battery chargers convert AC power to DC to charge the battery. Inverters convert DC power into AC, both are converters. Often used in RV industry to mean a power supply that runs the domestic DC loads when shore power is available.

coulomb see also *Ampere*

The measurement unit of electric charge, which is determined by the number of electrons in excess (or less than) the number of protons. Classically a charge of 1 coulomb = 6.25 X 10¹⁸ electrons. The meter-kilogram-second unit of electrical charge equal to the quantity of charge transferred in one second by a steady current of one ampere.

counterpoise

That portion of an antenna system composed of wires or other types of conductor arranged in a circular pattern at the base of the antenna at a certain distance above ground. Insulated from the ground, it forms the lower system of antenna conductors.

cranking (starting)

Normally associated with "cranking current" which is the current required by the starter circuit prior to engine starting. The cranking current varies significantly during the starting cycle. Initially, there is a large surge of current required to overcome the inertia and compression of the engine. This surge can be two to four times the average cranking current. Once the engine is turning there are peaks and valleys as the pistons go through the compression and exhaust cycles. The cranking current rating is used for sizing batteries, cables, and battery switches.

current *see also Amperage*

Current is a flow of electrical charge carriers, usually electrons or electron-deficient atoms. The common symbol for current is the uppercase letter I. The standard unit is the ampere, symbolized by A. Physicists consider current to flow from relatively positive points to relatively negative points; this is called conventional current or Franklin current. Electrons, the most common charge carriers, are negatively charged. They flow from relatively negative points to relatively positive points.

Electric current can be either direct or alternating. Direct current (DC) flows in the same direction at all points in time, although the instantaneous magnitude of the current might vary. In an alternating current (AC), the flow of charge carriers reverses direction periodically. The number of complete AC cycles per second is the frequency, which is measured in Hertz. An example of pure DC is the current produced by an electrochemical cell. The output of a power-supply rectifier, prior to filtering, is an example of pulsating DC. The output of common utility outlets is AC.

current rating

The maximum current in amperes that a device will carry continuously under defined conditions without exceeding specified performance limits.

current transformer *see also Ammeter*

The "CT", as current transformers are commonly referred to, is used by AC ammeters to "sense" current flow in a wire in an AC circuit. It is a toroidal coil of wire through which a wire whose current we wish to measure is passed. It is normally encapsulated and looks like a "doughnut", which is how electricians commonly refer to it. The doughnut has two wires coming out of it, which are connected to the AC ammeter. As current flows in the AC wire we wish to measure, it induces a current flow in the current transformer. The magnitude of the current varies directly with the current flowing in the AC wire. Current transformers are rated by the number of maximum amps that can flow in the measured wire and the current generated, by the CT, at that current flow. For example: A 50:5 CT is rated for 50 amps flowing in the measured wire, and it generates 5 amps of current as a consequence.

cycle

A cycle of a battery is a discharge plus a charge. For example, if a fully charged battery has a load applied, is then discharged and recharged, that is one cycle. Cycle life is the total number of cycles a battery yields.

D

DC *see Direct Current*

deep-cycle batteries

Batteries with thick plates to allow for reserve energy to be stored within the battery plate and released during slow discharge for prolonged periods. The high-density active material remains within the batteries' plate/grid structure longer, resisting the normal degradation found in cycling conditions. Deep cycle batteries are typically used where the battery is discharged to a great extent and then recharged.

delay

A difference in time between the initiation of an event and its occurrence, or between an event's observation and enunciation of it. This is usually used to refer to the time between the application of current through to a fuse or circuit breaker and the time when the device opens.

derating

A decrease in a device's rating, usually amperage, due to its application in ambient conditions different from those in which it was tested or for which it was designed originally.

dielectric strength

The maximum voltage that a material can withstand without allowing the two voltage potentials to short together.

Specifications subject to change. See www.blueseas.com for current information.

digital

A digital signal is one which has only two valid values denoted as 1 or 0. Commonly these are equated to distinctly different voltage. For example: A voltage of +5V would equal a 1 and a voltage of 0V would equal a 0.

A digital meter is one that displays values as numerical values rather than as the position of a meter on a relative scale.

Direct Current (DC)

An electric current that always flows in the same direction. The magnitude may vary but the current direction is always the same. Commonly referred to as DC. Examples of direct current sources are batteries, fuel cells, and photovoltaic cells. DC sources such as battery chargers and alternators actually use rectified AC current as the source.

discharge

Refers to the consumption of energy from a battery, or to the electrostatic discharge associated with a lightning bolt, capacitor, etc.

double insulation system

An insulation system comprised of basic insulation and supplementary insulation, with the two insulations physically separated and arranged so they are not simultaneously subjected to the same deteriorating influences to the same degree.

double pole

Indicates a switch, relay, or circuit breaker with two separate conductive paths, which are opened or closed simultaneously when the device is operated.

E

Earth

The third planet from the sun in Astronomy, but in electrical terms it refers to a connection, which is made to a conductor that is connected to the planet Earth. In grounded electrical systems there is a connection, which is a copper rod or some other highly electrically conductive connection, to the actual Earth. This is to ensure a safe conductive path for a short circuit, which in turn helps prevent electrocution.

electrode

A conductive material, in an electrolyte, through which electrical current enters or leaves.

electrolysis

Chemical changes in a solution, or electrolyte, due to the passage of electric current.

electrolyte

A liquid in which ions are capable of migrating and, therefore capable of conducting current. Solutions of acids, bases, and salts in water are electrolytes.

electron *see also Coulomb*

An electron is a negatively charged subatomic particle. It can be either free (not attached to any atom), or bound to the nucleus of an atom. In electrical conductors, current flow results from the movement of free electrons from atom to atom individually, and from negative to positive electric poles in general.

The charge on a single electron is considered as the unit electrical charge. It is assigned negative polarity. Electrical charge quantity is not usually measured in terms of the charge on a single electron, because this is an extremely small charge. Instead, the standard unit of electrical charge quantity is the coulomb, symbolized by C, representing about 6.25×10^{18} electrons.

Electromotive Force (EMF)

Commonly referred to as voltage, electromotive force is the energy per unit of charge that is supplied by a source of electrical energy such as a battery, charger or alternator.

Electromagnetic Interference (EMI)

Noise generated by a load (typically by electrical switching action). Usually specified as meeting agency limits for conducted EMI (noise conducted back onto the power bus) or radiated EMI (noise emitted into the area surrounding a device).

energy *see also Power*

The classically simple definition is, the capacity to do work. Energy may be manifested as, mechanical motion, thermal heat, or electrical power, which is consumed, radiated, dissipated, or stored over a period of time. The energy in a direct-current circuit is equal to the product of the voltage in volts, the current in amperes, and the time in seconds. The units for energy are Watt-hours. In alternating current (AC) circuits, the expression for energy is more complex.

engine negative terminal

The point at which the engine negative, generally the engine block, is connected to the negative of the battery.

equalization *see Charge Cycle*

Equalization is a controlled overcharge, which removes lead-sulfate that is not converted during normal charging. Equalization is best accomplished by using a constant current of 2-7% of battery capacity while allowing the battery voltage to rise to its highest "natural voltage". For a 12V battery this can be as high as 16.2V. The equalization cycle is continued until the specific gravity of all cells cease to continue to rise and are approximately equal. The equalization cycle should only be used on liquid electrolyte batteries and only while the operator is on the premises.

equalizer

A device wired across the same potential poles of a multiple bank battery bank consisting of serially wired batteries, i.e., two 12 volt batteries in series to produce 24 volts. An equalizer maintains half its input voltage at its output terminals. When loads are taken off one of the batteries in the bank at that batteries voltage, which is half of the bank voltage, the equalizer senses that battery's voltage is no longer the one half the voltage of the entire bank and the equalizer "recharges" the lower voltage battery from the higher voltage battery.

F

fast, fast acting *see also Delay*

Refers to the amount of time that a fuse can endure an over-current before blowing. Fast fuses are used to protect sensitive equipment.

fault

A defect in the normal circuit configuration, usually due to unintentional grounding. Commonly referred to as a short circuit.

field

Typically refers to a magnetic field. Specifically used when discussing the rotating electro-magnetic field associated with an alternator. By varying the field current, thus its strength, the output of the alternator may be controlled.

float charge

see also Bulk, Acceptance, Equalization

A constant voltage, well below the gassing point, that is applied to a battery to maintain its capacity. The voltage is such that neither charging nor discharging is occurring.

frequency *see also Hertz*

For an oscillating or varying current, frequency is the number of complete cycles per second in alternating current direction. The standard unit of frequency is the hertz, abbreviated Hz. If a current completes one cycle per second, then the frequency is 1 Hz; 60 cycles per second equals 60 Hz (the standard alternating-current utility frequency).

fuse

A fuse is a safety device, consisting of a strip of low-melting-point alloy, which is inserted in an electric circuit to prevent excess current from flowing. If the current becomes too high the alloy strip melts, opening the circuit.

fusible link

A type of fuse with a replaceable conductive alloy link that may be replaced if it “blows” due to over-current.

G

galvanic corrosion

The corrosion that occurs at the anode(s) of a galvanic cell.

galvanic isolator

A device installed in series with the (AC) grounding (green) conductor of the shore-power cable to effectively block low voltage DC galvanic current flow, but permit the passage of alternating current (AC) normally associated with the (AC) grounding (green) conductor. This is typically two diodes wired in parallel facing opposite directions, sized to meet full fault current.

galvanic compatibility chart

A list of metals and alloys arranged in order of their potentials as measured in relation to a reference electrode when immersed in seawater. The table of potentials is arranged with the anodic or least noble metals at one end, and the cathodic or most noble metals at the other.

generator

A rotating machine capable of generating electrical power. In the narrow definition generator refers to a DC machine and alternator refers to an AC machine. However, in common use the term generator is used to refer to AC machines as well.

green wire

The green wire is the non-current carrying safety grounding wire in an AC system in the United States. It is connected to an exposed metal part in the electrical system to provide a path for fault current in the case of a short circuit.

ground fault

GFI (Ground Fault Interrupter)

GFI is a generic term referring to both GFCI and GFP

GFCI (Ground Fault Circuit Interrupter) see GFI

A device intended for the protection of personnel that functions to de-energize a circuit, or portion thereof, within an established period of time when a current to ground exceeds some predetermined value that is less than that required to operate the overcurrent protective device of the supply circuit.

GFP (Ground Fault Protector) see GFI

A device intended to protect equipment by interrupting the electric current to the load when a fault current to ground exceeds some predetermined value that is less than that required to operate the overcurrent protection device of that supply circuit.

ground, ground conductor

A point in a circuit which is at zero potential with respect to the Earth, or which is at the lowest potential in the system, (as with a floating ground).

grounded

The AC current carrying conductor that is intentionally maintained at ground potential, also called neutral.

grounding, grounding conductor

The AC conductor, not normally carrying current, used to connect the metallic non-current carrying parts of electrical equipment to the AC system and engine negative terminal, or its bus, and to the shore AC grounding conductor through the shore power cable. This term can also refer to the normally non-current carrying conductor used to connect metallic non-current carrying parts of direct current devices to the engine negative terminal, or its bus, to minimize stray current corrosion.

ground plate

A conductive plate, commonly sintered copper, that is placed in contact with seawater to provide a connection to earth for a boat’s ground systems.

H

Hertz *see Frequency*

Hertz is a unit of frequency of one cycle per second. It replaces the earlier term of “cycle per second (cps).” The abbreviation for Hertz is Hz.

hot

Hot usually refers to the ungrounded current carrying conductors in an AC system. These would typically have a voltage of 120V or 240V in the United States. The term Hot is also used to describe a circuit that is energized, and has a potential greater than ground.

I

IACS

see International Annealed Copper Standard

Impressed current

Direct current supplied by a device employing a power source external to the electrode system of a cathodic protection installation. The impressed current is used to counteract the undesired galvanic current.

inductance

An effect in electrical systems in which electrical currents store energy temporarily in magnetic fields before that energy is returned to the circuit.

inductor *see Coil*

A length of wire that is wound around a core that is used as a storage element for a magnetic field in an electric circuit.

inrush

The momentary steep wave front of very high current exhibited by a load on initial application of power.

Intermittent switch rating (UL 1107)

The two ratings in the UL marine battery switch standard are Intermittent and Continuous. Intermittent is a 5 minute rating and is based on temperature rise of various sections of the switch as the rated current is applied over a 5 minute period. The Continuous rating is the same, but the time period is 1 hour.

International Annealed Copper Standard

Abbreviated as IACS, this is a measurement of relative electrical conductivity that uses copper as the standard of 100%. The expression “Brass 28 IACS” would mean that the brass under discussion had 28% of the electrical conductivity of an identically sized piece of copper.

interrupt rating (AIC)

The fault current that a device, normally a fuse or circuit breaker, is capable of breaking without damage to the circuit.

inverter

An inverter converts DC power stored in a battery to AC power which is used by most household appliances.

Ignition protection (IP)

Devices, which operate in a potentially explosive environment, must be ignition protected. This would include engine rooms with gasoline engines. There is a very specific set of tests which a device must pass to claim ignition protection. They include operating safely in an explosive mixture of propane and air.

isolation transformer

A transformer that is inserted in series with the incoming AC power to provide a magnetic coupling for power between the ship’s systems and the AC grid. By magnetically coupling the power there is no direct connection by wires, which isolates the ships AC system from the AC grid.

isolator

Refers to two or more diodes wired in parallel and then inserted in series with the output of an alternator. This allows for the alternator to charge multiple batteries. The voltage drop across the diodes can cause incomplete charging. Isolators should not be used with alternators that use internal voltage sensing for regulation. To be properly installed the voltage sense lead must come from the house battery.

J, K

kilo

A prefix in the metric system equal to 1000 times, as in kilohertz, 1000 cycles per second.

L

line *see also Load*

The conductors that are at the supply of energy to a circuit. Line normally refers to the current carrying non-grounded conductors in an AC system.

line loss *see Voltage Drop*

The power loss that occurs due to amperage flowing through the resistance of conductors over their length.

listed (UL Listed)

Indicates that a device or component has met certain specifications as set forth by Underwriters Laboratory. Further, it means that the device or component has been tested for conformance and ‘listed’ with UL so it can use the UL logo and claim conformance to the specification.

load *see also Line*

A device that consumes power and does work.

load group

A collection of loads, which normally have similar characteristics. For example the lighting circuits might be considered a load group. Also implies that the loads are supplied by a common bus.

lockouts (AC)

A device allowing the selection of only one source from multiple AC sources, preventing the connection of more than one source of AC power to a bus at the same time.

M

magnetic

Displaying the characteristics of a magnet, including being able to induce current flow in a conductor when relative motion exists between them and being able to attract ferrous materials.

main *see also Branch Circuit*

Refers to the main circuit breaker or bus in a power distribution system. This is the input power source for the system.

make (rating)

The current that a breaker, switch, or relay can connect into without damaging the device.

make before break

Describes a switch action that connects the new circuit before disconnecting the old. This type of switch action is required for battery selector switches in order to avoid an open circuit for the engine alternator, which can cause extreme voltages that can damage the alternator and accessory electronics.

Marine Cranking Amperes (MCA)

MCA is the discharge load in amps, which a battery can sustain for 30 seconds at 32°F (0° C), and not fall below 1.2 volts per cell (7.2V on 12V battery). This battery rating measures a burst of energy that an engine needs to start in a cold environment.

modified sine wave

A marketing term to describe an AC waveform, created by an inverter that is a pulse width controlled square wave. While an improvement on the classic square wave inverter, it is not actually a sine wave or a close approximation.

motor circuit protection

Motors require circuit breakers or fuses that are specifically designed for their current requirements. This is because motors require a high initial surge of current to get them started.

N

NEC see *National Electrical Code*

NEMA

National Electrical Manufacturers Association

N-type (alternator)

An N-type alternator has a set of diodes, called the diode trio, which supply the positive DC potential required for the rotating field current. The actual regulator switches the negative to achieve the proper field strength to create the desired correct alternator output.

National Electrical Code NEC

The NEC is developed and maintained by the National Fire Protection Association which describes how residential, commercial, and RV electrical systems must be installed. The NEC is adopted, sometimes with revision, by states that also adopt the Uniform Building Code. Electrical inspections required by most building permits follow the NEC. While not required aboard boats, the NEC is a valuable guide to safe electrical systems. The goal of the NEC is personal safety and fire prevention.

neutral see also *Single Phase*

The neutral is the grounded current carrying conductor in a single phase, four wire, 120/240V AC system.

neutral-to-ground bonding

Connecting the ground and the neutral together via an electrical conductor.

neutral-to-ground switching

In the US, inverter/charger installations that are used in marine applications must have neutral-to-ground switching. This guarantees that the neutral and the green wire are common after the green wire connection to neutral that is achieved through the shore power cord no longer exists after the cord is disconnected and shore AC is no longer serving as the boat's AC source. There must also be only a single ground point in the AC system. This prevents a voltage differential from developing between the boat's AC neutral and the shore or genset AC neutral, which may cause an electric shock or nuisance tripping of GFI's.

non-inverter loads

Non-inverter loads are heavy loads that are not appropriate to run from an inverter because the load on the batteries would be excessive or illogical. They include hot water heater, electric space heat, air conditioning, heavy pumping loads, etc. A battery charger that supplies the same battery as is being used by the inverter would also be a non-inverter load.

nuisance trip

A circuit breaker or fuse, which trips or blows without the circuit actually being overloaded. This may be due to weak breaker or a surge current which requires a slow tripping breaker or a slow blow fuse.

O

ohm

The unit for resistance equals $V/I = \text{volts/amps}$. The unit of resistance is the ohm, symbol Ω , the Greek letter Omega.

Ohm's law

States that the ratio of the EMF (Electromotive Force) applied to a closed circuit to the current in the circuit is a constant. That constant is the resistance of the circuit. It may be stated as $V = IR$ (or $E = IR$, using E as the abbreviation of EMF whose units are volts). The unit of resistance is the ohm.

open

Indicates a condition in an electric circuit in which there is a break in the conductive path. The break may be intentional such as an open switch or relay or it may be unintentional such as a broken wire or a blown fuse. In any case, the continuous conductive path required for an electric circuit is not available.

open circuit voltage

Generally, the voltage of a source when it is not connected to a load through an electrical circuit. Specifically, the voltage of a battery when it is not delivering or receiving power. A typical value for a liquid lead acid battery is 12.8V for a fully charged battery which has not been charged or used for 24 hours. Open circuit voltage is sometimes used as an indicator of the state-of-charge of a battery.

The table below gives typical open circuit voltages for both liquid and gelled electrolyte lead-acid batteries at various states-of-charge. These voltages should be considered approximations and may vary according to manufacturer and the specific gravity of the electrolyte the battery is initially filled with.

Typical Open Circuit Voltage After 24 Hours for Liquid and Gelled Electrolyte Batteries

Percent Charge	Liquid Electrolyte per cell voltage	Liquid Electrolyte Nominal 12V Battery	Gelled Electrolyte per cell voltage	Gelled Electrolyte Nominal 12V Battery
100%	2.10	12.60	2.175	13.05
80%	2.09	12.54	2.13	12.78
60%	2.07	12.42	2.08	12.48
40%	2.04	12.24	2.05	12.30
20%	1.98	11.80	2.02	12.12
0%	1.95	11.70	1.98	11.88

overcurrent

When the current in a circuit exceeds the rating of the devices or conductors in it. Fuses and circuit breakers protect from overcurrent by opening the circuit if such a condition exists and/or persists.

P

PE

see *Protective Earth*

P-type (alternator)

A P-type alternator is one which one end of the coil which supplies the rotating magnetic field is connected to the negative and the regulator controls the positive side of the coil to regulate the alternator output.

panelboard

A collection of circuit breakers, switches, and instrumentation installed into a panel which provides the central point for power distribution and monitoring for the electrical system. May also refer to a smaller panel which is located remotely from the main panel which is used to supply loads in the adjacent area. In the marine industry they are usually called "panels", or "circuit breaker panels", or "distribution panels".

parallel circuit

An electrical circuit in which the positive connections are all in common and the negative connections are all in common. The voltage of the system appears across each branch of the circuit. The current varies as required by each load or source.

parallel device

A switch, solenoid, relay, or solid state device which is used to connect multiple batteries or busses together.

paralleling switch

Typically refers to a battery switch that allows multiple batteries to be connected together for engine starting. Often used to connect the battery serving the domestic system to the engine starting circuit for emergencies.

percent of charge

An estimate of the remaining charge in a battery. Percent of charge is very difficult to determine accurately without sophisticated microprocessor based calculations.

Peukert's equation

A formula that shows how the available capacity of a lead-acid battery changes according to the rate of discharge. The capacity of a battery is expressed in Amp-Hours, but the simple formula of current times hours does not accurately represent the situation. Peukert found that the equation: $C = I^n T$ fits the observed behavior of batteries. "C" is the theoretical capacity of the battery, "I" is the current, "T" is time, and "n" is the Peukert number, a constant for the given battery. The equation captures the fact that at higher discharge current, there is less available energy in the battery.

pigtail

Wires which protrude from a device to connect it to the circuit. Often used in encapsulated products. Sometimes refers to a method of hooking up circuits in which a group of conductors are connected together and then one wire is connected to the circuit. This is done in order to simplify wiring.

plate (battery)

Flat, typically rectangular components that contain the active material, lead or lead compound, and a mechanical support structure called a grid, which also has an electrical function, carrying electrons to and from the active material. Plates are either positive or negative, depending on the active material they hold.

polarity

Refers to the electrical charge, which may be positive or negative. It also refers to the positive and negative terminals of a battery or load in a DC system. In AC systems it refers to the connections made to the hot and neutral. There is often a reverse polarity light that indicates if the neutral and hot are reversed.

polarized system

An electrical system in which the positive and negative or the hot and neutral must be connected in a particular way and cannot be switched. Sometimes there are mechanical preventions to insure the correct polarity. For example, in an AC plug the physical configuration of the plug and receptacle force a polarized connection.

pole

Indicates a conductive path in a switch or relay. Switches that are single pole have one conductive path, switches that are two pole have two conductive paths. Also refers to the magnetic poles on an electromagnet or a permanent magnet.

potential

The voltage across a circuit element. Implies the potential to do work.

power

Electrical power is the rate at which electrical energy is converted to another form, such as motion, heat, or an electromagnetic field. The common symbol for power is the uppercase letter P. The standard unit is the watt, symbolized by W. In utility circuits, the kilowatt (kW) is often specified instead; 1 kW = 1000W.

Power in a direct current (DC) circuit is equal to the product of the voltage in volts and the current in amperes. This rule also holds for low-frequency

alternating current (AC) circuits in which energy is neither stored nor released. At high AC frequencies, in which energy is stored and released (as well as dissipated or converted), the expression for power is more complex.

In a DC circuit, a source of V volts, delivering I amperes, produces P watts according to the formula: $P = VI$

When a current of I amperes passes through a resistance of R ohms, then the power in watts dissipated or converted by that component is given by: $P = I^2R$

When a potential difference of V volts appears across a component having a resistance of R ohms, then the power in watts dissipated or converted by that component is given by: $P = V^2/R$

power factor

In an AC, circuit loads other than resistance shift the phase angle between the voltage and the current. This shift is the result of energy being stored and released in inductors and capacitors. Since this storage does not represent a consumption of power, a power measurement must take the relative phase of voltage and current into account. The ratio of actual power to the simple product of measured voltage and measured current is called the power factor. Modern electronic devices such as microwave ovens, battery chargers, and computers do not draw current in the same sinusoidal wave shape as the incoming voltage. These distorted wave shapes are also less effective at delivering power and give rise to a power factor less than unity because of the additional frequencies present in the current waveform.

propagation

The transmission of an electrical or electromagnetic signal through a medium such as air or a conductor.

Q, R

RCBO or RCCB

Residual Current Circuit Breaker is a circuit breaker that includes an overcurrent trip mechanism like a conventional breaker and includes a leakage current trip that responds to current returning through a ground path instead of the neutral conductor or the other wires of a circuit with multiple live lines. The principle is the same as a Ground Fault Circuit Interrupter but RCCB's typically have a ground fault limit of 30mA or 100mA instead of 6mA of a GFCI used for personnel protection. GFCI's are generally useful for protecting a single load or a single branch circuit but are too sensitive for use as main circuit breakers. RCCB's are used for main circuit protection in Europe for boats, houses and commercial power distribution. Without this additional protection, as much as 40 Amps can flow in the ground wire, or into the water without tripping a conventional main circuit breaker.

RCD see also Residual Current Device

Recreational Craft Directive - European Directive 94/25-EC relating to recreational craft.

Following are special definitions related to the RCD:

CD

Committee Draft – the first draft circulated for comment by ISO Small Craft Technical Committee Working Group developing the standard.

CEN

The European Committee for Standardization.

DIS

Draft International Standard – an advanced draft where comments on the CD have been taken into account. Minor comments accepted by the Working Group will be incorporated in the FDIS, major changes will result in a second circulation as a DIS.

EN

European Standard (Norme).

FDIS

Final Draft International Standard – the last voting stage where standard bodies can only vote “yes” or “no” and the only changes will be editorial.

ICOMIA

The International Council of Marine Industry Associations – the International Marine Industry Trade Association, which represents 24 national marine industry associations. That includes virtually all countries with an active marine industry in Europe, North America, Asia and Australia. Its officers and members represent its members' views at the EU Commission, ISO, and CEN and its members' representatives are actively involved in all the RSG Standards Working Groups.

ISO

International Standards Organization

PREN

The abbreviation used by CEN to identify a draft standard at any stage.

WG

Working Group – the committee whose members have been nominated by their national standards body to develop any new standard required by the ISO Small Craft Tec. Committee (TC188) one of whom is chosen to act as the Convenor (Chairman/Secretary) by the TC188 members.

LIST OF EUROPEAN UNION (EU) & EUROPEAN ECONOMIC AREA (EEA) NATIONAL STANDARDS BODIES

Austria	ON	Italy	UNI
Belgium	IBN	Luxembourg	ITM
Denmark	DS	Netherlands	NNI
Finland	SFS	Norway*	NSF
France	AFNOR	Portugal	IPQ
Germany	DIN	Spain	AENOR
Greece	ELOT	Sweden	SIS
Iceland*	STRI	Switzerland	SNV
Ireland	NSIA	UK	BSI

* EEA countries – whose national standards bodies are participants in CEN debates, but have a non-voting status.

recognized (UL recognized)

A device that is UL Recognized differs from a device that is UL Listed. A Recognized device is expected to be installed within a larger assembly by a manufacturer, not in the field, and this larger assembly is then expected to be tested by UL. The UL Recognition then allows UL to skip testing of the specific embedded Recognized component. UL Recognition has little value for end users installing devices in the field.

rectifier

A device that allows current to flow in only one direction, such as a diode. Used to convert, or rectify AC current into DC.

regulator (voltage regulator)

A device, which uses a feedback loop to control the output of an alternator or other source. By measuring the output voltage and controlling the alternator field current, for example, the regulator is able to continuously adjust the alternator output to the desired voltage.

reserve capacity (battery)

RC is the number of minutes a new, fully charged battery at 80°F will sustain a discharge load of 25 amps to a cut-off voltage of 1.75 volts per cell (10.5V on 12V battery). This battery rating measures more of a continuous load on the battery.

residual current device

An RCD is an electrical safety device specially designed to immediately switch the electricity off when electricity is “leaking” to earth is detected at a level harmful to electrical equipment. In most countries using 50Hz power, an RCD is considered to provide personnel protection.

An RCD offers a high level of personal protection from electric shock when installed on a boat because the additional grounding through hull fittings is sufficient to trip and RCD during a fault. RCD's offer a backup level of safety if the green ground wire of a shore cable or a galvanic isolator has failed. Fuses or overcurrent circuit breakers do not offer the same level of personal protection against faults involving current flow to earth. RCDs are designed to operate within 10 to 50 milliseconds and to disconnect the electricity supply when they sense harmful leakage, typically 30 milliamps. See also GFI or GFCI devices which are similar in nature, but trip at 5mA for personnel protection. GFCI devices are required by ABYC standards for AC outlets in galleys, on deck and in machinery spaces. These cannot usually be used for the entire system because normal stray currents can cause nuisance tripping.

resistance

The opposition to the flow of current in an electric circuit as defined by Ohm's law. The unit of resistance is the ohm, symbol Ω , the Greek letter Omega.

reverse polarity

Describes a situation where the neutral and hot wires of an AC system are reversed. Most AC panels have an indicator to announce this condition, as it can be very dangerous.

RMS (Root-mean-square)

Root-mean-square (RMS) refers to the most common mathematical method of defining the effective voltage or current of an AC sine wave.

To determine RMS value, three mathematical operations are carried out on the function representing the AC waveform:

- (1) The square of the waveform function (usually a sine wave) is determined.
- (2) The function resulting from step (1) is averaged over time.
- (3) The square root of the function resulting from step (2) is found.

In a circuit whose impedance consists of a pure resistance, the RMS value of an AC wave is often called the effective value or DC-equivalent value. For example, if an AC source of 100 volts RMS is connected across a resistor, and the resulting current causes 50 watts of heat to be dissipated by the resistor, then 50 watts of heat will also be dissipated if a 100-volt DC source is connected to the resistor.

For a sine wave, the RMS value is 0.707 times the peak value, or 0.354 times the peak-to-peak value. Household utility voltages are expressed in RMS terms. A so-called “117-volt” AC circuit has a voltage of about 165 volts peak (pk), or 330 volts peak-to-peak (pk-pk).

S

SAE (Society of Automotive Engineers)

An organization which sets standards for various equipment used in the automotive industry. Since much of the basic equipment used in the marine industry originates in the automotive industry it can be a relevant specifications body for the marine industry as well.

SAE wire gauge

Wire sizes as specified by the SAE, specifically for stranded wire, similar to the AWG, see also AWG. The same gauge in SAE wire has a smaller conductor than in AWG wire.

sacrificial anode

A less noble metal intentionally connected to form a galvanic cell with a more noble metal for the purpose of protecting the more noble metal from corrosion. Most commonly zinc.

safety green (ground) wire

The non-current carrying conductor in a three wire 120V or four wire 240V AC circuit, it provides a safe path for fault current. See also green ground wire.

sealed lead-acid

see *Gel Cell self-limiting*

A device whose ability to limit output power regardless of input power is intrinsic to its design.

sheath

A material used as a continuous protective covering around one or more insulated conductors. The ABYC uses this term when discussing the allowable length of a conductor before it must have over current protection. The distance is extended if it is in a sheath.

shore power

AC utility power that is available when plugged into an outlet that is supplied from the main utility system.

short circuit

A conductive path of zero resistance. Typically refers to an unintentional connection between two conductors of opposite polarity. If a voltage is applied to a short circuit the current becomes very large and can start a fire, thus the need for short circuit, or overcurrent, protection in the form of fuses or circuit breakers.

shunt

A shunt resistor is a precise, low Ohm resistor that is temperature stable. It is used as a current "sensor" by using a millivolt meter to measure the voltage drop across it. Large current shunts are commonly made of one or more strips of manganin, a copper alloy capable of carrying high currents, that are soldered between machined blocks of brass with connecting bolts.

Shunts are rated according to the number of Amps they are capable of carrying and the voltage which is generated across the shunt when the rated current is being passed through it. Common shunt ratings include 100A 100mV or 500A 50mV. The resistance can be calculated by using Ohms Law, $V=IR$, $50mV=500A(R)$, therefore $R=0.1m\Omega$, or 0.0001Ω . This is a very small value of resistance; it must be in order to minimize the power loss when large currents are flowing.

The shunt normally has two separate screws with which the sense leads are attached. It is important to realize that the integrity of these connections are critical to accurate measurement and should not be used as current carrying connections.

sine wave

A waveform that can be expressed as the graph of the equation $y = \sin x$. The utility AC power is a sine wave.

single phase

The typical 120/240V AC system in the United States is a single phase system, meaning that the current flow in the two conductors is in phase or that they both cross zero at the same time.

skin effect

Skin effect refers to the phenomena of conductors' propagating AC current more efficiently on the conductors' surface than in its interior.

slow, slow blow see also *Delay*

A fuse that is a slow blow has a longer delay when subjected to over-current, before it fails. Slow blow fuses are required for loads that have high starting surges, like motors.

solenoid (relay)

An electromechanical device that is used to switch large currents. It consists of a coil of wire and a moving contact that makes an electrical connection when the coil of wire is energized.

source isolation (AC)

The arrangement of multiple AC power sources in such a manner that two AC sources cannot be connected to the same circuit simultaneously.

source selector

A switch or breaker configuration, which allows the user to pick which source to have connected to the bus. Typically used in AC systems with multiple sources such as shore power and one or more generators.

speed see *Delay*

Indicates how fast circuit protection devices react, specifically with respect to over circuit breakers and fuses.

square wave

An electrical waveform in which the current quickly goes from zero to its peak value in a step fashion. This is typical of inexpensive inverters.

starting bank

An arrangement of batteries that is designated for the function of engine starting.

storage battery

An electrochemical device capable of storing energy and releasing it and then able to be re-charged and repeat the process.

stray current

Unwanted current flows which occur due to a partial short circuit.

stray current corrosion

Corrosion that results when current from a battery or other external electrical (DC) source causes a metal in contact with an electrolyte to become anodic with respect to another metal in contact with the same electrolyte.

sulfation

Sulfation is the formation or deposit of lead sulfate on the surface and in the pores of the active material of the batteries' lead plates. If the sulfation becomes excessive and forms large crystals on the plates, the battery will not operate efficiently and may not work at all. Common causes of battery sulfation are standing a long time in a discharged condition, operating at excessive temperatures, and prolonged under or over charging.

surge

A large amount of current during the initial starting phase of a motor for example.

surge capacity

The measurement of the ability to withstand surge currents without damage.

surge current see also *Continuous Current*

The pulse of current that is associated with the initial large current required to start an electric motor, large resistive loads, and engine cranking.

switch

An electro-mechanical device that is intended to open an electrical circuit and thus turn a load or source on or off.

switchboard

see *Panelboard*

T

terminal

A connection point or device for an electrical circuit. A terminal strip is a series of screws which may or may not be connected to which wires are connected. Also refers to the connecting device which may be crimped on the end of a wire to enable it to be connected to the circuit with a screw, such as a ring terminal.

terminal studs

A threaded bolt onto which ring terminals may be placed and then fastened with a nut. Normally used for high current connections.

thermal

In a marine context thermal most commonly refers to a thermal circuit breaker, which uses the thermal effect of excess current flow to create differential expansion in a bi-metallic blade to open a circuit.

time-current curve see also *Delay*

A curve which depicts the relationship between the amount of current a fuse or breaker can hold with respect to time before opening the circuit.

tin plating

A plating of the element tin, which prevents corrosion. Commonly used to plate copper components such as a power bus.

toggle see also *Pole*

A switch which has a handle type actuator that can be placed in, at the most, three positions.

transfer switch, AC

see *source selector, Source Isolation*

An electrical relay or manual switch which selects an AC source alternative, such as a generator, shore power, or inverter.

transformer

see *Isolation Transformer*

trip free

A circuit breaker designed to trip when subjected to a fault current, even if the reset lever is held in the ON position.

U, V

ungrounded conductor

Any conductor that is not connected to the Earth ground system

volt (voltage)

The unit of electric potential and electromotive force, equal to the difference of electric potential between two points on a conducting wire carrying a constant current of one ampere when the power dissipated between the points is one watt.

volt-amps

The product of volts and amps, which is watts in a DC system and the apparent power in an AC system.

voltage drop

see *line loss*

W

watt

The unit of power which for a DC circuit is equal to volts times amps.

weatherproof

Constructed or protected so that exposure to the weather will not interfere with successful operation in rain, spray, and splash.

wire amperage rating

The current a conductor can carry under a set of specified conditions such as open air, in an enclosure, and at a specified temperature.

wire sizing

The process of selecting the appropriate sized conductor for the amount of current to be carried while considering the length of the circuit.

withstand voltage

The maximum voltage level that can be applied between circuits or components without causing insulation breakdown.

X, Y, Z

PN	PAGE	PN	PAGE	PN	PAGE	PN	PAGE	PN	PAGE	PN	PAGE
1001	116	2812	113	3401	47	3565	80, 81	4137	40	5120	37
1002	116	2904	113	3402	47	3566	79	4138	54	5121	37
1003	116	2908	113	3403	46, 47	3567	79	4140	86	5122	35-36
2001	115	2912	113	3405	80, 81	3568	78, 79	4150	54	5123	35-36
2002	115	3000	16-17	3406	80, 81	3569	78, 79	4151	54	5124	35-36
2003	115	3001	16-17	3407	80, 81	3570	80, 81	4152	54	5125	35-36
2010	115	3002	16-17	3408	84, 85	3571	80, 81	4153	54	5126	35-36
2011	115	3003	16-17	3409	80, 81	3572	80, 81	4154	54	5127	35-36
2101	115	3023	47	3411	82, 83	3573	78, 79	4155	54	5128	35-36
2102	115	3025	47	3412	80, 81	3574	79	4215	89	5129	35-36
2103	115	3027	80, 81	3458	78, 79	3575	78, 79	4216	89	5130	35-36
2104	110	3029	80, 81	3459	78, 79	3576	78, 79	4217	89	5131	35-36
2105	109	3032	67, 79	3460	82, 83	3577	78, 79	4218	89	5132	35-36
2106	109	3043	80, 81	3461	82, 83	3578	82, 83	4302	50, 51	5133	35-36
2107	110	3058	82, 83	3462	78, 79	3579	82, 83	4304	50, 51	5134	36
2201	114	3059	82, 83	3463	80, 81	3580	82, 83	4306	50, 51	5135	36
2202	114	3061	67, 79	3464	80, 81	3581	82, 83	4308	50, 51	5136	36
2203	114	3068	46, 47	3465	80, 81	3582	82, 83	4312	50, 51	5137	36
2204	114	3074	80, 81	3466	79	3583	82, 83	4314	50, 51	5138	58
2205	114	3076	80, 81	3467	79	3584	82, 83	4316	50, 51	5139	58
2206	114	3077	66, 80, 81	3468	78, 79	3585	80, 81	4318	50, 51	5140	58
2207	114	3079	66, 80, 81	3469	78, 79	3586	80, 81	4374	48, 49	5141	58
2208	114	3081	47	3470	80, 81	3587	80, 81	4376	48, 49	5142	58
2300	108	3082	47	3471	80, 81	3588	80, 81	4384	48, 49	5143	58
2301	106, 108	3084	84, 85	3472	80, 81	3589	79	4386	48, 49	5161	36
2302	108	3085	84, 85	3473	78, 79	3594	78, 79	5000	34	5162	36
2303	108	3086	84, 85	3474	79	3595	67, 79	5001	34	5163	36
2304	106	3095	84, 85	3475	78, 79	3596	78, 79	5002	37	5164	35-36
2305	106	3096	47	3476	78, 79	3598	67, 78, 79	5003	36	5165	35-36
2306	106	3097	82, 83	3477	78, 79	3599	78, 79	5004	35	5200	59
2402	111	3099	80, 81	3478	82, 83	4001	117	5005	35	5201	59
2404	111	3127	80, 81	3479	82, 83	4005	117	5006	58	5202	59
2406	111	3129	80, 81	3480	82, 83	4006	117	5007	37	5203	59
2408	111	3132	67, 79	3481	82, 83	4008	117	5015	56	5204	59
2410	111	3143	80, 81	3482	82, 83	4009	117	5018	56	5205	59
2502	111	3158	82, 83	3483	82, 83	4010	117	5021	54, 87	5206	59
2504	111	3159	82, 83	3484	82, 83	4011	117	5025	57	5207	59
2506	111	3161	67, 79	3485	80, 81	4012	117	5026	57	5208	59
2508	111	3165	82, 83	3486	80, 81	4013	117	5028	57	5209	59
2510	111	3174	80, 81	3487	80, 81	4014	117	5029	57	5210	59
2512	111	3176	80, 81	3488	80, 81	4015	117	5030	57	5211	59
2602	112	3177	66, 80, 81	3489	79	4016	117	5031	57	5212	59
2604	112	3179	66, 80, 81	3494	78, 79	4017	117	5033	57	5213	59
2606	112	3184	84, 85	3495	67, 79	4021	118	5034	57	5214	59
2608	112	3185	84, 85	3496	78, 79	4022	118	5101	34	5215	59
2610	112	3186	84, 85	3498	67, 78, 79	4023	118	5102	34	5216	59
2701	107	3195	84, 85	3499	78, 79	4026	88	5103	34	5217	59
2702	107	3197	82, 83	3505	80, 81	4027	88	5104	34	5218	59
2707	108	3199	80, 81	3506	80, 81	4028	88	5105	34	5219	59
2708	110	3264	46, 47	3507	80, 81	4029	88	5106	34	5220	59
2709	107	3265	82, 83	3508	84, 85	4031	88	5107	34	5221	59
2710	107	3375	46, 47	3509	80, 81	4100	88	5108	34	5222	59
2711	109	3376	47	3511	82, 83	4110	33, 64, 73	5112	37	5223	59
2714	106	3377	46, 47	3512	80, 81	4111	86	5113	37	5224	59
2715	108	3378	46, 47	3559	78, 79	4125	88	5114	37	5225	59
2720	107	3379	46, 47	3560	82, 83	4126	88	5115	37	5226	59
2722	107	3380	47	3561	82, 83	4130	88	5116	37	5227	59
2723	107	3381	46, 47	3562	78, 79	4131	88	5117	37	5228	59
2804	113	3382	46, 47	3563	80, 81	4135	40	5118	37	5229	59
2808	113	3385	47	3564	80, 81	4136	40	5119	37	5230	59

PN	PAGE	PN	PAGE	PN	PAGE	PN	PAGE	PN	PAGE	PN	PAGE
5231	59	7055	40	7230	41, 63, 72	7348	63, 72	8028	101	8177	66, 80, 81
5232	59	7056	40	7232	63, 72	7349	63, 72	8029	80, 81	8179	66, 80, 81
5233	59	7057	40	7233	63, 72	7350	32, 74	8030	90	8184	84, 85
5234	59	7058	40	7234	63, 72	7351	32, 74	8031	90	8185	84, 85
5235	59	7059	40	7235	63, 72	7352	32, 74	8032	67, 79	8186	84, 85
5236	59	7060	40	7236	63, 72	7353	32, 74	8033	87	8195	84, 85
5237	59	7061	40	7237	63, 72	7354	32, 74	8034	87	8197	82, 83
5238	59	7100	30	7238	63, 72	7355	32, 74	8035	86	8199	80, 81
5239	59	7102	30	7239	63, 72	7365	65, 74	8037	86	8200	86
5240	59	7104	30	7240	63, 72	7370	77	8038	101	8204	86
5241	59	7105	30	7241	63, 72	7371	77	8039	90	8205	86
5242	59	7106	30	7242	63, 72	7372	77	8041	101	8206	86
5243	59	7107	30	7244	32, 74	7373	77	8043	80, 81	8207	86
5244	59	7108	30	7246	32, 74	7374	77	8051	102	8208	86, 105
5245	59	7109	30	7248	32, 74	7374	77	8053	53	8209	86
5246	59	7110	30	7250	32, 74	7400	43, 73	8054	53	8210	86
5301	22	7111	30	7250I	32	7401	43, 73	8058	82, 83	8211	86
5302	22	7112	30	7251	65, 74	7402	43, 73	8059	82, 83	8212	86
5510e	14-15	7113	30	7254	65, 74	7403	43, 73	8061	67, 79	8214	90
5511e	14-15	7114	30	7256	65, 74	7404	43, 73	8065	87	8216	105
6005	12-13	7115	30	7258	65, 74	7405	43, 73	8066	87	8217	90
6006	12-13	7135	31	7260	63, 72	7406	43, 73	8067	90	8218	55
6007	12-13	7136	31	7262	32	7407	43, 73	8068	46, 47	8219	55
6010	12-13	7137	31	7263	32	7408	43, 73	8069	87	8220	55
6011	12-13	7138	31	7264	32	7425	43, 73	8072	87	8221	55
6337	69	7139	31	7265	32	7426	43, 73	8073	103	8222	55
6575	89	7140	31	7266	32	7427	43, 73	8074	80, 81	8230	22, 23, 55
7000	30	7141	31	7267	32	7428	43, 73	8076	80, 81	8231	55
7002	30	7142	31	7268	32	7429	43, 73	8077	66, 80, 81	8232	24, 25, 55
7004	30	7143	31	7269	32	7430	43, 73	8079	66, 80, 81	8233	55
7005	30	7144	31	7270	32	7431	43, 73	8080	19	8234	55
7006	30	7145	31	7271	32	7432	43, 73	8081	47	8235	98, 99
7007	30	7146	31	7287	65, 74	7433	43, 73	8082	47	8236	99
7008	30	7147	31	7288	65, 74	7450	33	8084	84, 85	8237	97
7009	30	7148	31	7289	65, 74	7451	33	8085	84, 85	8238	96, 97
7010	30	7198	30	7290	65, 74	7452	33	8086	84, 85	8239	96, 97
7011	30	7199	30	7291	41	7475	33	8087	33, 65	8240	101
7012	30	7200	41, 63, 72	7292	41	7476	33	8088	33, 65	8242	103
7013	30	7201	41, 63, 72	7293	41	7477	33	8089	33, 65	8243	101
7014	30	7202	41, 63, 72	7294	63, 72	7501	104	8095	84, 85	8244	100
7015	30	7204	41, 63, 72	7295	63, 72	7502	104	8096	47	8245	100
7035	31	7205	41, 63, 72	7299	41, 63, 72	7503	104	8097	82, 83	8246	100
7036	31	7206	41, 63, 72	7300	43, 64, 73	7505	104	8099	80, 81	8247	96, 97
7037	31	7208	41, 63, 72	7301	43, 64, 73	7600	24, 26	8127	80, 81	8248	98, 99
7038	31	7209	41, 63, 72	7302	43, 64, 73	7900	13	8129	80, 81	8250	101
7039	31	7210	41, 63, 72	7303	43, 64, 73	7901	13	8132	67, 79	8251	98, 99
7040	31	7212	41, 63, 72	7304	43, 64, 73	7902	13, 15, 17	8134	87	8252	101
7041	31	7213	41, 63, 72	7305	43, 64, 73	8003	101	8143	80, 81	8253	101
7042	31	7214	41, 63, 72	7306	43, 64, 73	8005	101	8158	82, 83	8254	101
7043	31	7216	41, 63, 72	7307	43, 64, 73	8013	102	8159	82, 83	8255	103
7044	31	7217	41, 63, 72	7308	43, 64, 73	8014	102	8161	67, 79	8256	103
7045	31	7218	41, 63, 72	7320	64, 73	8015	102	8165	82, 83	8257	103
7046	31	7220	41, 63, 72	7321	64, 73	8016	101	8166	87	8258	100
7047	31	7221	41, 63, 72	7322	64, 73	8017	101	8167	87	8259	55
7048	31	7222	41, 63, 72	7323	64, 73	8018	101	8169	87	8260	55
7050	40	7224	41, 63, 72	7324	64, 73	8019	101	8171	87	8261	53
7051	40	7225	41, 63, 72	7325	64, 73	8022	101	8172	87	8262	53
7052	40	7226	41, 63, 72	7326	64, 73	8023	47	8173	87	8263	53
7053	40	7228	41, 63, 72	7327	64, 73	8025	47	8174	80, 81	8264	46, 47
7054	40	7229	41, 63, 72	7347	41, 63, 72	8027	80, 81	8176	80, 81	8265	82, 83

PN	PAGE	PN	PAGE	PN	PAGE	PN	PAGE
8266	55	8407	80, 81	8569	78, 79	9003C	14-15
8267	55	8408	84, 85	8570	80, 81	9004C	14-15
8268	55	8409	80, 81	8571	80, 81	9009	68
8270	24, 25	8410	97, 102	8572	80, 81	9010	70
8271	52	8411	82, 83	8573	78, 79	9011	68
8272	52	8412	80, 81	8574	79	9012	23
8273	52	8458	78, 79	8575	78, 79	9019	69
8274	52	8459	78, 79	8576	78, 79	9030	117
8275	55	8460	82, 83	8577	78, 79	9031	117
8278	55	8461	82, 83	8578	82, 83	9038	117
8280	18	8462	78, 79	8579	82, 83	9039	117
8282	55	8463	80, 81	8580	82, 83	9040	117
8283	55	8464	80, 81	8581	82, 83	9041	117
8284	55	8465	80, 81	8582	82, 83	9077	70
8285	55	8466	79	8583	82, 83	9093	69
8286	55	8467	79	8584	82, 83	9001E	14-15
8287	55	8468	78, 79	8585	80, 81	9002E	14-15
8288	55	8469	78, 79	8586	80, 81	9003E	14-15
8289	55	8470	80, 81	8587	80, 81	9004E	14-15
8290	55	8471	80, 81	8588	80, 81	9112	25-26
8291	105	8472	80, 81	8589	79	9174	117
8292	55	8473	78, 79	8594	78, 79	9175	117
8293	55	8474	78, 79	8595	67, 79	9176	117
8294	55	8475	78, 79	8596	78, 79	9177	117
8295	55	8476	79	8598	67, 78, 79	9216	112
8296	55	8477	78, 79	8599	78, 79	9217	112
8297	55	8478	82, 83	8600	67	9218	112
8298	55	8479	82, 83	8602	67	9228	103
8299	55	8480	82, 83	8604	66, 76	9229	103
8357	68	8481	82, 83	8605	66, 76	9230	103
8358	70	8482	82, 83	8606	66, 76	9231	103
8359	68	8483	82, 83	8607	66, 76	9233	103
8361	70	8484	82, 83	8610	76	9353	100
8363	69	8485	80, 81	8611	76	9354	100
8365	68	8486	80, 81	8612	76	9630	100
8366	70	8487	80, 81	8613	76		
8367	68	8488	80, 81	8614	76		
8369	69	8489	79	8615	76		
8370	18	8494	78, 79	8616	76		
8371	52	8495	67, 79	8617	76		
8372	52	8496	78, 79	8618	76		
8373	52	8498	67, 78, 79	8619	76		
8374	52	8499	78, 79	8620	76		
8375	46, 47	8505	80, 81	8621	76		
8376	47	8506	80, 81	8675	45		
8377	46, 47	8507	80, 81	8676	45		
8378	46, 47	8508	84, 85	8677	45		
8379	46, 47	8509	80, 81	8678	45		
8380	47	8511	82, 83	8679	45		
8381	46, 47	8512	80, 81	8680	45		
8382	46, 47	8559	78, 79	8684	84, 85		
8383	87	8560	82, 83	8685	84, 85		
8384	87	8561	82, 83	8686	20		
8385	47	8562	78, 79	8687	20		
8386	69	8563	80, 81	8689	21		
8401	47	8564	80, 81	8690	20		
8402	47	8565	80, 81	8691	20		
8403	46, 47	8566	79	8693	21		
8405	80, 81	8567	79	9001C	14-15		
8406	80, 81	8568	78, 79	9002C	14-15		